

AEROSPACE & DEFENSE ISOLATOR CATALOG



Vibration, Shock & Motion Control Products

For Sensitive Equipment, Shipping Containers & Aircraft Interiors



DEALING WITH
VIBRATION AND **SHOCK**
IS A **FACT OF LIFE** IN THE
DESIGN AND **OPERATION**
OF **AVIATION** AND
DEFENSE
EQUIPMENT.



LORD CORPORATION
HAS SOLUTIONS FOR
AVIONICS, ELECTRONICS,
ACCESSORIES,
INTERIORS AND OTHER
AVIATION AND DEFENSE
APPLICATIONS.



TABLE OF CONTENTS

This catalog has been prepared to assist in the selection of LORD products to solve a variety of vibration and shock isolation problems in aerospace equipment. The theory applies to any problem in the field of vibration and shock isolation and many of the products shown in this catalog may be used for applications other than the protection of electronic equipment.

This catalog is intended to provide you with a basic background on vibration control theory and specific vibration and shock control solutions. This catalog features:

HISTORY 1-2

LORD CAPABILITIES / WHY LORD 3-5

VIBRATION & SHOCK THEORY 6-53

Terms & Definitions	7
Symbols	9
Considerations in Selecting a Vibration Isolator	12
Theory of Vibration/Shock Isolators	14
Shipping Container Isolator Selection	36

VIBRATION ISOLATION SOLUTIONS 54-122

LOW PROFILE AVIONICS MOUNTS

54

AM Series

MINIATURE MOUNTS

66

MAA Series | MGN/MGS Series | MCB Series

MICRO-MOUNTS™

80

MX Series

PLATE FORM MOUNTS

84

100 Series | 150 Series

MULTIPLANE MOUNTS

90

106 Series | 156 Series

BTR® BROAD TEMPERATURE RANGE MOUNTS

96

HT Series

PEDESTAL MOUNTS

102

PS Series

HIGH DEFLECTION MOUNTS

106

HDM Series | MHDM Series

SHIPPING CONTAINER MOUNTS

110

J-18100 Series

INTERIOR ISOLATORS

116

Sidewall Panel | Floor Panel | Close-Out Panel |
Rod Ends | Grommets

QUESTIONNAIRES 123-127

Engineering Data for Vibration and Shock Isolator	123
Shipping Container Suspension System	125

LORD[®]

BONDED RUBBER



Support OUR Troops!



BUY
WAR BONDS!

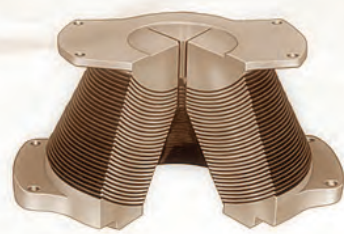
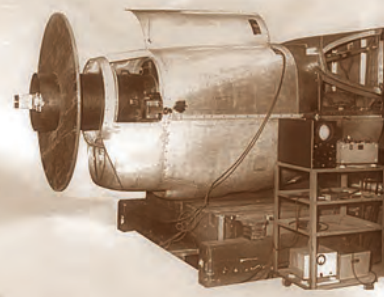
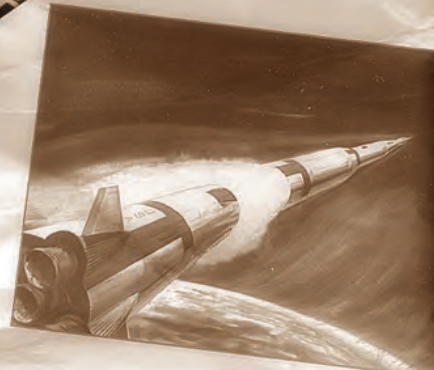

HISTORY

1920s

- When Hugh Lord, a patent attorney in Erie, Pennsylvania, cannot find others to satisfactorily make any of his 15 inventions, he hires six employees and forms LORD Manufacturing Company.
- LORD is adopted as a registered trademark.

1930s

- LORD mountings for instrument panels are used by Charles & Anne Lindbergh on their historic flight to China.
- LORD instrument panel mounts lengthen service life of instruments by 100-fold and become popular with many airplane manufacturers.
- Dynafocal engine suspensions are developed from a licensed patent which originated at Massachusetts Institute of Technology. LORD makes multiple row radial engines practical with this innovation.

1940s

- To support U.S. Forces in World War II, LORD devotes all production to mountings for aircraft engines, radios and instrumentation. LORD is exclusive supplier of engine mounts to virtually all aircraft manufacturers.
- LORD begins transition from military to commercial economy. Mountings for railroad cars and buses are developed and manufactured. LORD designs and produces the first elastomeric parts – transmission and engine isolators for the Bell Model 47 helicopter. Tom Lord is named President.
- LORD develops and manufactures a new design of multiplane mountings used on aircraft instrument panels. These mountings later become the standard on all aircraft.

1950s

- The Korean War begins in June creating an increased need for aircraft engine mounts. “Special Purpose Elastomers” (SPE[®]) are developed as substitutes for natural rubber.
- LORD develops Broad Temperature Range elastomer for use in BTR[®] (-65 to +300°F) Mountings. These replace traditional rubber mounts and metal friction-damped assemblies and serve aerospace industries into the 21st Century.

1960s

- LORD manufactures the world’s first production elastomeric bearing for Bell Helicopter. The gimbal ring mount for gyros and internal platforms is developed for NASA’s Lunar Rover.

1970s

- LORD and Bell Helicopter jointly design the elastomeric elements for the nodal beam pylon isolation system.
- High Capacity Laminate (HCL) bearings gain acceptance in the helicopter industry. They weigh less than conventional bearings, require no lubrication and prove more reliable and easier to maintain.

1980s

- LORD begins design and qualification of elastomeric bearings for the Navy V-22 tilt-rotor aircraft.

1990s

- LORD and Mil Helicopter (Moscow) sign a partnership agreement for purchase of elastomeric bearings, dampers and isolators for use on Russian helicopters and fixed wing aircraft.
- NVX noise cancellation systems are used to quiet cabins in business jets.
- LORD receives Helicopter Society’s first prestigious “Supplier of the Year” award for many technical contributions to the helicopter industry worldwide.

2000s

- Company receives numerous Supplier Awards. Ground is broken on a \$3.8 million expansion project to the Dayton, Ohio facility to meet customer aerospace market demand.
- Boeing 787 and JSF F-35 complete first flight. Both have LORD solutions utilizing a wide array of unprecedented technologies to solve challenging vibration environments.

LORD CAPABILITIES

PROVIDING SOLUTIONS THROUGH INNOVATION

Sometimes the greatest innovations come when solutions that have become standard practice in one industry are used to solve problems in other industries. Such is the case for LORD Corporation's technologies and solutions that can be applied to challenges in the aerospace industry. Building on more than 80 years of innovation, LORD provides valuable expertise in active and passive vibration, motion and shock control. We are continually called upon by the wind, transportation, construction, manufacturing, electronics and U.S. defense industries to solve their toughest problems around the world. Save time and expense by collaborating with us to achieve your goals ... Ask Us How.

Active Vibration Control Systems (AVCS):

LORD AVCS are being used to minimize vibration and remove weight in helicopters and business jets.



Structural Bonding Adhesives:

LORD® Structural Adhesives are a durable and attractive fastening solution to replace welds, rivets, screws, tapes and other traditional fastening methods.



Advanced Elastomeric Systems:

LORD offers a wide range of elastomeric systems tuned to achieve useful dynamic effects, from accommodating helicopter rotor head motions to isolating vibrating machinery or airplane engines.



Magnelok™ Brakes:

Magnelok electromagnetic brakes achieve very high holding torques per unit of volume and weight.



Diagnostic Systems:

LORD diagnostic systems employ electronic hardware and software to monitor the health of rotating components.



Magneto-Rheological (MR) Solutions:

MR fluids reversibly and instantaneously change from a free-flowing liquid to a semi-solid, enabling controllable dampers, brakes and other devices requiring precise control of resistance.



In-Flight Propeller Balancing Systems:

LORD balancing systems correct propeller or fan imbalance in real time, continuously, as the equipment operates.



Ultra-Conductive Coatings and Adhesives:

LORD ultra-conductive materials provide previously unobtainable levels of conductivity and current-carrying capacity in film or paste epoxy materials.



WHY CHOOSE LORD?

WHY LORD

World Class Product Design

Our expertise goes beyond a technical solution and our greatest value comes when we can help design a complete system. A full complement of engineering tools, including a fully accredited test lab plus all major design and analysis software packages, ensure compatibility with you.

Analysis Tools (DynaSim6, etc.)

LORD has the unique ability to understand system responses with isolation, optimize the isolator solution and predict isolator life. Our ability to predict isolator life is unique to LORD.

Materials Performance

A true cornucopia of LORD proprietary elastomer blends, custom formulated for specific elastic, damping and environmental properties.

Elastomer Testing and Validation

Each and every LORD elastomer blend is statically and dynamically tested under a variety of frequencies and strains, prior to release to production, to ensure they meet the required elastic modulus and damping values. This testing is a quantum leap beyond what's required by ASTM Standards.

Part Testing and Validation

Samples from each lot of isolators made are dynamically tested to ensure repeatable performance, order after order.

Technical Engineering Support

LORD has a long history of providing strong Technical Support to Aerospace Customers, available at +1 877 ASK LORD (275 5673).

Experience

We stand on the shoulders of the giants who have gone before us here at LORD. This experience can be a game-changer for the customer when understanding and solving complex vibration and shock applications.

Trust

Our customers have come to trust LORD. Our willingness to tell the truth based on facts gives our customers a high level of confidence in our recommendations.

Training (Informal and Formal)

Our customers value our ability to reduce vibration and shock theory to practice. They learn from us and consider us an extension of their Engineering Department – members of their team. To request a training event hosted by LORD Corporation at your facility, please contact LORD at customer.support@lord.com

VIBRATION & SHOCK THEORY

VIBRATION & SHOCK THEORY

Before attempting to apply any isolator, it is important to know as much as possible about the conditions under which it will be used and the sensitivity (fragility) of the equipment to be mounted. This knowledge must be coupled with an understanding of the various types of vibration and shock isolators which might be applied to a given problem. Depending on the type of isolator, the material from which it is made and the operating conditions, the performance of the isolator and its effectiveness can vary widely. These factors must be considered, and the proper accommodations made to theory, to arrive at a reasonably accurate estimate of the performance of the isolated system.

The following discussion presents the basic theory and some trends of material performance in order to address the peculiarities of the real world of vibration and shock theory.



TERMS & DEFINITIONS

There are a number of terms which should be understood before entering into a discussion of vibration and shock theory. Some of these are quite basic and may be familiar to many of the users of this catalog. However, a common understanding should exist for maximum effectiveness.

Center-of-Gravity System — An equipment installation wherein the center of gravity of the equipment coincides with the elastic center of the isolation system.

Damping — The “mechanism” in an isolation system which dissipates energy. This mechanism controls resonant amplification (transmissibility).

Decibel - (dB) — A dimensionless expression of the ratio of two values of some variable in a vibratory system. For example, in random vibration the ratio of the power spectral density at two frequencies is given as:

$$dB = 10 \text{Log}_{10} \frac{S_{f_1}}{S_{f_2}}$$

Deflection — The movement of some component due to the imposition of a force. In vibratory systems, deflection may be due to static or dynamic forces or to the combination of static and dynamic forces.

Degree-of-Freedom — The expression of the amount of freedom a system has to move within the constraints of its application. Typical vibratory systems may move in six degrees of freedom — three translational and three rotational modes (motion along three mutually perpendicular axes and about those three axes).

Dynamic Matching — The selection of isolators whose dynamic characteristics (stiffness and damping) are very close to each other for use as a set on a given piece of equipment. Such a selection process is recommended for isolators which are to be used on motion sensitive equipment such as guidance systems, radars and optical units.

Dynamic Disturbance — The dynamic forces acting on the body in a vibratory system. These forces may be the results of sinusoidal vibration, random vibration or shock, for example.

Elastomer — A generic term used to include all types of “rubber” — natural or synthetic. Many vibration isolators are manufactured using some type of elastomer. The type depends on the environment in which the isolator is to be used.

Fragility — The amount of vibration or shock that a piece of equipment can take without malfunctioning or breaking. In isolation systems, this is a statement of the amount of dynamic excitation which the isolator can transmit to the isolated equipment.

Free Deflection — The amount of space an isolated unit has in which it can move without interfering with surrounding equipment or structure. This is sometimes called “sway space.”

“g” level — An expression of the vibration or shock acceleration level being imposed on a piece of equipment as a dimensionless factor times the acceleration due to gravity.

Isoelastic — A word meaning that an isolator, or isolation system, exhibits the same stiffness characteristics in all directions.

Isolation — The protection of equipment from vibration and/or shock. The degree (or percentage) of isolation necessary is a function of the fragility of the equipment.

VIBRATION & SHOCK THEORY

Linear (properties) — A description of the characteristics of an isolation system which assumes that there is no variation with deflection, temperature, vibration level, etc. This is a simplifying assumption which is useful for first approximations but which must be treated carefully when dealing with critical isolation systems.

Loss Factor — A property of an elastomer which is a measure of the amount of damping in the elastomer. The higher the loss factor, the higher the damping. Loss factor is typically given the Greek symbol “ η ”. An approximation may be made that loss factor is equal to the inverse of the resonant transmissibility of a vibratory system. The loss factor of an elastomer is sensitive to the loading and ambient conditions being imposed on the system.

Modulus — A property of elastomers (analogous to the same property of metals) which is the ratio of stress to strain in the elastomer at some loading condition. Unlike the modulus of metals, the modulus of elastomers is non-linear over a range of loading and ambient conditions. This fact makes the understanding of elastomers and their properties important in the understanding of the performance of elastomeric vibration and shock isolators.

Natural Frequency — That frequency (expressed in “Hertz” or “cycles per second”) at which a structure, or combination of structures, will oscillate if disturbed by some force (usually dynamic) and allowed to come to rest without any further outside influence. Vibratory systems have a number of natural frequencies depending on the direction of the force and the physical characteristics of the isolated equipment. The relationship of the system natural frequency to the frequency of the vibration or shock determines, in part, the amount of isolation (protection) which may be attained.

Octave — A doubling of frequency. This word is used in various expressions dealing with vibration isolation.

Power Spectral Density — An expression of the level of random vibration being experienced by the equipment to be isolated. The units of power spectral density are “ g^2/Hz ” and the typical symbol is “ S_f ”.

Random Vibration — Non-cyclic, non-sinusoidal vibration characterized by the excitation of a broad band of frequencies at random levels simultaneously. Typically, many applications of equipment in the field of Military Electronics are exposed to random vibration.

Resilience — The ability of a system to return to its initial position after being exposed to some external loading. More specifically, the ability of an isolator to completely return the energy imposed on it during vibration or shock. Typically, highly damped elastomers have low resilience while low-damped elastomers have good resilience.

Resonance — Another expression for natural frequency. A vibratory system is said to be operating in resonance when the frequency of the disturbance (vibration or shock) is coincident with the system natural frequency.

Resonant Dwell — A test in which the equipment is exposed to a long term vibration at its resonant frequency. This test was used as an accelerated fatigue test for sinusoidal vibration conditions. In recent times, sinusoidal testing is being replaced by random vibration testing and resonant dwell tests are becoming less common.

Returnability — The ability of a system, or isolator, to resume its original position after removal of all outside forces. This term is sometimes used interchangeably with resilience.

Roll-off Rate — The steepness of the transmissibility curve being recorded during a vibration test, after the system natural frequency has been passed. This term is also used to describe the slope of a random vibration curve. The units are typically “ $\frac{dB}{octave}$ ”

VIBRATION & SHOCK THEORY

SYMBOLS

Symbol	Description	Units
A	Load area (cross sectional area) of the elastomer	in ²
A _o	Response acceleration	multiples of g
b	Longitudinal horizontal distance from C.G. to mount (half mount spread)	inches
B ₁	Maximum vertical acceleration at C.G.	in/sec ²
B ₂	Maximum vertical acceleration at unit end due to rotation about E.C.	in/sec ²
c	Distance from E.C. to top of unit	inches
C	Damping coefficient	lb-sec/in
C.G.	Center of gravity of mounted equipment	--
C _C	Critical damping factor	lb-sec/in
dB	A logarithmic unit of sound intensity	--
D.A.	Double amplitude	--
d _M	Dynamic deflection at mount	inches
d	System deflection	inches
d _{Rstatic}	Static rotational deflection	rad
d _{shock}	Shock deflection	inches SA
d _{static}	Static deflection of the system	inches
d _T	Deflection total at end of unit	inches
d _{vib}	Deflection due to vibration	inches SA
e	Eccentricity, or distance between E.C. and C.G.	inches
E.C.	Elastic center of mounting system	--
f	Exciting vibration frequency	Hz
F	Force	lb
F _o	Maximum force output	lb
f _c	Coupled natural frequencies	Hz
f _n	Natural frequency, translational	Hz
f _{nd}	Natural frequency of damped system	Hz
f _{nn}	Nominal natural frequency	Hz
f _{shock}	Shock natural frequency	Hz
g _n	Number of g's being imposed	multiples of g
g	Acceleration due of gravity	386 in/sec ²
G	Elastomer shear modulus	psi
G*	Complex modulus	psi
G'	Dynamic modulus of the elastomer	psi
G' _n	Dynamic modulus at the particular vibration condition being analyzed	psi
G''	Damping (loss) modulus	psi
G _{CG}	G load at C.G.	multiples of g

VIBRATION & SHOCK THEORY

Symbol	Description	Units
g_i	Specified vibratory acceleration input	multiples of g
G_i	Input shock level	multiples of g
g_o	Vibratory response acceleration	multiples of g
G_o	Shock response or equipment fragility of unit at C.G.	multiples of g
g_{oRMS}	1 σ RMS acceleration response	multiples of g
$g_{o3\sigma}$	Response acceleration at 3 σ vibration level	multiples of g
G_T	Total vertical acceleration at end of container	multiples of g
h	Drop height	inches
h_1	Vertical distance of pivot point above floor	inches
I_{CG}	Moment of inertia about C.G.	lb-in-sec ²
I_P	Moment of inertia about container pivot point	lb-in-sec ²
k	Radius of gyration	inches
K	Static spring rate	lb/in
K'	Dynamic spring rate	lb/in
K'_S	Dynamic shear spring rate	lb/in
K'_{shock}	Shock dynamic spring rate	lb/in
K'_V	Dynamic vertical spring rate	lb/in
K_C	Compression spring rate	lb/in
KE	Kinetic energy	in-lb
K'_H	Dynamic horizontal spring rate	lb/in
K'_R	Dynamic torsional or rotation spring rate	in-lb/rad
K_S	Static shear spring rate	lb/in
K_V	Static vertical spring rate	lb/in
ℓ	Length of container, overall	inches
ℓ_1	Distance from C.G. to end of unit	inches
L	Ratio of compression stiffness to shear stiffness	--
M	Mass of equipment	lb-sec ² /in
n	Number of equally loaded mounts	--
P	Applied force	lb
p	Lateral horizontal distance from C.G. to mount (half mount spread)	inches
P_A	Actual load	lb
PE	Potential energy	in-lb
P_{max}	Maximum applied load	lb
P_R	Rated load	lb
r	Ratio of exciting frequency to system natural frequency	--
R	Distance from container pivot point to C.G.	inches
RMS	Root mean square	--

VIBRATION & SHOCK THEORY

Symbol	Description	Units
S	Square root of ratio of rotational spring rate to lateral translation spring rate	inches
S_f	Power spectral density	g^2/Hz
S_i	Input random vibration	g^2/Hz
S_o	Output random vibration	g^2/Hz
T	Transmissibility	--
t	Time	sec
T_{ABS}	Absolute transmissibility	--
t_n	One-half of the natural period of the system	sec
T_R	Resonant transmissibility	--
t_R	Elastomer thickness	inches
T_S	Shock transmissibility	--
V	Normal linear velocity of C.G. at impact	in/sec
V_1	Normal linear velocity of unit end due to rotation about C.G. at impact	in/sec
V_o	Impact velocity	in/sec
W	Weight of suspended mass	lb
x	Horizontal distance from container pivot point (p) to C.G.	inches
X_i	Vibratory input motion	inches DA
X_o	Vibratory response motion	inches DA
y	Vertical distance from container pivot point (p) to C.G.	inches
z	Length of suspended unit	inches
α	Angle between the compression axis and horizontal	degrees
β	Angle between the compression axis and vertical	degrees
ϵ	Strain	in/in
ζ	Damping ratio	--
η	Loss factor	--
θ_1	Angle between a line joining C.G. and pivot point (p) and vertical before drop (when $h = 0$)	degrees
θ_2	Angle between a line joining C.G. and pivot point (p) and vertical after drop (when $h = 0$)	degrees
σ	Dynamic stress	lb/in ²
τ	Shock input pulse duration	sec
Φ	$\tan^{-1}(x/y)$ angle between a line joining C.G. and pivot point (p) and horizontal	degrees
ω_0	Angular velocity at impact	rad/sec
ω_1	Translational circular frequency	rad/sec
ω_2	Rotational circular frequency	rad/sec

CONSIDERATIONS IN SELECTING A VIBRATION ISOLATOR

In the process of deciding on a vibration isolator for a particular application, there are a number of critical pieces of information which are necessary to define the desired functionality of the isolator. Some items are more critical than others but all should be considered in order to select or design the appropriate product.

Some of the factors which must be considered are:

Weight, Size, Center-of-Gravity of the Equipment to be Isolated — The weight of the unit will have a direct bearing on the type and size of the isolator. The size or shape of the equipment can also affect the isolator design since this may dictate the type of attachment and the available space for the isolator. The center-of-gravity location is also important as isolators of different load capacities may be necessary at different points on the equipment due to weight distribution. The locations of the isolators relative to the center-of-gravity — at the base of the equipment versus in the plane of the C.G., for example — could also affect the design of the isolator.

Types of Dynamic Disturbances to be Isolated — This is basic to the definition of the problem to be addressed by the isolator selection process. In order to make an educated selection or design of a vibration/shock isolator, this type of information must be defined as well as possible. Typically, sinusoidal and/or random vibration spectra will be defined for the application. In many installations of military electronics equipment, random vibration tests have become commonplace and primary military specifications for the testing of this type of equipment (such as MIL-STD-810) have placed heavy emphasis on random vibration, tailored to the actual application. Other equipment installations, such as in shipping containers, may require significant amounts of sinusoidal vibration testing.

Shock tests are often required by many types of equipment. Such tests are meant to simulate those operational (e.g., carrier landing of aircraft) or handling (e.g., bench handling or drop) conditions which lead to impact loading of the equipment.

Static Loadings Other than Supported Weight — In addition to the weight and dynamic loadings which isolators must react, there are some static loads which can impact the selection of the isolator. An example of such loading is the load imposed by an aircraft in a high speed turn. This maneuver loading must be reacted by the isolator and can, if severe enough, necessitate an increase in the isolator size. These loads are often superposed on the dynamic loads.

Allowable System Response — This is another basic piece of information. In order to appropriately isolate a piece of equipment, the response side of the problem must be known. The equipment manufacturer or user should have some knowledge of the fragility of the unit. This fragility, related to the specified dynamic loadings will allow the selection of an appropriate isolator. This may be expressed in terms of the vibration level versus frequency or the maximum shock loading which the equipment can endure without malfunctioning or breaking. If the equipment manufacturer or installer is experienced with vibration/shock isolation, this allowable response may be specified as the allowable natural frequency and maximum transmissibility allowed during a particular test.

The specification of allowable system response should include the maximum allowable motion of the isolated equipment. This is important to the selection of an isolator since it may define some mechanical motion limiting feature which must be incorporated into the isolator design. It is fairly common to have an incompatibility between the allowable “sway space” and the motion necessary for the isolator to perform the desired function. In order to isolate to a certain degree, it is required that a definite amount of motion be allowed. Problems in this area typically arise when isolators are not considered early enough in the process of designing the equipment or the structural location of the equipment.

Ambient Environment — The environment in which the equipment is to be used is very important to the selection of an isolator. Within the topic of environment, temperature is by far the most critical item. Variations in temperature can cause variations in the performance of many typical vibration/shock isolators. Thus, it is quite important to know the temperatures to which the system will be exposed. The majority of common isolators are elastomeric. Elastomers tend to stiffen and gain damping at low temperatures and to soften and lose damping at elevated temperatures. The amount of change depends on the type of elastomer selected for a particular installation.

VIBRATION & SHOCK THEORY

Other Environmental Effects — Effects from humidity, ozone, atmospheric pressure, altitude, etc. are minimal and may typically be ignored. Some external factors that may not be thought of as environmental may impact on the selection of an isolator. Fluids (oils, fuels, coolants, etc.) which may come in contact with the isolators can cause a change in the material selection or the addition of some form of protection for the isolators. The level of fluid exposure (immersion vs. splash) is a determining factor.

Service Life — The length of time for which an isolator is expected to function effectively is another strong determining factor in the selection or design process. Vibration isolators, like other engineering structures, have finite lives. Those lives depend on the loads imposed on them. The prediction of the life of a vibration/shock isolator depends on the distribution of loads over the typical operating spectrum of the equipment being isolated. Typically, the longer the desired life of the isolator, the larger that isolator must be for a given set of operating parameters. The definition of the isolator operating conditions is important to any reliable prediction of life.

Specification of Isolator Selection

Factors — This catalog includes a questionnaire, or “Data Required” form, which is helpful in the definition of the above areas of information. If the indicated information is available, the selection of an isolator will be greatly enhanced. The theory that follows in the next section is academic if the information to apply it is not available. If an equipment designer is attempting to select an isolator from this catalog, the job will be eased by having this information available. Likewise, if a company like LORD must be consulted for assistance in the selection or design of an isolator, then communications and accuracy of response will be improved by having such information ready.

THEORY OF VIBRATION/SHOCK ISOLATORS

The solutions to most isolator problems begin with consideration of the mounted system as a damped, single degree of freedom system. This allows simple calculations of most of the parameters necessary to decide if a standard isolator will perform satisfactorily or if a custom design is required.

This approach is based on the facts that:

1) Many isolation systems involve center-of-gravity installations of the equipment. That is, the center-of-gravity of the equipment coincides with the elastic center of the isolation system. The center-of-gravity installation is often recommended since it allows performance to be predicted more accurately and it allows the isolators to be loaded in an optimum manner. Figure 1 shows some typical center-of-gravity systems.

2) Many equipment isolation systems are required to be isoelastic. That is, the system translational spring rates in all directions are the same.

3) Many pieces of equipment are relatively light in weight and support structures are relatively rigid in comparison to the stiffness of the isolators used to support and protect the equipment.

For cases which do not fit the above conditions, or where more precise analysis is required, there are computer programs available to assist the analyst.

LORD computer programs for dynamic analysis are used to determine the system response to various dynamic disturbances. The loads, motions and accelerations at various points on the isolated equipment may be found and support structure stiffnesses may be taken into account. Some of the more sophisticated programs may even accept and analyze non-linear systems. This discussion is reason to emphasize the need for the information regarding the intended application of the isolated equipment. The dynamic environment, the ambient environment and the physical characteristics of the system are all important to a proper analysis. The use of the checklist included with this catalog is recommended as an aid.

With the above background in mind, the aim of this theory section will be to use the single degree-of-freedom basis for the initial selection of standard isolators. This is the first step toward the design of custom isolators and the more complex analyses of critical applications.

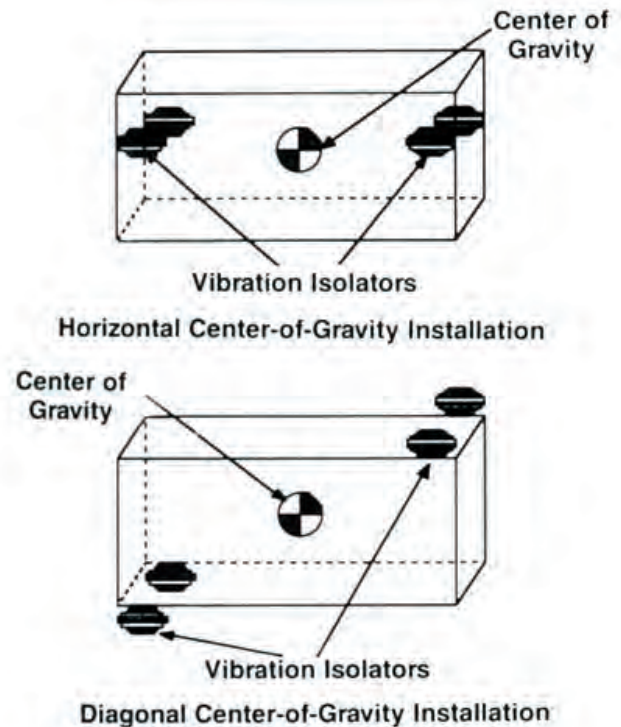

FIGURE 1 –
TYPICAL CENTER-OF-GRAVITY INSTALLATIONS

VIBRATION & SHOCK THEORY

SINGLE DEGREE-OF-FREEDOM DYNAMIC SYSTEM

Figure 2 shows the “classical” mass-spring-damper depiction of a single degree-of-freedom dynamic system. Figure 3 and the related equations show this system as either damped or undamped. Figure 4 shows the resulting vibration response transmissibility curves for the damped and undamped systems of Figure 3.

These figures and equations are well known and serve as a useful basis for beginning the analysis of an isolation problem. However, classical vibration theory is based on one assumption that requires understanding in the application of the theory. That assumption is that the properties of the elements of the system behave in a linear, constant manner. Data to be presented later will give an indication of the factors which must be considered when applying the analysis to the real world.

The equations of motion for the model systems in Figure 3 are familiar to many. For review purposes, they are presented here.

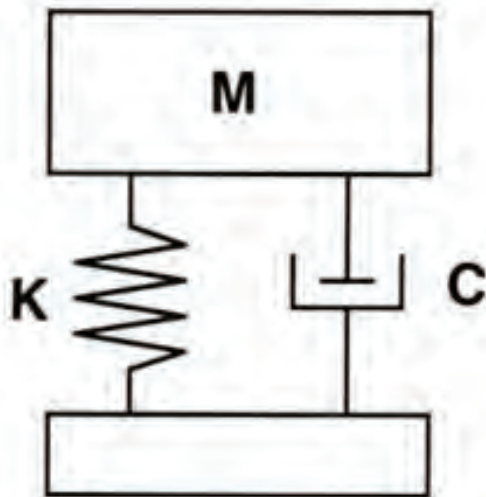

M = Mass – stores kinetic energy
K = Spring – stores potential energy, supports load
C = Damper – dissipates energy, cannot support load

FIGURE 2 – ELEMENTS OF A VIBRATORY SYSTEM

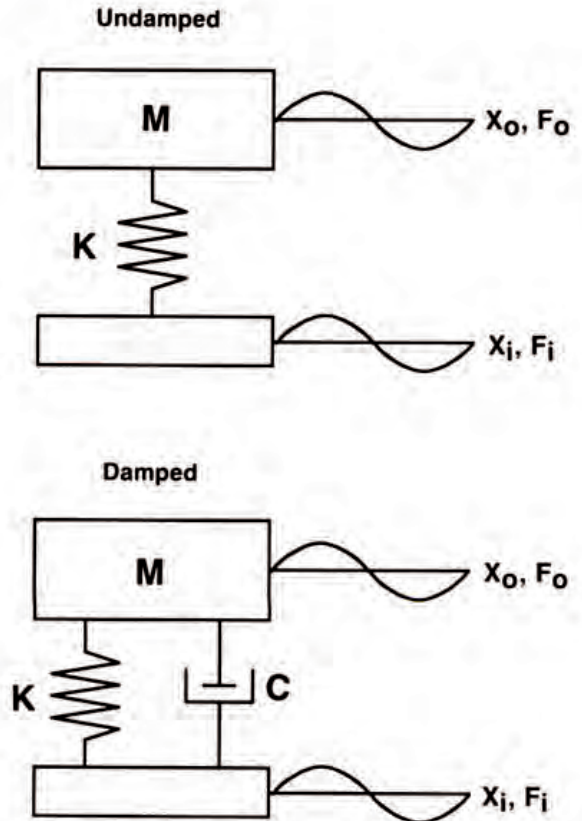

FIGURE 3 – DAMPED AND UNDAMPED SINGLE DEGREE-OF-FREEDOM BASE EXCITED VIBRATORY SYSTEMS

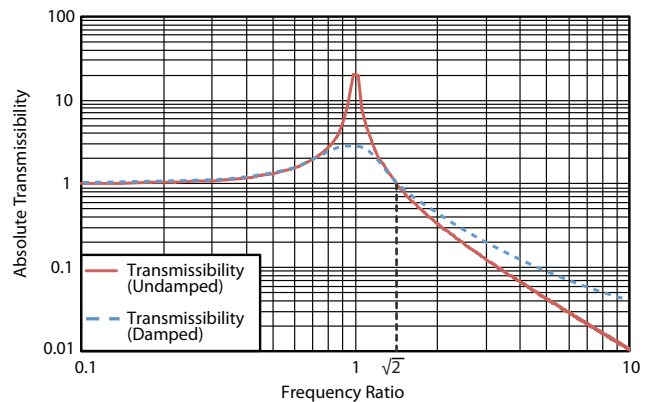

FIGURE 4 – TYPICAL TRANSMISSIBILITY CURVES

VIBRATION & SHOCK THEORY

For the undamped system, the differential equation of motion is:

$$M\ddot{X} + KX = F(t)$$

In which it may be seen that the forces due to the dynamic input (which varies as a function of time) are balanced by the inertial force of the accelerating mass and the spring force. From the solution of this equation, comes the equation defining the natural frequency of an undamped spring-mass system:

$$f_n = \frac{1}{2\pi} \sqrt{K/M}$$

Another equation which is derived from the solution of the basic equation of motion for the undamped vibratory system is that for transmissibility – the amount of vibration transmitted to the isolated equipment through the mounting system depending on the characteristics of the system and the vibration environment.

$$T_{ABS} = \frac{1}{(1 - r^2)}$$

Wherein, “r” is the ratio of the exciting vibration frequency to the system natural frequency. That is:

$$r = \frac{f}{f_n}$$

In a similar fashion, the damped system may be analyzed. The equation of motion here must take into account the damper which is added to the system. It is:

$$M\ddot{X} + C\dot{X} + KX = F(t)$$

The equation for the natural frequency of this system may, for normal amounts of damping, be considered the same as the undamped system. That is,

$$f_n = \frac{1}{2\pi} \sqrt{K/M}$$

In reality, the natural frequency does vary slightly with the amount of damping in the system. The damping factor is given the symbol “ ζ ” and is approximately one-half the loss factor, “ η ”, described in the definition section regarding damping in elastomers. The equation for the natural frequency of a damped system, as related to that for an undamped system, is:

$$f_{nd} = f_n \sqrt{1 - \zeta^2}$$

The damping ratio, ζ , is defined as:

$$\zeta = C / C_c$$

$$\zeta \approx \eta / 2$$

Where, the “critical” damping level for a damped vibratory system is defined as:

$$C_c = 2\sqrt{KM}$$

The equation for the absolute transmissibility of a damped system is written as:

$$T_{ABS} = \frac{\sqrt{1 + (2\zeta r)^2}}{\sqrt{(2\zeta r)^2 + (1 - r^2)^2}}$$

The equations for the transmissibilities of the undamped and damped systems are plotted in Figure 4. As may be seen, the addition of damping reduces the amount of transmitted vibration in the amplification zone, around the natural frequency of the system ($r = 1$). It must also be noted that the addition of damping reduces the amount of protection in the isolation region (where $r > \sqrt{2}$).

In the real world of practical isolation systems, the elements are not linear and the actual system response does not follow the above analysis rigorously. Typically, elastomeric isolators are chosen for most isolation schemes. Elastomers are sensitive to the vibration level, frequency and temperature to which they are exposed. The following discussion will present information regarding these sensitivities and will provide some guidance in the application of isolators for typical installations.

Elastomers for Vibration and Shock Isolation

Depending on the ambient conditions and loads, a number of elastomers may be chosen for the isolators in a given isolation system. As seen in the above discussion, the addition of damping allows more control of the system in the region of resonance. The compromise which is made here though is that isolation is sacrificed. The higher the amount of damping, the greater the compromise. In addition, typical highly damped elastomers exhibit poor returnability and greater drift than elastomers which have medium or low damping levels. The requirements of a given application must be carefully weighed in order to select the appropriate elastomer.

Within the various families of LORD products, a number of elastomers may be selected. Some brief descriptions may help to guide in their selection for a particular problem.

Natural Rubber — This elastomer is the baseline for comparison of most others. It was the first elastomer and has some desirable properties, but also has some limitations in many applications. Natural rubber has high strength, when compared to most synthetic elastomers. It has excellent fatigue properties and low to medium damping which translates into efficient vibration isolation. Typically, natural rubber is not very sensitive to vibration amplitude (strain). On the limitation side, natural rubber is restricted to a fairly narrow temperature range for its applications. Although it remains flexible at relatively low temperatures, it does stiffen significantly at temperatures below 0°F (-18°C). At the high temperature end, natural rubber is often restricted to use below approximately 180°F (82°C).

Neoprene — This elastomer was originally developed as a synthetic replacement for natural rubber and has nearly the same application range. Neoprene has more sensitivity to strain and temperature than comparable natural rubber compounds.

SPE® I — This is another synthetic elastomer which has been specially compounded by LORD for use in applications requiring strength near that of natural rubber, good low temperature flexibility and medium damping. The major use of SPE I elastomer has been in vibration and shock mounts for the shipping container industry. This material has good retention of flexibility to temperatures as low as -65°F (-54°C). The high temperature limit for SPE I elastomer is typically +165°F (+74°C).

BTR® — This elastomer is LORD Corporation's original "Broad Temperature Range" elastomer. It is a silicone elastomer which was developed to have high damping and a wide span of operational temperatures. This material has an application range from -65°F to +300°F (-54°C to +149°C). The loss factor of this material is in the range of 0.32. This elastomer has been widely used in isolators for Military Electronics equipment for many years. It does not have the high load carrying capability of natural rubber but is in the high range for materials with this broad temperature range.

BTR® II — This material is similar in use to the BTR elastomer except that it has a slightly more limited temperature range and has less damping. BTR II may be used for most applications over a temperature range from -40°F to +300°F (-40°C to +149°C). The loss factor for typical BTR II compounds is in the range of 0.18. This elastomer has better returnability, less drift and better stability with temperature, down to -40°F (-40°C). The compromise with BTR II elastomer is the lower damping. This means that the resonant transmissibility of a system using BTR II elastomeric isolators will be higher than one using BTR isolators. At the same time, the high frequency isolation will be slightly better with the BTR II. This material has found use in Military Electronics isolators as well as in isolation systems for aircraft engines and shipboard equipment.

VIBRATION & SHOCK THEORY

BTR® VI — This is a very highly damped elastomer. It is a silicone elastomer of the same family as the BTR elastomer but is specially compounded to have loss factors in the 0.60 to 0.70 range. This would result in resonant transmissibility readings below 2.0 if used in a typical isolation system. This material is not used very often in applications requiring vibration isolation. It is most often used in products which are specifically designed for damping, such as lead-lag dampers for helicopter rotors. If used for a vibration isolator, BTR VI will provide excellent control of resonance but will not provide the degree of high frequency isolation that other elastomers will provide. The compromises here are that this material is quite strain and temperature sensitive, when compared to BTR and other typical Miltronics elastomers, and that it tends to have higher drift than the other materials.

“MEM” — This is an elastomer which has slightly less damping than LORD Corporation’s BTR silicone, but which also has less temperature and strain sensitivity. The typical loss factor for the MEM series of silicones is 0.29, which translates into a typical resonant transmissibility of 3.6 at room temperature and moderate strain across the elastomer. This material was developed by LORD at a time when some electronic guidance systems began to require improved performance stability of isolation systems across a broad temperature range, down to -70°F (-57°C), while maintaining a reasonable level of damping to control resonant response.

“MEA” — With miniaturization of electronic instrumentation, equipment became slightly more rugged and could withstand somewhat higher levels of vibration, but still required more constant isolator performance over a wide temperature range. These industry trends led to the development of LORD MEA silicone. As may be seen in the material property graphs of Figures 5 through 8, this elastomer family offers significant improvement in strain and temperature sensitivity over the BTR and MEM series. The compromise with the MEA silicone material is that it has less damping than the previous series. This results in typical loss factors in the range of 0.23 - resonant transmissibility of approximately 5.0. The MEA silicone also shows less drift than the standard BTR series elastomer.

“MEE” — This is another specialty silicone elastomer which was part of the development of materials for low temperature service. It has excellent consistency over a very broad temperature range – even better than the MEA material described above. The compromise with this elastomer is its low damping level. The typical loss factor for MEE is approximately 0.11, which results in resonant transmissibility in the range of 9.0. The low damping does give this material the desirable feature of providing excellent high frequency isolation characteristics along with its outstanding temperature stability.

With the above background, some of the properties of these elastomers, as they apply to the application of LORD isolators, will be presented. As with metals, elastomers have measurable modulus properties. The stiffness and damping characteristics of isolators are directly proportional to these moduli and vary as the moduli vary.

Strain, Temperature and Frequency Effects

— The engineering properties of elastomers vary with strain (the amount of deformation due to dynamic disturbance), temperature and the frequency of the dynamic disturbance. Of these three effects, frequency typically is the least and, for most isolator applications, can normally be neglected. Strain and temperature effects must be considered.

Strain Sensitivity — The general trend of dynamic modulus with strain is that modulus decreases with increasing strain. This same trend is true of the damping modulus. The ratio of the damping modulus to dynamic elastic modulus is approximately equal to the loss factor for the elastomer. The inverse of this ratio may be equated to the expected resonant transmissibility for the elastomer. This may be expressed as:

$$\frac{G''}{G'} \cong \eta$$
$$\frac{G'}{G''} \cong T_R$$

Where: G' = dynamic modulus (psi)
 G'' = damping (loss) modulus (psi)
 η = loss factor
 T_R = resonant transmissibility

more exactly:

$$T_R = \sqrt{\frac{1 + \eta^2}{\eta^2}}$$

VIBRATION & SHOCK THEORY

In general, resonant transmissibility varies only slightly with strain while the dynamic stiffness of an isolator may, depending on the elastomer, vary quite markedly with strain.

Figure 5 presents curves which depict the variation of the dynamic modulus of various elastomers which may be used in vibration isolators as related to the dynamic strain across the elastomer. These curves may be used to approximate the change in dynamic stiffness of an isolator due to the dynamic strain across the elastomer. This is based on the fact that the dynamic stiffness of an isolator is directly proportional to the dynamic modulus of the elastomer used in it. This relationship may be written as:

$$K'_S = \frac{AG'}{t_R}$$

Where: K'_S = dynamic shear stiffness (lb/in)
 G' = dynamic shear modulus of the elastomer (psi)
 t_R = elastomer thickness (in)
 A = load area of the elastomer (in²)

This variation may be used to calculate the change in a dynamic system's natural frequency from the equation:

$$f_n = 3.13 \sqrt{\frac{K'}{W}}$$

Where: f_n = system natural frequency (Hz)
 K' = total system dynamic spring rate (lb/in)
 W = total weight supported by the isolators (lb)

As there is a change in dynamic modulus, there is a variation in damping due to the effects of strain in elastomeric materials. One indication of the amount of damping in a system is the resonant transmissibility of that system. Figure 6 shows the variation in resonant transmissibility due to changes in vibration input for the elastomers typically used in LORD military electronics isolators.

The data presented in Figures 5 and 6 lead to some conclusions about the application of vibration isolators. The following must be remembered when analyzing or testing an isolated system:

- It is important to specify the dynamic conditions under which the system will be tested.
- The performance of the isolated system will change if the dynamic conditions (such as vibration input) change.
- The change in system performance due to change in dynamic environment may be estimated with some confidence.

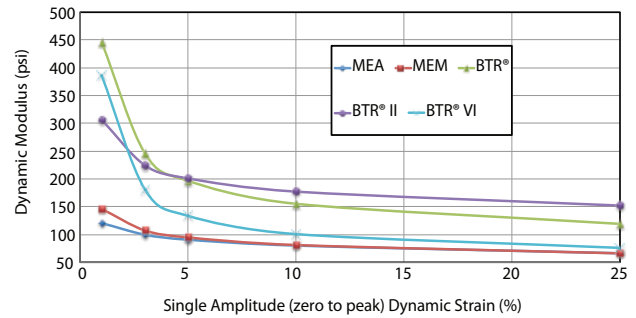

FIGURE 5 – TYPICAL DYNAMIC ELASTIC MODULUS VALUES FOR LORD VIBRATION ISOLATOR ELASTOMERS

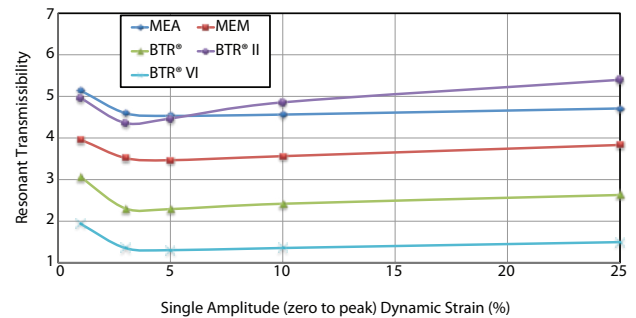

FIGURE 6 – TYPICAL RESONANT TRANSMISSIBILITY VALUES FOR LORD VIBRATION ISOLATOR ELASTOMERS

VIBRATION & SHOCK THEORY

Temperature Sensitivity — Temperature, like strain, will affect the performance of elastomers and the systems in which elastomeric isolators are used. Figures 7 and 8 show the variations of dynamic modulus and resonant transmissibility with temperature and may be used to estimate system performance changes as may Figures 5 and 6 in the case of strain variation.

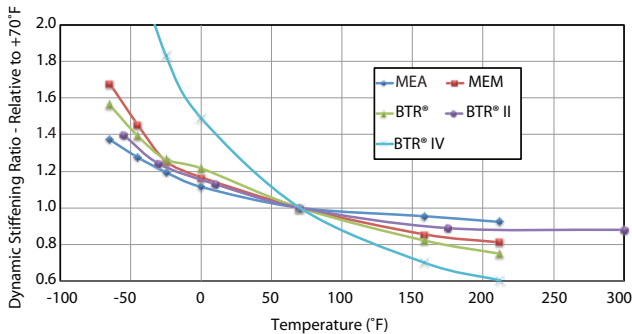

FIGURE 7 –
TYPICAL TEMPERATURE CORRECTIONS FOR
LORD VIBRATION ISOLATOR ELASTOMERS

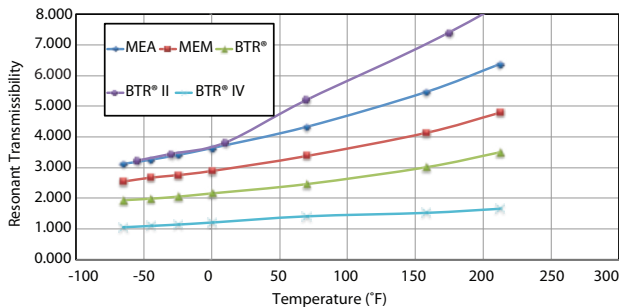

FIGURE 8 –
TRANSMISSIBILITY VS. TEMPERATURE FOR
LORD VIBRATION ISOLATOR ELASTOMERS

Modifications to Theory Based on the Real World

It should be apparent from the preceding discussion that the basic assumption of linearity in dynamic systems must be modified when dealing with elastomeric vibration isolators. These modifications do affect the results of the analysis of an isolated system and should be taken into account when writing specifications for vibration isolators. It should also be noted that similar effects of variation with vibration level have been detected with “metal mesh” isolators.

Thus, care must be exercised in applying them. The amount of variability of these isolators is somewhat different than with elastomeric isolators and depends on too many factors to allow simple statements to be made.

The following discussion will be based on the properties of elastomeric isolators.

Static Stiffness versus Shock Stiffness versus Vibration Stiffness

— Because of the strain and frequency sensitivity of elastomers, elastomeric vibration and shock isolators perform quite differently under static, shock or vibration conditions.

The equation:

$$d_{\text{static}} = \frac{9.8}{f_n^2}$$

Where: d_{static} = static deflection of the system (in)
 f_n = system natural frequency (Hz)

DOES NOT HOLD for elastomeric vibration/shock isolators. The static stiffness is typically less than the dynamic stiffness for these materials. To say this another way, the static deflection will be higher than expected if it were calculated, using the above formula, based on a vibration or shock test of the system.

Similarly, neither the static nor the vibration stiffness of such devices is applicable to the condition of shock disturbances of the system. It has been found empirically that:

$$K'_{\text{shock}} \cong 1.4K_{\text{static}}$$

The difference in stiffness between vibration and static conditions depends on the strain imposed by the vibration on the elastomer. Figure 5 shows where the static modulus will lie in relation to the dynamic modulus for some typical elastomers at various strain levels.

What this means to the packaging engineer or dynamicist is that one, single stiffness value cannot be applied to all conditions and that the dynamic to static stiffness relationship is dependent on the particular isolator being considered. What this means to the isolator designer is that each condition of use must be separately analyzed with the correct isolator stiffness for each condition.

VIBRATION & SHOCK THEORY

Shock Considerations — As stated in the previous discussion, shock analyses for systems using elastomeric isolators should be based on the guideline that the isolator stiffness will be approximately 1.4 times the static stiffness. In addition to this, it must be remembered that there must be enough free deflection in the system to allow the shock energy to be stored in the isolators.

If the system should bottom, the “g” level transmitted to the mounted equipment will be much higher than would be calculated. In short, the system must be allowed to oscillate freely once it has been exposed to a shock disturbance to allow theory to be applied appropriately. Figure 9 shows this situation schematically.

In considering the above, several items should be noted:

- Damping in the system will dissipate some of the input energy and the peak transmitted shock will be slightly less than predicted based on a linear, undamped system.
- “ τ ” is the shock input pulse duration (seconds).
- “ t_n ” is one-half of the natural period of the system (seconds).
- There must be enough free deflection allowed in the system to store the energy without bottoming (snubbing). If this is not considered, the transmitted shock may be significantly higher than calculated and damage may occur in the mounted equipment.

Vibration Considerations — The performance of typical elastomeric isolators changes with changes in dynamic input – the level of vibration to which the system is being subjected. This is definitely not what most textbooks on vibration would imply. The strain sensitivity of the elastomers causes the dynamic characteristics to change.

Figure 10 is representative of a model of a vibratory system proposed by Professor Snowdon of Penn State University in his book, “Vibration and Shock in Damped Mechanical Systems.” This model recognized the changing properties of elastomers and the effects of these changes on the typical vibration response of an isolated system. These effects are depicted in the comparison of a theoretically calculated transmissibility response curve to one resulting from a test of an actual system using elastomeric isolators.

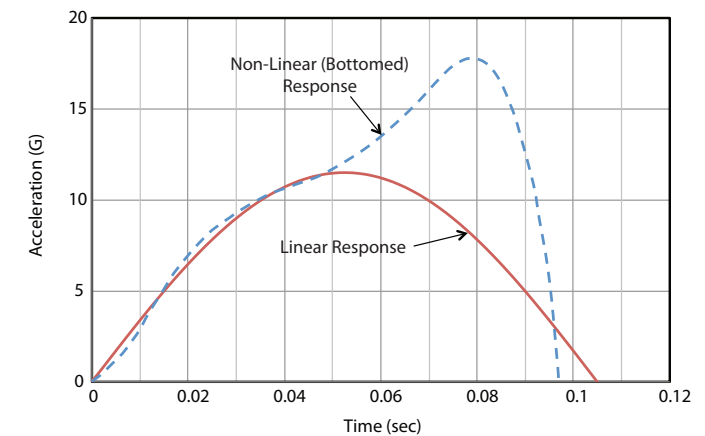
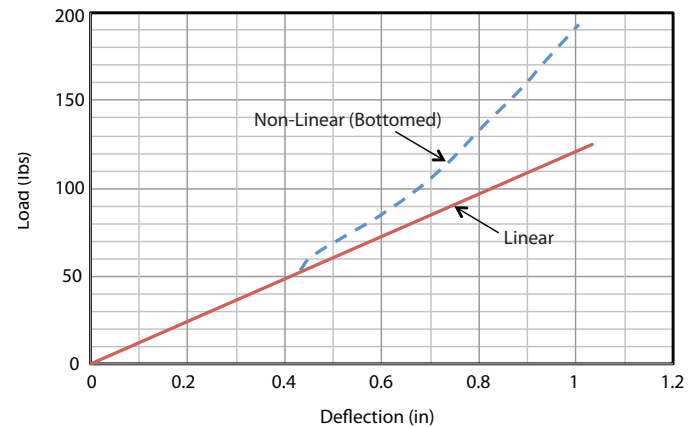
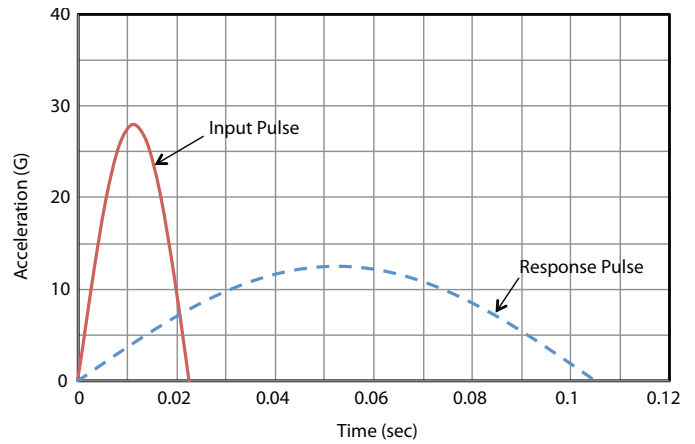

FIGURE 9

VIBRATION & SHOCK THEORY

The Real World

The majority of vibration and shock isolators are those utilizing elastomeric elements as the source of compliance and damping to control system responses.

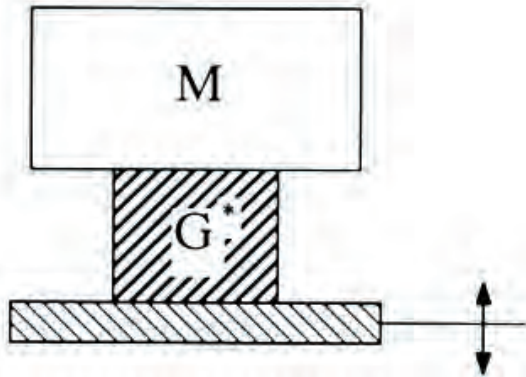

FIGURE 10

G^* is "Complex Modulus" (see Figure 10)

$$G^* = G' + jG''$$

or

$$G^* = G'(1 + j\eta)$$

Where: η = loss factor

$$\eta \cong \frac{G''}{G'} \cong 2\zeta$$

Where: G'' = damping modulus (psi)
 G' = dynamic modulus (psi)
 ζ = damping factor (dimensionless)

Using this model, we may express the absolute transmissibility of the system as:

$$T_{ABS} = \frac{\sqrt{1 + \eta^2}}{\sqrt{[1 - r^2 \frac{G'}{G'_n}]^2 + \eta^2}}$$

Where: G'_n = dynamic modulus (psi) at the particular vibration condition being analyzed

The resulting transmissibility curve from such a treatment, compared to the classical, theoretical transmissibility curve, is shown in Figure 11.

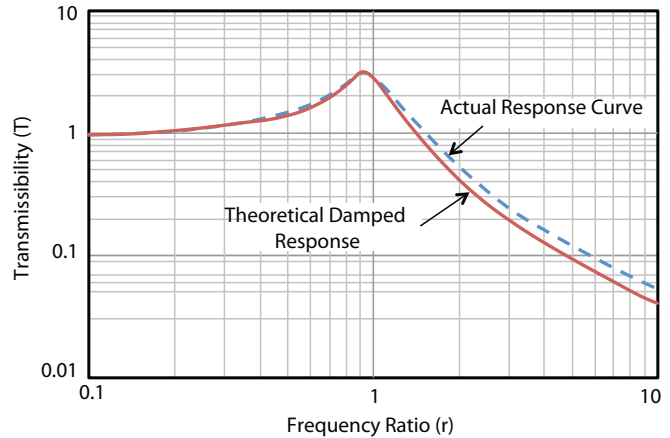

FIGURE 11 –
EFFECT OF MATERIAL SENSITIVITY ON
TRANSMISSIBILITY RESPONSE

Two important conclusions may be reached on the basis of this comparison:

1. The "crossover" point of the transmissibility curve ($T_{ABS} = 1.0$) occurs at a frequency higher than $\sqrt{2}$ times the natural frequency which is what would be expected based on classical vibration theory. This crossover frequency will vary depending on the type of vibration input and the temperature at which the test is being conducted.
2. The degree of isolation realized at high frequencies ($T_{ABS} < 1.0$) will be less than calculated for an equivalent level of damping in a classical analysis. This slower "roll-off" rate " $\frac{dB}{octave}$ " will also depend on the type of elastomer, level and type of input and temperature.

VIBRATION & SHOCK THEORY

In general, a constant amplitude sinusoidal vibration input will have less effect on the transmissibility curve than a constant 'g' (acceleration) vibration input. The reason is that, with increasing frequency, the strain across the elastomer is decreasing more rapidly with the constant 'g' input than with a constant amplitude input. Remembering the fact that decreasing strain causes increasing stiffness in elastomeric isolators, this means that the crossover frequency will be higher and the roll-off rate will be lower for a constant 'g' input than for a constant amplitude input. Figure 12 is representative of these two types of vibration inputs as they might appear in a test specification.

No general statement of where the effects of random vibration will lead in relationship to a sinusoidal constant 'g' or constant amplitude vibration input can be made. However, the effects will be similar to a sinusoidal vibration since random vibrations typically produce lower strains across isolators as frequency increases. There may be some exceptions to this statement. In the section, Determining Necessary Characteristics of Vibration/ Shock Isolator, guidance is provided as how to apply the properties of elastomers to the various conditions which may be specified for a typical installation requiring isolators.

Data Required to Select or Design a Vibration/Shock Isolator — As with any engineering activity, the selection or design of an isolator is only as good as the information on which that selection or design is based. Figure 13 is an example of one available LORD checklist for isolator applications (refer to Questionnaire section for actual questionnaire).

If the information on this checklist is provided, the selection of an appropriate isolator can be aided greatly, both in timeliness and suitability.

Checklist Section I provides the information about the equipment to be mounted (its size, weight and inertias) and the available space for the isolation system to do its job. This latter item includes isolator size and available sway space for equipment movement.

Checklist Section II tells the designer what the dynamic disturbances are and how much of those disturbances the equipment can withstand. The difference is the function of the isolation system.

It is important to note here that the random vibration must be provided as a power spectral density versus frequency tabulation or graph, not as an overall " g_{RMS} " level, in order to allow analysis of this condition. Also, note that the U.S. Navy "high impact" shock test is

required by specification MIL-S-901 for shipboard equipment.

Checklist Section III contains space for descriptions of any special environmental exposures which the isolators must withstand. Also, for critical applications, such as gyros, optics and radar isolators, the requirements for control of angular motion of the isolated equipment are requested. In such cases, particular effort should be made to keep the elastic center of the isolation system and the center-of-gravity of the equipment at the same point. The vibration isolators may have their dynamic properties closely matched in order to avoid the introduction of angular errors due to the isolation system itself.

All of the information listed on the checklist shown in Figure 13 is important to the selection of a proper vibration isolator for a given application. As much of the information as possible should be supplied as early as possible in the design or development stage of your equipment. Of course, any drawings or sketches of the equipment and the installation should also be made available to the vibration/shock analyst who is selecting or designing isolators.

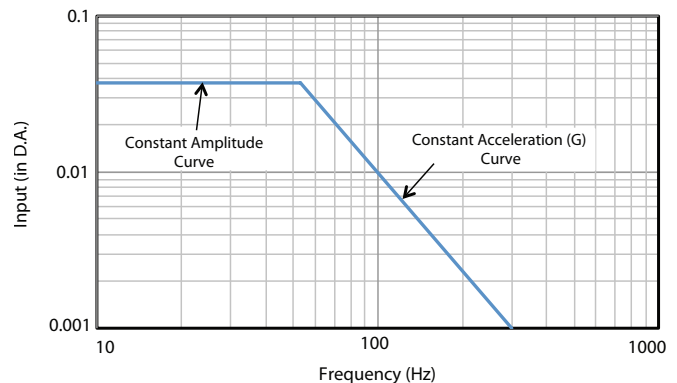

FIGURE 12 –
COMPARISON-CONSTANT AMPLITUDE
TO CONSTANT "G" VIBRATION INPUT

VIBRATION & SHOCK THEORY

Engineering Data for Vibration and Shock Isolator Questionnaire

Please fill in as much detail as possible before contacting LORD. You may fax or e-mail this completed form.

For technical assistance, contact: LORD Corporation; Application Engineering; 2000 West Grandview Blvd.; Erie, PA 16514; Phone: +1 877 ASK LORD (275 5673) in United States and Canada; Fax: +1 814 860 3871; E-mail: customer.support@lord.com

I. PHYSICAL DATA

- A. Equipment weight _____
- B. C.G. location relative to mounting points _____
- C. Sway space _____
- D. Maximum mounting size _____
- E. Equipment and support structure resonance frequencies _____
- F. Moment of inertia through C.G. for major axes (necessary for natural frequency and coupling calculations)
I_{xx} _____ I_{yy} _____ I_{zz} _____
- G. Fail-safe installation required? Yes No

II. DYNAMICS DATA

- A. Vibration requirement:
 - 1. Sinusoidal inputs (specify sweep rate, duration and magnitude or application input specification curve) _____
 - 2. Random inputs (specify duration and magnitude (g²/Hz) applicable input specification curve) _____
- B. Resonant dwell (input & duration) _____
- C. Shock requirement:
 - 1. Pulse shape _____ pulse period _____ amplitude _____
number of shocks per axis _____ maximum output _____
 - 2. Navy high impact required? (if yes, to what level?) _____
- D. Sustained acceleration: magnitude _____ direction _____
Superimposed with vibration? Yes No
- E. Vibration fragility envelope (maximum G vs. frequency preferred) or desired natural frequency and maximum transmissibility _____
- F. Maximum dynamic coupling angle _____
matched mount required? Yes No
- G. Desired returnability _____
Describe test procedure _____

III. ENVIRONMENTAL DATA

- A. Temperature: Operating _____ Non-operating _____
- B. Salt spray per MIL _____ Humidity per MIL _____
Sand and dust per MIL _____ Fungus resistance per MIL _____
Oil and/or gas _____ Fuels _____
- C. Special finishes on components _____

FIGURE 13 -
SAMPLE OF ENGINEERING DATA FOR VIBRATION AND
SHOCK ISOLATOR QUESTIONNAIRE*

* For actual questionnaire, refer to Questionnaire section.

VIBRATION & SHOCK THEORY

Determining Necessary Characteristics of a Vibration/Shock Isolator

The fragility of the equipment to be isolated is typically the determining factor in the selection or design of an isolator. The critical fragility level may occur under vibration conditions or shock conditions. Given one of these starting points, the designer can then determine the dynamic properties required of isolators for the application. Then, knowing the isolator required, the designer may estimate the remaining dynamic and static performance properties of the isolator and the mounted system.

The following sections will present a method for analyzing the requirements for an isolation problem and for selecting an appropriate isolator.

Sinusoidal Vibration Fragility as the Starting Point — A system specification, equipment operation requirements or a known equipment fragility spectrum may dictate what the system natural frequency must, or may, be. Figure 14 shows a fictitious fragility curve superimposed on a typical vibration input curve. Isolation system requirements may be derived from this information.

First, the allowable transmissibility at any frequency may be calculated as the ratio of the allowable output to the specified input.

$$T_{ABS} = \frac{X_o}{X_i} \text{ or } \frac{g_o}{g_i}$$

The frequency at which this ratio is a maximum is one frequency at which the system natural frequency may be placed (assuming that it is greater than approximately 2.5, at some frequency). Another method of placing the system natural frequency is to select that frequency which will allow the isolation of the input over the required frequency range. A good rule of thumb is to select a frequency which is at least a factor of 2.0 below that frequency where the allowable response (output) crosses over – goes below – the specified input curve.

Having determined an acceptable system natural frequency, the system stiffness (spring rate) may be calculated from the following relationship:

$$K' = \frac{(f_n)^2 (W)}{9.8}$$

Where: K' = total system dynamic stiffness (lb/in) at the specified vibration input
 f_n = selected system natural frequency (Hz)
 W = isolated equipment weight (lb)

An individual isolator spring rate may then be determined by dividing this system spring rate by the allowable, or desired number of isolators to be used. The appropriate isolator may then be selected based on the following factors:

- required dynamic spring rate
- specified vibration input at the desired natural frequency of the system
- static load supported per isolator
- allowable system transmissibility
- environmental conditions (temperature, fluid exposure, etc.)

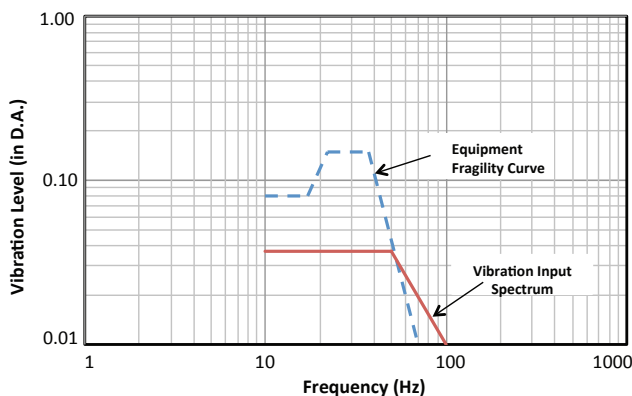

FIGURE 14 – EQUIPMENT FRAGILITY VS. VIBRATION INPUT

VIBRATION & SHOCK THEORY

Once a particular isolator has been selected, the properties of the elastomer in the isolator may be used to estimate the performance of the isolator at other conditions of use, such as other vibration levels, shock inputs, steady state acceleration loading and temperature extremes. The necessary elastomer property data are found in Figures 5, 6, 7 and 8.

If the vibration input in the region of the required natural frequency is specified as a constant acceleration – constant ‘g’ – it may be converted to a motion input through the equation:

$$X_i = \frac{g_i}{(0.051)(f_n)^2}$$

Where: X_i = vibratory motion (inches, double amplitude)
 g_i = specified vibratory acceleration input (g)
 f_n = desired system natural frequency (Hz)

Of course, this equation may be used to convert constant acceleration levels to motions at any frequency. It is necessary to know this vibratory motion input in order to select or design an isolator. Note, that most catalog vibration isolators are rated for some maximum vibration input level expressed in inches double amplitude. Also, the listed dynamic stiffnesses for many standard isolators are given for specific vibration inputs. This information provides a starting point on Figure 5 to allow calculation of the system performance at vibration levels other than that listed for the isolator.

Random Vibration Performance as the Starting Point — Random vibration is replacing sinusoidal vibration in specifications for much of today’s equipment. A good example is MIL-STD-810. Many of the vibration levels in the most recent version of this specification are given in the now familiar format of “power spectral density” plots. Such specifications are the latest attempt to simulate the actual conditions facing sensitive equipment in various installations.

A combination of theory and experience is used in the analysis of random vibration. As noted previously, the random input must be specified in the units of “g²/Hz” in order to be analyzed and to allow proper isolator selection. The system natural frequency may be determined by a fragility versus input plot of random vibration just as was done and demonstrated in Figure 14 for sinusoidal vibration. Once the required natural frequency is known, the necessary isolator spring rate may again be calculated from the equation:

$$K' = \frac{(f_n)^2 (W)}{9.8}$$

The next steps in determining which isolator may be used are to calculate the allowable transmissibility and the motion at which the isolated system responds at the same natural frequency as when it is subjected to the specified random vibration. The allowable transmissibility, if not already specified, may be calculated from the input vibration and the allowable vibration by using the equation:

$$T_R = \sqrt{\frac{S_o}{S_i}}$$

Where: T_R = resonant transmissibility (dimensionless)
 S_o = output random vibration (g²/Hz)
 S_i = input random vibration (g²/Hz)

A sinusoidal vibration input, acceleration or motion, at which the system will respond at approximately the same natural frequency with the specified random vibration may be calculated in the following manner.

STEP 1: The analysis of random vibration is made on the basis of probability theory. The one sigma (1σ) root mean square (RMS) acceleration response may be calculated from the equation:

$$g_{oRMS} = \sqrt{(\pi/2)(S_i)(f_n)(T_R)}$$

Where: g_{oRMS} = 1σ RMS acceleration response (g)
 S_i = input random vibration (g²/Hz)
 T_R = allowable resonant transmissibility
 f_n = desired natural frequency (Hz)

STEP 2: It has been found empirically that elastomeric isolators typically respond at a 3σ vibration level. Thus, the acceleration vibration level at which the system will respond at approximately the same natural frequency as with the specified random level may be found to be:

$$g_{o3\sigma} = 3\sqrt{(\pi/2)(S_i)(f_n)(T_R)}$$

STEP 3: The above is response acceleration. To find the input for this condition of response, we simply divide by the resonant transmissibility.

$$g_i = \frac{g_{o3\sigma}}{T_R}$$

VIBRATION & SHOCK THEORY

STEP 4: Finally, we apply the equation from a previous section to calculate the motion input vibration equivalent to this acceleration at the system natural frequency:

$$X_i = \frac{g_i}{(0.051)(f_n)^2}$$

Note that X_i is in units of inches double amplitude.

STEP 5: The analysis can now follow the scheme of previous calculations to find the appropriate isolator and then analyze the shock, static and temperature performance of the isolator.

Shock Fragility as the Starting Point — If the fragility of the equipment in a shock environment is the critical requirement of the application, the natural frequency of the system will depend on the required isolation of the shock input.

STEP 1: Calculate the necessary shock transmissibility:

$$T_s = \frac{G_o}{G_i}$$

Where: T_s = shock transmissibility (dimensionless)
 G_o = equipment fragility (g)
 G_i = input shock level (g)

STEP 2: Calculate the required *shock* natural frequency. This depends on the shape of the shock pulse.

The following approximate equations *may be used only* for values of $T_s < 1.0$:

Pulse Shape	Transmissibility Equation
Half Sine	$T_s \cong 4(f_n)(\tau)$
Square Wave	$T_s \cong 6(f_n)(\tau)$
Triangular	$T_s \cong 3.1(f_n)(\tau)$
Ramp or Blast	$T_s \cong 3.2(f_n)(\tau)$

Where: T_s = shock transmissibility
 f_n = shock natural frequency (Hz)
 τ = shock pulse length (seconds)

Remember, that the system natural frequency under a shock condition will typically be different from that under a vibration condition for systems using elastomeric vibration isolators.

STEP 3: Calculate the required deflection to allow this level of shock protection by the equation:

$$d_{\text{shock}} = \frac{G_o}{(0.102)(f_n)^2}$$

Where: d_{shock} = shock deflection (inches single amplitude)
 G_o = shock response or equipment fragility (g)
 f_n = shock natural frequency (Hz)

STEP 4: Calculate the required dynamic spring rate necessary under the specified shock condition from the equation:

$$K' = \frac{(f_n)^2(W)}{9.8}$$

Where: K' = dynamic stiffness (lb/in)
 f_n = shock natural frequency (Hz)
 W = supported weight (lb)

STEP 5: Select the proper isolator from those available in the product section, that is, one which has the required dynamic stiffness (K'), will support the specified load and will allow the calculated deflection (d_{shock}) without bottoming during the shock event.

STEP 6: Determine the dynamic stiffness (K') of the chosen isolator, at the vibration levels specified for the application, by applying Figure 5 with the knowledge that dynamic spring rate is directly proportional to dynamic modulus (G') and by working from a known dynamic stiffness of the isolator at a known dynamic motion input.

STEP 7: Calculate system natural frequencies under specified vibration inputs from the equation:

$$f_n = 3.13 \sqrt{\frac{K'}{W}}$$

Where: f_n = vibration natural frequency (Hz)
 K' = isolator dynamic stiffness at the specified vibration level (lb/in)
 W = supported weight (lb)

VIBRATION & SHOCK THEORY

Note that the stiffness and supported weight must be considered on the same terms, i.e., if the stiffness is for a single mount, then the supported weight must be that supported on one mount. Once the system natural frequency is calculated, the system should be analyzed to determine what effect this resonance will have on the operation and/or protection of the equipment.

STEP 8: Estimate the static stiffness of the isolators from the relationship:

$$K \approx \frac{K'_{\text{shock}}}{1.4}$$

Where: **K** = static stiffness (lb/in)
K'_{shock} = shock dynamic stiffness (lb/in)

Then, check the deflection of the system under the 1g load and under any steady-state (maneuver) loads from the equation:

$$d_{\text{static}} = \frac{g_n W}{K}$$

Where: **d_{static}** = static deflection (inches)
g_n = number of g's loading being imposed
W = supported load (lb)
K = static spring rate (lb/in)

Be sure that the chosen isolator has enough deflection capability to accommodate the calculated motions without bottoming. If the vibration isolation function and steady state accelerations must be imposed on the system simultaneously, the total deflection capability of the isolator must be adequate to allow the deflections from these two sources combined. Thus,

$$d_{\text{total}} = d_{\text{vib}} + d_{\text{static}}$$

where $d_{\text{vib}} = \frac{X_i}{2} T_R$

Where: **X_i** = input vibration motion at resonance (inches double amplitude)
d_{vib} = deflection due to vibration (inches single amplitude)
T_R = resonant transmissibility
d_{static} = static deflection per the above equation (inches)

Types of Isolators and Their Properties —

There are a number of different types of isolators, based on configuration, that may be applied in supporting and protecting various kinds of equipment. Depending on the severity of the application and on the level of protection required for the equipment, one or another of these mounting types may be applied.

Figures 15, 16 and 17 show some of the most common “generic” configurations of vibration isolators and the characteristic load versus deflection curves for the simple shear mounting and the “buckling column” types of isolators. In general, the fully bonded or holder types of isolators are used for more critical equipment installations because these have superior performance characteristics as compared to the center bonded or unbonded configurations. The buckling column type of isolator is useful in applications where high levels of shock must be reduced in order to protect the mounted equipment. Many aerospace equipment isolators are of the conical type because they are isoelastic.

In order of preference for repeatability of performance, the rank of the various isolator types is:

1. Fully Bonded
2. Holder Type
3. Center Bonded
4. Unbonded

In reviewing the standard lines of LORD isolators, the Low Profile Avionics (AM Series), Pedestal (PS Series), Plate Form (100 & 150 Series), Multiplane (106 & 156 Series), High Deflection (HDM & MHDM Series), Miniature (MAA Series) and Micro-Mounts (MX Series) are in the fully bonded category. The BTR (HT Series) mounts are the only series in the holder type category. The Miniature MCB Series of isolators is the offering in the center bonded type of mount. The Miniature MGN/MGS Series mounts are in the unbonded mount category. In total, these standard offerings from LORD cover a wide range of stiffnesses and load ratings to satisfy the requirements of many vibration and shock isolation applications.

In some instances, there may be a need to match the dynamic stiffness and damping characteristics of the isolators which are to be used on any particular piece of equipment. Some typical applications of matched sets of isolators are gyros, radars and optics equipment. For these applications, the fully bonded type of isolator construction is highly recommended. The dynamic performance of these mounts is much more consistent than other types. Dynamically matched isolators are supplied in sets but are not standard since matching requirements are rarely the same for any two applications.

VIBRATION & SHOCK THEORY

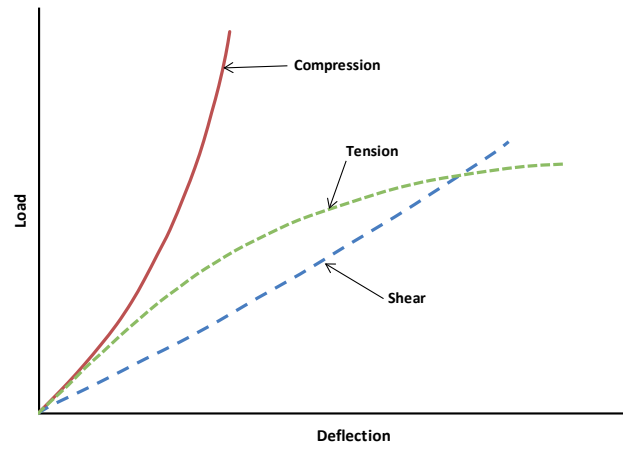
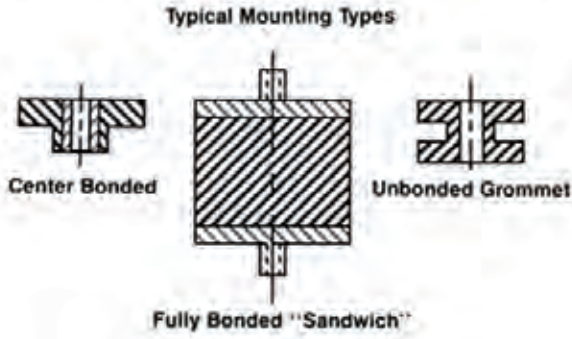

FIGURE 15 – TYPICAL LOAD / DEFLECTION CURVES FOR "SANDWICH" MOUNTS

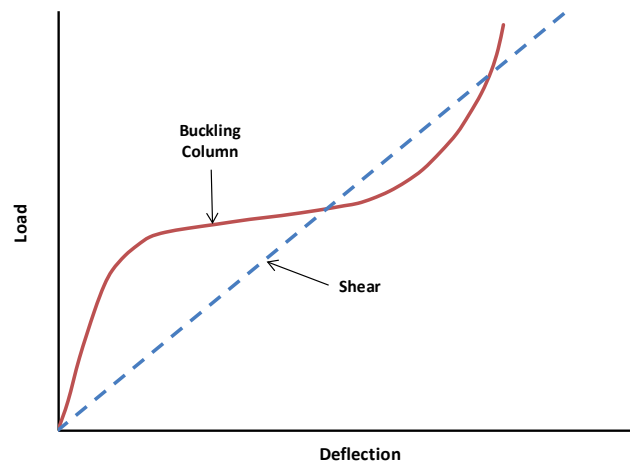
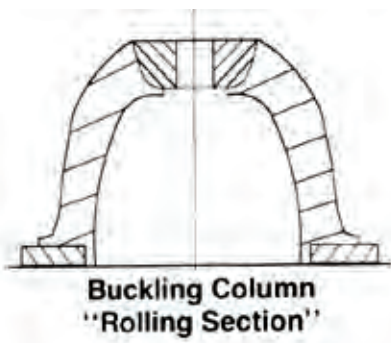

FIGURE 17 – TYPICAL LOAD / DEFLECTION CURVES FOR "ROLLING SECTION" MOUNTS

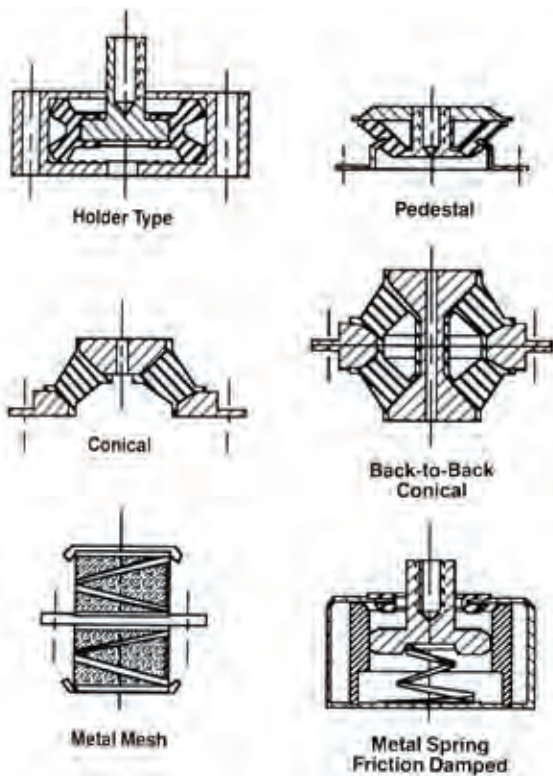

FIGURE 16 – TYPICAL MOUNTING TYPES

Sample Application Analysis — Figure 18 is a completed checklist of information for a fictitious piece of avionics gear installed in an aircraft environment. The following section will demonstrate how the foregoing theory and data may be applied to the selection of a standard LORD mount.

VIBRATION & SHOCK THEORY

Engineering Data for Vibration and Shock Isolator Questionnaire

Please fill in as much detail as possible before contacting LORD. You may fax or e-mail this completed form.

For technical assistance, contact: LORD Corporation; Application Engineering; 2000 West Grandview Blvd.; Erie, PA 16514; Phone: +1 877 ASK LORD (275 5673) in United States and Canada; Fax: +1 814 860 3871; E-mail: customer.support@lord.com

I. PHYSICAL DATA

- A. Equipment weight 12 lb
- B. C.G. location relative to mounting points Geometric Center – Four Mounts Desired
- C. Sway space ±0.32"
- D. Maximum mounting size 1" High x 2" Long x 2" Wide
- E. Equipment and support structure resonance frequencies 400 Hz
- F. Moment of inertia through C.G. for major axes (necessary for natural frequency and coupling calculations)
I_{xx} _____ I_{yy} _____ I_{zz} _____
- G. Fail-safe installation required? Yes No

II. DYNAMICS DATA

- A. Vibration requirement:
- Sinusoidal inputs (specify sweep rate, duration and magnitude or application input specification curve)
0.036" D.A., 5 to 52 Hz; 5G, 52 to 500 Hz
 - Random inputs (specify duration and magnitude (g²/Hz) applicable input specification curve)
0.04 g²/Hz; 10 to 300 Hz
- B. Resonant dwell (input & duration) 0.036" D.A., 1/2 hr. per Axis
- C. Shock requirement:
- Pulse shape Half Sine pulse period 11 ms amplitude 15G
number of shocks per axis 3/Axis maximum output N/A
 - Navy high impact required? (if yes, to what level?) N/A
- D. Sustained acceleration: magnitude 3G direction all directions
Superimposed with vibration? Yes No
- E. Vibration fragility envelope (maximum G vs. frequency preferred) or desired natural frequency and maximum transmissibility
32 Hz with T less than 4
- F. Maximum dynamic coupling angle N/A
matched mount required? Yes No
- G. Desired returnability N/A
Describe test procedure N/A

III. ENVIRONMENTAL DATA

- A. Temperature: Operating +30° to +120°F Non-operating -40° to +160°F
- B. Salt spray per MIL 810C Humidity per MIL 810C
Sand and dust per MIL 810C Fungus resistance per MIL 810C
Oil and/or gas N/A Fuels N/A
- C. Special finishes on components N/A

FIGURE 18 –
SAMPLE OF COMPLETED ENGINEERING DATA FOR VIBRATION
AND SHOCK ISOLATOR QUESTIONNAIRE

CONSIDER VIBRATION REQUIREMENTS

Consider Sinusoidal Vibration Requirements

From the checklist (see Figure 18), it is noted that the desired system natural frequency is 32 Hz with a maximum allowable transmissibility of 4.0, or less.

STEP 1: Determine the required dynamic spring rate:

$$K' = \frac{(f_n)^2(W)}{9.8}$$

$$f_n = 32 \text{ Hz}$$

$$W = 12 \text{ lb}$$

$$K' = \frac{(32)^2(12)}{9.8} = 1254 \text{ lb/in}$$

Note that this figure is the total system spring rate since the weight used in the calculation was the total weight of the supported equipment. The checklist indicates that four (4) isolators will be used to support this unit. Thus, the required isolator is to have a dynamic stiffness of:

$$K' = \frac{1254}{4} = 314 \text{ lb/in/isolator}$$

at the vibration input of 0.036 inch double amplitude as specified in Section II.A.1 of the checklist.

STEP 2: Make a *tentative* isolator selection.

Thus far, it is known that:

1. The isolator must have a dynamic spring rate of 314 lb/in.
2. The supported static load per isolator is 3 pounds.
3. The material, or construction, of the isolator must provide enough damping to control resonant transmissibility to 4.0 or less.
4. There is no special environmental resistance required.

Choosing a relatively small isolator available from those which meet the above requirements, the AM003-7, in BTR elastomer, is selected from the Low Profile Avionics Mounts (AM Series) section. The analysis now proceeds to consideration of other specified conditions.

Consider Random Vibration Requirements

Calculate a sinusoidal motion input at the desired natural frequency with the specified random vibration input and compare it to the specified sine vibration. Both the maximum motion and the input motion which would cause the isolator to respond at approximately the same natural frequency as the random vibration should be calculated. The maximum is calculated to check that the selected isolator will have enough deflection capability and the resonant motion is calculated to verify the stiffness of the required isolator at the actual input at which it will respond to the random vibration.

Per the previously presented material, the isolator should respond at a 3σ equivalent acceleration – calculated on the basis of the specified random vibration at the desired natural frequency. This level will determine, in part, the isolator choice. The calculation is made as follows:

$$g_{0.3\sigma} = 3\sqrt{(\pi/2)(S_i)(f_n)(T_R)}$$

Where: $S_i = 0.04 \text{ g}^2/\text{Hz}$
 $T_R = 2.9$ (per Figure 6 for BTR at typical operating strain)
 $f_n = 32 \text{ Hz}$

$$g_{0.3\sigma} = 3\sqrt{(\pi/2)(0.04)(32)(2.9)}$$

$$g_{0.3\sigma} = 7.24g$$

This is the acceleration *response* at the desired natural frequency of 32 Hz. The motion across the isolator due to this response may be calculated as:

$$X_{0.3\sigma} = g_{0.3\sigma} / (0.051)(f_n)^2$$

$$X_{0.3\sigma} = 0.139 / (0.051)(32)^2$$

$$X_{0.3\sigma} = 0.139 \text{ inch double amplitude}$$

VIBRATION & SHOCK THEORY

The ultimately selected isolator must have enough deflection capability to allow this motion without bottoming (snubbing). The input acceleration is calculated as:

$$g_{i3\sigma} = g_{o3\sigma} / T_R$$

$$g_{i3\sigma} = 7.24 / 2.9$$

$$g_{i3\sigma} = 2.5g$$

and the input motion as:

$$X_{i3\sigma} = g_{i3\sigma} / (0.051)(f_n)^2$$

$$X_{i3\sigma} = 2.5 / (0.051)(32)^2$$

$$X_{i3\sigma} = 0.048 \text{ inch double amplitude}$$

This vibration level is higher than the capability of the tentatively selected AM003-7. To remain with a relatively small isolator which will support 3 pounds, withstand the 0.047 inch double amplitude sine vibration and provide an approximate stiffness of 314 lb/in per mounting point, a selection from either the AM002 or AM004 series appears to be best.

Since none of the single isolators provides enough stiffness, a back to back (parallel) installation of a pair of isolators at each mounting point is suggested. Since the AM002 is smaller than the AM004, and is rated for 0.06 inch double amplitude maximum input vibration, the selection of the AM002-8 isolator is made. A pair of the AM002-8 isolators will provide a stiffness of 346 lb/in (two times 173 per the stiffness chart in the product section). This stiffness would provide a slightly higher natural frequency than desired. However, there is a correction to be made, based on the calculated vibration input.

The stiffnesses in the AM002 product chart are based on an input vibration of 0.036 inch double amplitude. Figure 5 shows that the modulus of the BTR elastomer is sensitive to the vibration input. The modulus is directly proportional to the stiffness of the vibration isolator. Thus, the information of Figure 5 may be used to estimate the performance of an isolator at an "off-spec" condition. A simple graphical method may be used to estimate the performance of an isolator at such a condition.

Knowing the geometry of the isolator, the strain at various conditions may be estimated. The modulus versus strain information of Figure 5 and the knowledge of the relationship of modulus to natural frequency (via the stiffness of the isolator) are used to construct the graph of the isolator characteristic. The equation for calculation of the 3σ random equivalent input at various frequencies has been shown previously. The crossing point of the two lines on the graph shown in Figure 19 is a reasonable estimate for the response natural frequency of the selected isolator under the specified 0.04 g²/Hz random vibration.

The intersection of the plotted lines in Figure 19 is at a frequency of approximately 32 to 33 Hz, and at an input vibration level of approximately 0.047 inch DA. This matches the desired system natural frequency and confirms the selection of the AM002-8 for this application. In all, eight (8) pieces of the AM002-8 will be used to provide the 32 Hz system natural frequency, while supporting a total 12 lb unit, under the specified random vibration of 0.04 g²/Hz. The eight isolators will be installed in pairs at four locations. With this portion of the analysis complete, the next operating condition – shock – is now considered.

NOTE: Where L/D curves are not specified, dynamic spring rate can be used.

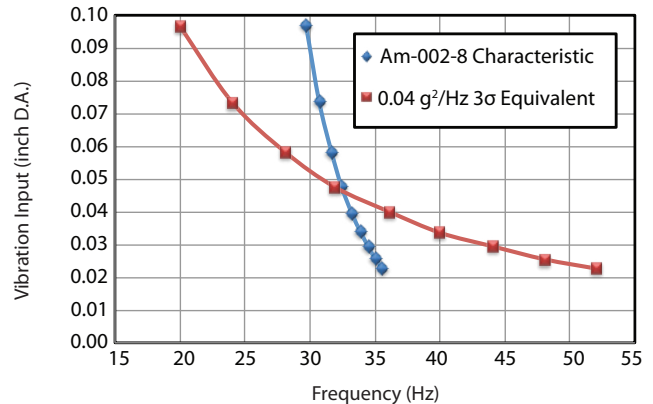

FIGURE 19

CONSIDER SHOCK REQUIREMENTS

The specified shock input is a 15g, 11 ms, half-sine pulse. From the previously presented theory, an approximation of the shock response may be found through the use of the equation:

$$T_s \approx 4f_n \tau$$

Note that the natural frequency to be used here is the *shock natural frequency* which may be estimated from the information given in Figure 5. The dynamic modulus for the elastomer used here is approximately 120 psi at a vibration level of 0.036 inch double amplitude and the static modulus is approximately 80 psi.

From this information, the static stiffness of the isolator may be estimated as follows:

$$K = \left(\frac{80}{120} \right) (K')$$

$$K = \left(\frac{80}{120} \right) \left(\frac{(f_n)^2 W}{9.8} \right)$$

$$K = \left(\frac{80}{120} \right) \left(\frac{(32)^2 (12)}{9.8} \right) = 836 \text{ lb/in for the total system}$$

As noted in the previous discussion, the shock stiffness is approximately 1.4 times the static stiffness. Thus,

$$K'_{\text{shock}} \cong (1.4)(836) = 1170 \text{ lb/in total}$$

This makes the shock natural frequency:

$$f_{\text{shock}} = 3.13 \sqrt{\frac{1170}{12}} = 31 \text{ Hz}$$

Thus, the calculation for the shock transmissibility becomes:

$$T_s \cong (4)(31)(0.011) = 1.4$$

Since this value is above 1.0, and the equation is only valid up to a value of 1.0, the information of Figure 20 must be used. Use of this graph indicates that the shock transmissibility will be approximately 1.22. Thus, the shock response will be:

$$G_o = T_s (g_i)$$

$$G_o = (1.22)(15) = 18.3g$$

From this response, the next step is to calculate the expected deflection when the selected isolator is subjected to the specified shock input. The equation of interest is:

$$d_{\text{shock}} = \frac{G_o}{(0.102)(f_n)^2}$$

$$d_{\text{shock}} = \frac{18.3}{(0.102)(31)^2} = 0.19 \text{ inch single amplitude}$$

The tentatively selected isolator, AM002-8, is capable of this much deflection without bottoming. Thus, the analysis proceeds to another operating condition.

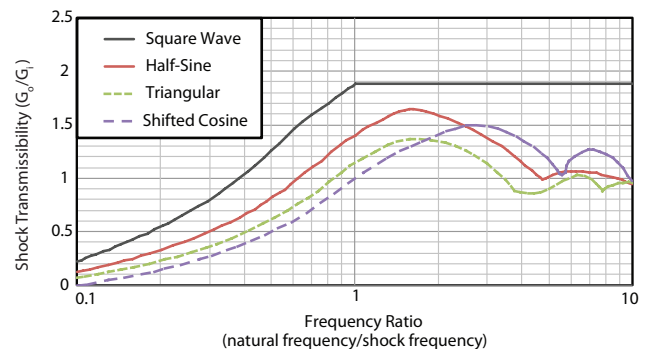

FIGURE 20 – SINGLE DEGREE-OF-FREEDOM SYSTEM RESPONSE TO VARIOUS SHOCK PULSES

Consider “Static” Loading Conditions

The static loading conditions in an isolator analysis are important from the standpoints of stress and deflection to which the isolator will be exposed. Such conditions are caused by the 1g load which the isolator must support as well as by any maneuver and/or steady-state accelerations, which may be imposed. In the present example, the static system stiffness was calculated as being 836 lb/in. The deflection of the system at any steady-state “g” loading may be calculated by using the equation:

$$d_{\text{static}} = \frac{(g_n)(W)}{K_{\text{static}}}$$

In the example, the sustained acceleration was specified as being 3g. Thus, the system deflection will be approximately:

$$d_{\text{static}} = \frac{(3)(12)}{836} = 0.043 \text{ inch}$$

VIBRATION & SHOCK THEORY

The selected isolator, AM002-8, is able to accommodate this deflection, even superimposed on the vibration conditions. Finally, none of the environmental conditions shown on the checklist will be of any concern. Thus, this appears to be an appropriate isolator selection. Of course, typical testing of this equipment, supported by the selected isolators, should be conducted to prove the suitability of this system.

The isolators presented in the product portion of this catalog will prove appropriate for many equipment installations. Should one of these products not be suitable, a custom design may be produced. LORD is particularly well equipped to provide engineering support for such opportunities. The following brief explanation will provide a rough sizing method for an isolator.

Estimating Isolator Size

There will be occasions when custom designs will be required for vibration and shock isolators. It should be remembered that schedule and economy are in favor of the use of the standard isolators shown in the product section here. These products should be used wherever possible. Where these will not suffice, LORD will assist by providing the design of a special mount. The guidelines presented here are to allow the packaging or equipment engineer to estimate the size of the isolator so that the equipment installation can be made with the thought in mind to allow space for the isolators and for the necessary deflection of the system as supported on them. The final isolator size may be slightly larger or smaller depending on the specifications being imposed.

Figure 21 shows a schematic of a conical isolator, such as may be used for protection of avionic equipment. The two most important parameters in estimating the size of such an isolator are the length of the elastomer wall, t_R , and the available load area. For purposes of simplification, a conical angle of 45° is used here. The ratio of axial to radial stiffness depends on this angle.

The elastomer wall length may be estimated based on the dynamic motion necessary for the requirements of the application. This length may be estimated through the following equation:

$$t_R = \frac{(X_i)(T_R)}{0.30}$$

Where: t_R = elastomer wall length (inches)
 X_i = resonant vibration input (inches *double amplitude*)
 T_R = resonant transmissibility

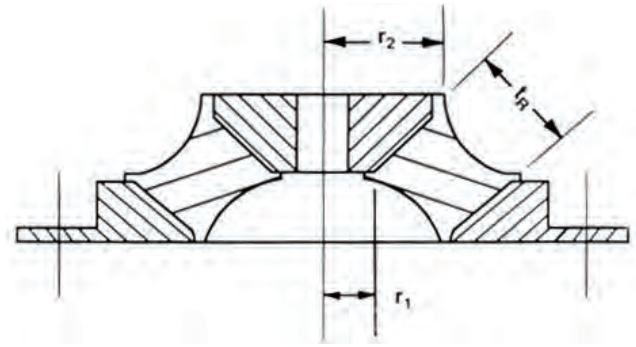

FIGURE 21 – ESTIMATING AVIONICS ISOLATOR SIZE

From the required natural frequency, the necessary dynamic spring rate is known from:

$$K' = \frac{(f_n)^2(W)}{9.8}$$

Where: K' = dynamic stiffness (lb/in)
 f_n = desired natural frequency (Hz)
 W = supported weight per isolator (lb)

For a conical type isolator, the dynamic spring rate/geometry relationship is:

$$K'_S = \frac{AG'}{t_R}$$

Where: K'_S = dynamic stiffness (lb/in)
 G' = dynamic modulus of the elastomer (psi)
 t_R = elastomer wall length (inches)

A (area term) is estimated as:

$$A \cong 1.4 \pi (r_2^2 - r_1^2)$$

This area term should be determined such that the dynamic stress at resonance is kept below approximately 40 psi.

$$\sigma = \frac{P}{A} \leq 40 \text{ psi}$$

and

$$P_{\max} \cong (g_i)(T_R)W$$

Where: σ = dynamic stress (lb/in²)
 P = applied force (lb)
 A = load area of the elastomer (in²)
 g_i = input 'g' level at resonance
 T_R = resonant transmissibility
 W = supported load per isolator (lb)

The combination of the elastomer wall length (t_R) and load area (A), estimated from the above, and the required attachment features will provide a good estimate of the size of the isolator required to perform the necessary isolation functions. The proper dynamic modulus is then selected for the isolator from an available range of approximately 90 to 250 psi at a 0.036 inch D.A., vibration input.

Resonant Dwells

The requirement of a “resonant dwell” of isolated equipment is becoming less common in today’s world. However, some projects still have such a requirement and it may be noted that many of the products described in the product sections have been exposed to resonant dwell conditions and have performed very well. Isolators designed to the elastomer wall and load area guidelines given above will survive resonant dwell tests without significant damage for systems with natural frequencies below approximately 65 Hz. Systems higher in natural frequency than this require special consideration and LORD engineers should be consulted.

Environmental Resistance

Many of the isolators shown in this catalog are inherently resistant to most of the environments (temperature, sand, dust, fungus, ozone, etc.) required by many specifications. The silicone elastomers are all in this category. One particularly critical area is fluid resistance where special oils, fuels or hydraulic fluids could possibly come in contact with the elastomer. LORD engineering should be contacted for an appropriate elastomer selection.

Testing of Vibration/Shock Isolators

LORD has excellent facilities for the testing of isolators. Electrodynamic shakers having up to eight thousand pound dynamic force capability are used to test many of the isolators designed or selected for customer use. These shakers are capable of sinusoidal and random vibration testing as well as sine-on-random and random-on-random conditions. These machines are also capable of many combinations of shock conditions and are supplemented with free-fall drop test machines. Numerous isolator qualification tests have been performed within the test facilities at LORD.

FURTHER THEORY

The preceding discussion presented general theory which is applicable to a broad class of vibration and shock problems. A special class of shock analysis is that which involves drop tests, or specifications, such as with protective shipping containers. This topic is treated in the following section.

SHIPPING CONTAINER ISOLATOR SELECTION

A special case of shock protection is found in the Shipping Container market. Here, the shock pulses are not defined as previously discussed but are specified in terms of being dropped from some height in a given configuration. Thus, the following discussion is presented.

The information here is presented to assist in the selection of LORD products to protect critical items in their shipping containers. It is intended that, for most applications, a mount from the line of standard LORD Shipping Container Mounts can be selected.

The basics of shock isolation are presented to give the reader an understanding of the effects of assumptions made during analysis of the system. The relationship of shock response to vibration response of the system as well as to the static stiffness characteristics of the mounts is discussed.

The variables which must be considered in the real world application of elastomeric shock mounts are presented. Included is a discussion of stiffness variation with strain and temperature and the effects of this variation on the overall response of the system.

Some basic equations are presented to allow calculation of system response in simple cases. For those instances where more elaborate analysis is required, a checklist of necessary information for a LORD analysis is provided.

Shock Isolation Theory

Although many factors can influence the dynamic response of a shipping container system, we may look at the overall problem as one of energy being imposed on the system. This energy must be stored, or dissipated. The energy stored in the mounts must then be released back to the system in a controlled manner such that the peak forces transmitted are below the critical level (fragility) for the mounted equipment.

With a given weight and geometry for the mounted equipment, the dynamic stiffness of the shock mounts is the adjustable factor at the designer's disposal to provide the desired protection. This stiffness determines the mounted system natural frequency that, in turn, controls the rate at which the energy is returned to the system and the maximum forces which will be imposed on the equipment.

VIBRATION & SHOCK THEORY

The energy input to the system enters over some time period (**pulse length τ**) and reaches some maximum force level (F_0). Schematically, this would appear as shown in Figure 22 on a force-time curve. The area enclosed under this curve is proportional to the energy.

If the shock mounts are selected correctly to protect the mounted equipment, the response through the mounts will be such that the energy (assuming no dissipation) will be transmitted to the mounted mass over a longer time period than that at which it entered the mounts. With this longer time period, the peak force will be lower than that imposed at the outside of the container. This is shown in Figure 23. Here, the energy is the same as that from Figure 22.

Conversely, if mounts are incorrectly selected, they could result in amplifying the peak forces seen by the mounted equipment. Figure 24 shows this case. Again, the energy is assumed equivalent to the original energy entering the container.

It should be noted that the situation of Figure 24 (shock amplification) can occur in a number of ways. Among these are:

- Incorrect mount stiffness
- Non-linear mount stiffness in the necessary deflection range
- Insufficient sway space available within the shipping container

Thus, it is important to accurately define system parameters, select appropriate shock mounts and design the shipping container with the mounting system in mind.

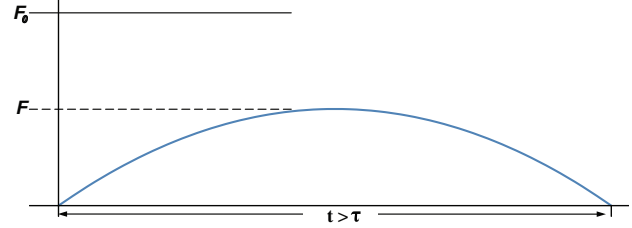

FIGURE 23 –
FORCE-TIME CURVE – RESPONSE THROUGH
SHOCK MOUNTS SHOCK REDUCTION

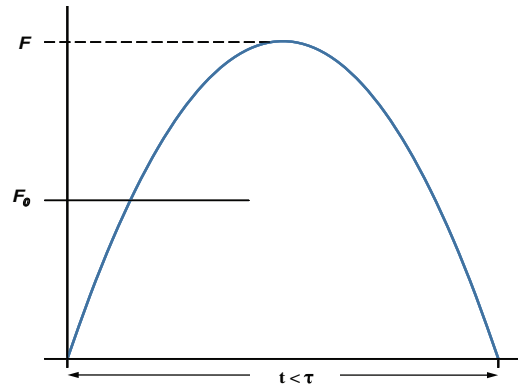

FIGURE 24 –
FORCE-TIME CURVE – RESPONSE THROUGH
SHOCK MOUNTS SHOCK AMPLIFICATION

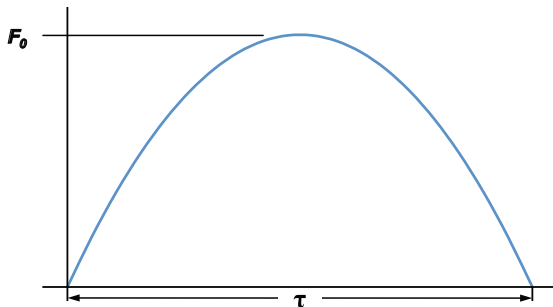

FIGURE 22 –
FORCE-TIME CURVE – INPUT TO CONTAINER

Basic Shock Equations — The basic equations for initial estimates of shock isolation systems are fairly simple. They involve the input to the system and the characteristics of the mounted mass and the shock mounts. In general, the shock to the system is modeled as an instantaneous velocity change for most shipping container applications.

We start the analysis knowing the impact velocity of the container into the barrier or floor. Typically, the velocity for a side or end impact is specified. For drop tests, this velocity must be calculated.

For a straight, vertical drop:

$$V_0 = \sqrt{2gh} \quad (1)$$

Where: V_0 = impact velocity (in/sec)
 g = acceleration due to gravity (386 in/sec²)
 h = drop height (in)

VIBRATION & SHOCK THEORY

The next necessary item to know is the system natural frequency:

$$f_n = 3.13 \sqrt{\frac{K'}{W}} \quad (2)$$

Where: f_n = system natural frequency (Hz)
 K' = system dynamic spring rate (lb/in)
 W = supported weight (lb)

Then the response acceleration may be calculated:

$$A_o = \frac{V_o f_n}{61.4} \quad (3)$$

Where: A_o = response acceleration (g)
 V_o = impact velocity (in/sec)
 f_n = system natural frequency (Hz)

as well as the deflection across the shock mounts:

$$d = \frac{9.8 A_o}{(f_n)^2} \quad (4)$$

Where: d = system deflection (inches)
 A_o = response acceleration (g)
 f_n = system natural frequency (Hz)

Of course, equation (3) may be solved in reverse if the equipment fragility is known and the system natural frequency is required.

$$f_n = \frac{A_o(61.4)}{V_o} \quad (5)$$

From this, we calculate the dynamic stiffness (spring rate) of the shock mounts required to provide the desired protection.

$$K' = \frac{(f_n)^2(W)}{9.8} \quad (6)$$

Where: K' = dynamic stiffness of mount(s) (lb/in)
 f_n = system natural frequency (Hz)
 W = supported weight (lb)

The above is the basic analysis conducted for the less involved shipping container applications. It is based on several assumptions:

- The support structure is infinitely rigid.
- There is no rebound of the container from the impact surface.
- There is no damping in the system.
- The mounted unit does not rotate.
- Shock mount stiffnesses are linear in the working range of deflection.

These same assumptions are carried through the remainder of this discussion. The first three tend in the direction of making the analysis conservative. The last assumption is one which must be watched closely based on mount size, shock levels and installation geometry.

Shipping Container Mount Descriptions

The great majority of elastomeric (rubber) shipping container mounts are of a “sandwich” type construction. That is, there are typically two flat plates, with threaded fasteners installed, which are bonded on either side of an elastomeric pad. The general construction is shown in Figure 25.

The shape of the mount can vary depending on the needs of a particular application. The standard product lines for LORD shipping container mounts are shown in the product section here.

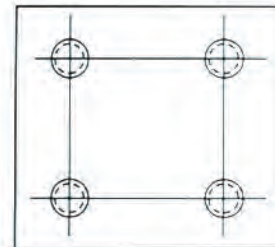
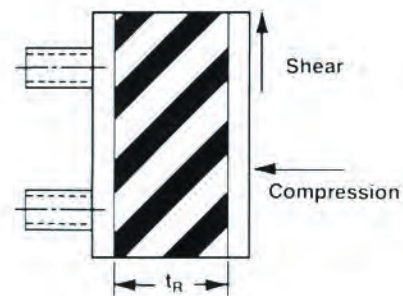

FIGURE 25 – TYPICAL SHIPPING CONTAINER MOUNT CONFIGURATION

VIBRATION & SHOCK THEORY

Shipping Container Mount Stiffness

As was shown in the previous section, the stiffness of the shipping container mount determines the dynamic response of the support system. This mount stiffness depends on the geometry of the mount and the properties of the elastomer. The general equation for the shear stiffness of an elastomeric sandwich mount is:

$$K_s = \frac{AG}{t_R} \quad (7)$$

Where: K_s = shear stiffness (lb/in)
 A = elastomer cross-sectional area (in²)
 G = elastomer shear modulus (psi)
 t_R = elastomer thickness (in)

The compression stiffness of a sandwich mount is higher than the shear stiffness by some value. This ratio of compression to shear stiffness is known as the "L" value for the mount, or:

$$L = \frac{K_C}{K_S} \quad (8)$$

Where: K_C = mount compression stiffness (lb/in)
 K_S = mount shear stiffness (lb/in)

The compression stiffness, like the shear stiffness, is dependent on geometry and elastomer properties. Here, the elastomer property of concern is the compression modulus. The complicating factor is that the *compression* modulus varies, in a nonlinear fashion, with the geometry of the mount. Figure 26 shows the general trend of the variation of compression modulus versus a geometry factor. The shape of this curve also varies with the basic hardness of the elastomer compound being used.

It is not the intent of this catalog to present mount design, but only application. Thus, let it suffice to say that, with the above background, there are specific ratios of compression to shear stiffness for various geometries for the mounts used in the shipping container industry. The "L" value is important to calculations of dynamic performance of a shipping container suspension.

The general relationship of the stiffness of the mounts, in various directions of loading, is shown schematically in the load versus deflection graph of Figure 27. It is important to note the range of linearity of the various curves. In shear, sandwich mounts can be linear up to deflections equal to 2.5 or 3.0 times the rubber thickness. In compression, this linear region may be only up to 0.25 times the rubber wall length. Shipping container mount systems assume linear stiffnesses of the mounts. Thus, care must be observed in interpreting results, particularly when compression loading of the mounts occurs.

NOTE: Mounting systems are not designed to load mounts in tension. Tension loading is to be avoided as much as possible.

In general, the best protection from shock is provided by using the mounts in a shear mode. This is not always practical nor possible as will be shown in the next section.

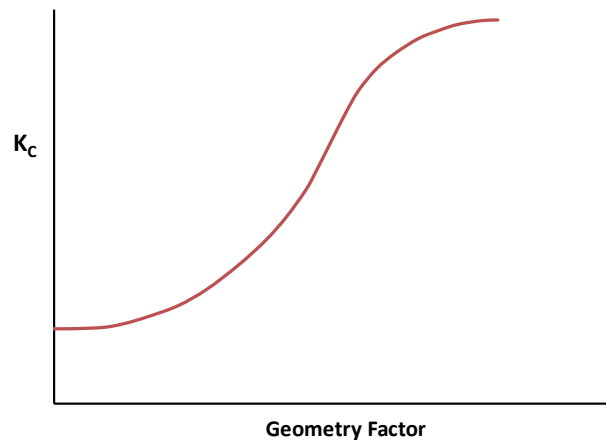

FIGURE 26 – VARIATION OF COMPRESSION MODULUS WITH GEOMETRY

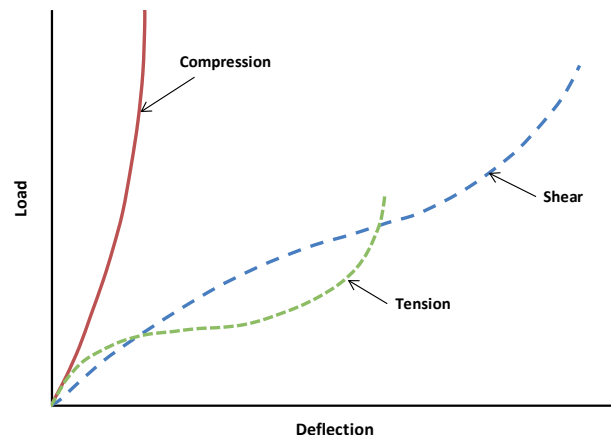

FIGURE 27 – RELATIONSHIP OF VARIOUS SANDWICH MOUNT STIFFNESSES

VIBRATION & SHOCK THEORY

System Installations

Depending on system requirements, shock mounts may be installed in shipping containers in a variety of configurations. Each type of installation has a distinct response characteristic. A key concept for analyzing any shipping container mounting system is that of “elastic center.”

The elastic center of a mounting system is that point in space about which the mounted equipment will rotate when subjected to an inertial load (acting through the center of gravity). The location of the elastic center of a mounting system depends on the orientation and spring rate characteristics of the mounts in the system. In most shipping container installations, the sandwich type mounts are used. This type of mount tends to project the elastic center approximately on a line extended from the compression axis. The actual point of projection depends on the “L” value of the mount being considered.

This may be demonstrated best by looking at some typical shipping container mount installations.

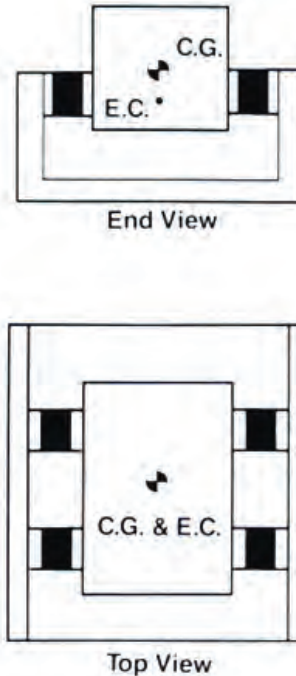

Where: E.C. = Elastic Center of Mounting System
C.G. = Center of Gravity of Mounted Equipment

Simple Shear System

The simple shear system is the easiest to analyze and understand. It has some advantages to the container manufacturer in simplicity of installation, but also has some disadvantages in performance, centering on the compression stiffness characteristics of the isolator.

The simple shear installation of shock mounts is shown in Figure 28.

In this system, the shock mounts react loads, in the vertical and fore-aft directions, through shearing of the elastomer. This is the softest direction of the mounts and will result in the lowest accelerations transmitted to the supported equipment. Loading in the lateral direction is absorbed in compression of the mounts and rotation about the elastic center (E.C.) of the system, as shown schematically in Figure 29. This type of response is typical of side impact tests. The rotation is the result of the inertial force imposed at the center of gravity (in a shock situation) which causes an overturning moment around the system elastic center.

FIGURE 28 –
SIMPLE SHEAR MOUNTING SYSTEM

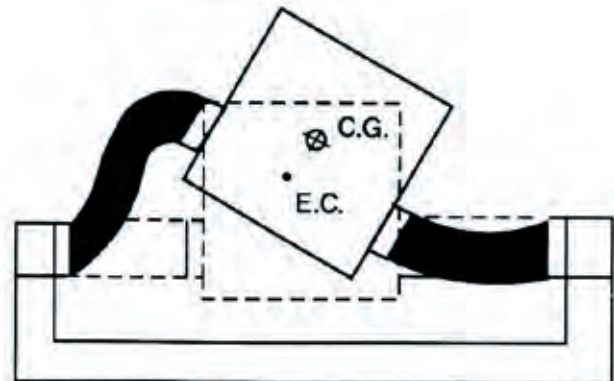

FIGURE 29 –
RESPONSE OF SHEAR SYSTEM TO
SIDE IMPACT (EXAGGERATED)

VIBRATION & SHOCK THEORY

Focalized Systems

In some container installations, the simple shear system results in unacceptably high transmitted shock loads in the lateral direction or in unacceptably high rotational deflections at the outer edges of the mounted equipment. In such cases, “focalized” systems are often used.

The shock mounts in such systems are “focused” at some angle such that the offset between the elastic center and the center-of-gravity is reduced. This reduced offset lessens the overturning moments due to side impacts and, thus, results in less rotation of the mounted equipment. The compromise with a focalized system is that the mounts are not being loaded in shear; neither in the vertical direction for a semi-focalized system, nor in any axis for a fully-focalized system. This situation leads to a combination of shear and compression loading which will result in a higher effective mount stiffness and higher ‘g’ loads in directions that were previously shear axes. Conversely, directions that were previously compression will have a lower stiffness and will result in lower ‘g’ loads.

Figures 30 and 31 show semi-focalized and fully-focalized systems, respectively. The semi-focalized installation has the mounts angled upward from the horizontal plane. This raises the elastic center of the mount system, increases the vertical system stiffness (due to the combination of compression and shear loading), but keeps the fore-aft axis completely in shear. The fully-focalized system places the mounts at angles up from the horizontal plane and inward toward the center of the mounted equipment. This arrangement results in combined shear and compression loading in all directions.

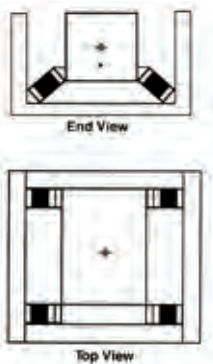

FIGURE 30 – SEMI-FOCALIZED SHIPPING CONTAINER MOUNT SYSTEM

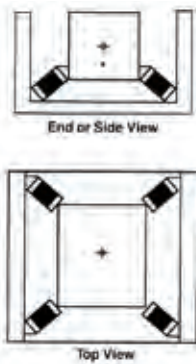

FIGURE 31 – FULL-FOCALIZED SHIPPING CONTAINER MOUNT SYSTEM

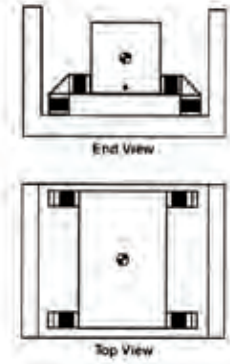

FIGURE 32 – GIMBALLED MOUNTING SYSTEM

Low Fragility

Some types of equipment are more fragile than others and require better protection in their shipping containers. If the required protection cannot be achieved through the use of any of the previously described mount systems, then something special must be done. There are two basic options. First, standard sandwich mounts may be used in a gimballed arrangement. Second, a special mount design may be conceived to provide low spring rates and high deflections in all directions.

The gimballed system is shown in Figure 32. This system will use more mounts and will require considerable space for mounts, but it does have the advantage of using available mount geometries. The special design option will be more compact but has the disadvantages of development time and lack of availability.

CAUTION: When analyzing low fragility systems, special consideration must be given to the system natural frequency. The system natural frequency must always be calculated and checked against various system requirements. One concern with low fragility systems is that they typically require very low natural frequencies and could fall into critical vibration frequency ranges for various methods of transportation (3 to 7 Hz). Thus, a low fragility mounting system may provide excellent shock protection but it will require significant sway space and could cause system natural frequencies to fall into critical ranges. Another concern here is the large static deflection imposed on the mounts. This can, over long periods, degrade performance. In cases where a low frequency system is indicated, the designer is encouraged to contact LORD.

VIBRATION & SHOCK THEORY

Properties of Elastomers

The “spring” portion of typical shipping container mountings is an elastomer (rubber) specially compounded and processed to provide certain stiffness characteristics. The standard line of LORD shipping container mountings uses a specially compounded synthetic elastomer which is called SPE® I. This material has high strength, medium damping and good low temperature flexibility – all of which are important to shipping container use.

Besides SPE I, other elastomers can be used but are less suited to the job at hand. For example, natural rubber has excellent strength but is not a good candidate where very low temperature performance or damping is required. Neoprene, another elastomer which has been used in some past shipping containers, is not recommended for low temperature applications.

A brief discussion of some of the properties of SPE I elastomer will give background in the behavior of elastomeric shock mountings.

Stiffness Versus Temperature

Figure 33 shows the trends of elastomer stiffness versus temperature for typical SPE I elastomer, Natural Rubber and Neoprene compounds. The data on which these curves are based was compiled using low amplitude motions across standard samples of the various elastomers. It is immediately obvious that the SPE I elastomer material is far superior to typical ranges of operation for shipping containers. This is the basic reason that LORD standardized on the SPE I elastomer for shipping container mounts.

Even more important is the fact that the variations in stiffness with temperature, as shown in Figure 33, must be taken into account when analyzing a shipping container installation. At low temperatures, the system natural frequencies and transmitted accelerations will be higher than at room temperature. At high temperatures, the natural frequencies and transmitted accelerations will be lower than at room temperature – provided there is enough space in the container for the system to deflect without bottoming.

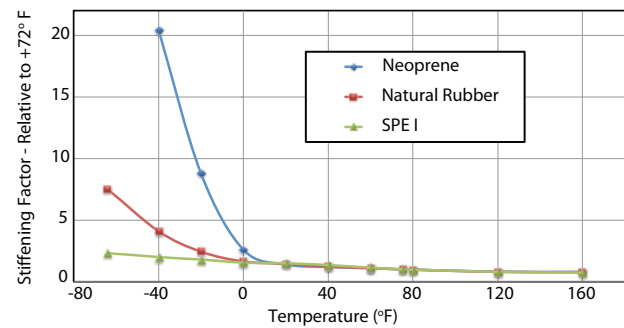

FIGURE 33 –
DYNAMIC STIFFNESS OF ELASTOMERS VS. TEMPERATURE

VIBRATION & SHOCK THEORY

Stiffness Versus Strain

Along with variations in stiffness with temperature, elastomers also exhibit different stiffnesses at different strain levels. At low strain levels, elastomers are stiffer than at high strain levels. Strain is defined as the deflection across the elastomer divided by the thickness of the elastomer.

The reason for this “strain sensitivity” of elastomers lies in the molecular structure of the material. Typically, the more complex the molecular structure, the higher the damping in the compound, the more pronounced the strain sensitivity will be.

The importance of this subject to the analysis of a shipping container suspension is that it must be recognized that an elastomeric shipping container mount will exhibit different stiffnesses when tested under different conditions. In general, under shock an elastomeric mount will be stiffer than when it is tested statically (with a slowly applied load). Further, an elastomeric mount will generally be stiffer still under most vibration tests than it is under shock conditions. As a rule of thumb, then it should be remembered that:

$$K_{vib} > K_{shock} > K_{static}$$

Where: **K** = spring rate (stiffness) of the part

Figure 34 shows the change in stiffness of a typical SPE I elastomer versus strain. Such a curve may be used to roughly estimate shock mount stiffness when the dynamic conditions imposed on the mounts are known.

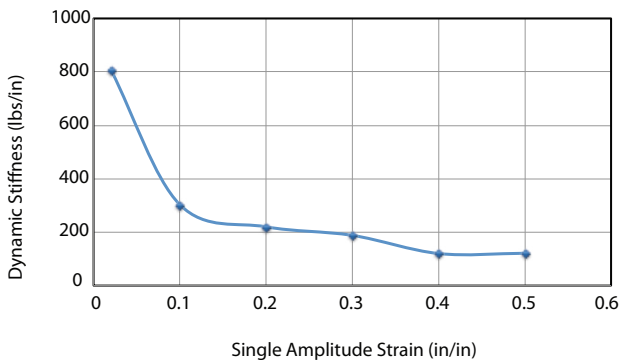

FIGURE 34 – STIFFNESS VS. STRAIN – TYPICAL SPE® I ELASTOMER

Drift

Elastomeric mounts under load will drift and increase their static deflection with time. This characteristic must be understood and taken into account when planning the amount of necessary sway space in a shipping container.

The total deflection to be planned for must include static deflection, dynamic motion and drift. This latter item will depend on the amount of load on the mount, the direction of the load and the temperature at which the mount is being loaded.

Due to the nature of the variables involved, it is difficult to generalize as to the drift characteristic. Some data is available which can be used as a guideline. A typical curve is shown in Figure 35.

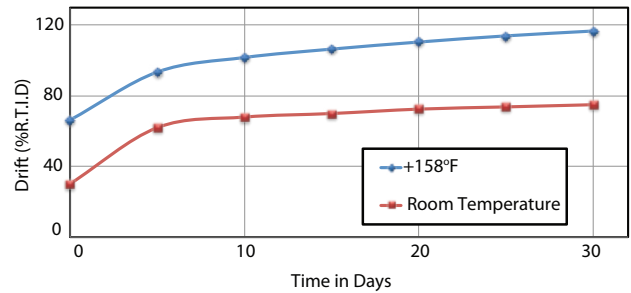

FIGURE 35 – TYPICAL DRIFT CURVE – SPE® I ELASTOMER (30 PSI)

Figure 35 shows room temperature and elevated temperature +158°F (+70°C) drift curves for a medium stiffness SPE I elastomer sample loaded at a static stress level of 30 psi. The shape of the curve is typical of elastomeric drift. The greatest percentage of drift occurs within the first 2 to 3 days after the load is applied. After that, the rate of drift slows asymptotically. Thus, some estimate of total drift can usually be made and included in calculations of necessary sway space.

The vertical axis of Figure 35 is in “Percent of Room Temperature Initial Deflection.” Thus, for example, if a system deflects 1.0 inch under its initial load at room temperature, it may be expected to deflect another 0.80 inch (approximately) after one month at room temperature, under a constant static load. This extra deflection must be allowed for in the internal sizing of the shipping container.

VIBRATION & SHOCK THEORY

SYSTEM ANALYSES

The following section gives a basic method for analyzing the most simple shipping container shock conditions. The following is based on several assumptions which must be kept in mind:

1. The properties of the shock mounts are assumed to be linear.
2. The container and mounted unit are inelastic (infinitely rigid).
3. The velocity change of the moving container is instantaneous upon impact.
4. All kinetic energy is stored in the mounts – no energy is dissipated.
5. The system is uncoupled in all directions for flat bottom and edgewise drops.
6. For a flat side drop, the effects of phase relationship between translational and rotational modes are neglected. They are assumed in phase, which covers the worst case.

As a rule of thumb for these simplified analyses, the effects of coupling are considered minimal if the eccentricity (e) of the center-of-gravity from the elastic center is one third, or less, of the shortest distance between mounts. This applies providing the unit is nearly symmetrical and homogeneous.

Refer to Symbols section for list of symbols as used in the following analyses.

Flat Bottom Drop Analysis

- 1) Calculate the maximum deflection required:

$$d = \frac{2h}{G_o - 2}$$

- 2) Calculate the drop energy:

$$\begin{aligned} PE &= Wh, \text{ when } d \leq 0.1h \\ PE &= W(h + d/2), \text{ when } d \geq 0.1h \\ \text{and } KE &= PE \end{aligned}$$

This energy must be stored in the mounts.

- 3) Calculate the system dynamic vertical spring rate:

$$K'_v = \frac{2(KE)}{d^2}$$

Where: $K'_v \cong K_v$ for natural rubber and neoprene

$K'_v \cong 1.3 K_v$ for SPE I elastomer

NOTE: These relationships are valid when strains are approximately 100% or greater.

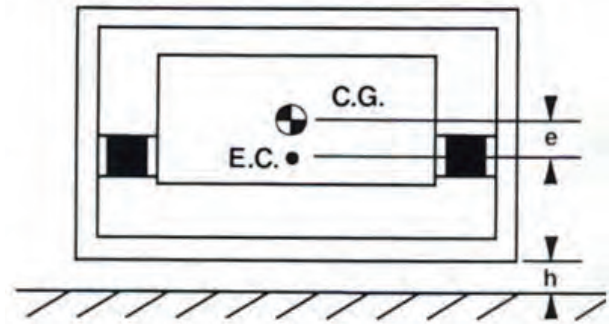

FIGURE 36 –
FLAT BOTTOM DROP

VIBRATION & SHOCK THEORY

Coupled Flat Side Drop Analysis

- 1) Calculate deflection required for linear uncoupled system:

$$d = \frac{2h}{G_o - 2}$$

- 2) Calculate drop energy:

$$PE = Wh, \text{ when } d < 0.1h$$

$$PE = W(h+d/2), \text{ when } d > 0.1h$$

NOTE: Using $d/2$ gives approximation of C.G. deflection of coupled system.

This energy must be stored in the mounts.

$$\text{Thus, } KE = PE$$

- 3) Calculate translational and static rotational deflection:

$$d_{\text{static}} = W/K'_v = \text{deflection at } 1g$$

$$d_{\text{Rstatic}} = We/K'_R$$

$$\text{Note: } K'_R = K'_H p^2$$

- 4) Total energy equation is: (1g condition)

$$KE_1 = \frac{K'_v d_{\text{static}}^2}{2} + \frac{K'_R d_{\text{Rstatic}}^2}{2}$$

or

$$KE_1 = \frac{W^2}{2K'_v} + \frac{W^2 e^2}{2K'_H p^2}$$

- 5) Total acceleration at C.G. is approximately:

$$G_{\text{CG}} \cong \sqrt{\frac{KE}{KE_1}}$$

- 6) G load calculated is for C.G. location only since moment equals weight times eccentricity (e) in the solution. Loads at points closer to E.C. than C.G. will be greater than G.

- 7) Calculate deflection:

a) **C.G. deflection** = $d + eG(d_{\text{Rstatic}})$

b) **Top deflection** = $d + cG(d_{\text{Rstatic}})$

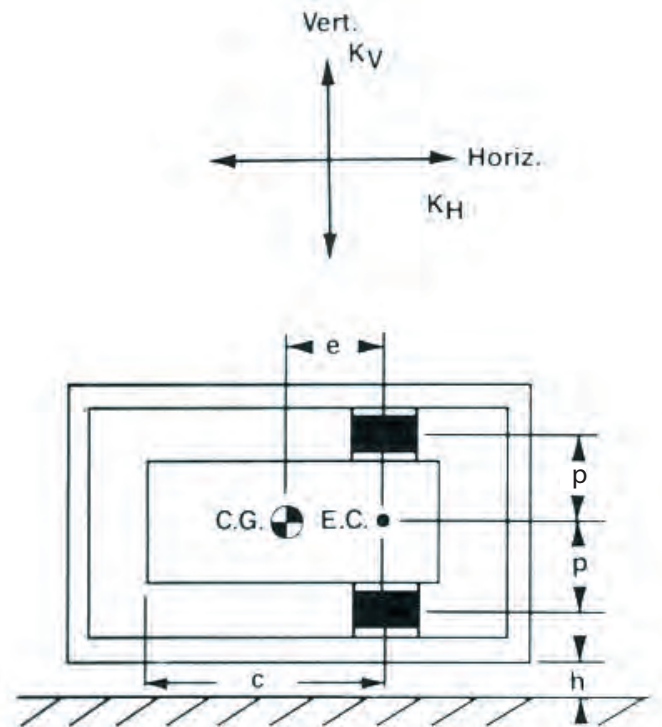

FIGURE 37 –
COUPLED FLAT SIDE DROP

VIBRATION & SHOCK THEORY

EDGEWISE ROTATIONAL END DROP ANALYSIS

A) General System Parameters

1) Calculate:

$$R = \sqrt{x^2 + y^2}$$

Where: R = distance from pivot point to C.G.
 x = horizontal distance from pivot point to C.G.
 y = vertical distance from pivot point to C.G.

2) Pitch moment about point P: $I_p = I_{CG} + MR^2$

Where: I_p = pitch moment of inertia (in-lb-sec²)
 I_{CG} = mass moment of inertia about C.G. (in-lb-sec²)
 M = mass of suspended unit (lb-sec²/in)

3) Radius of gyration about point P:

$$k = \sqrt{\frac{I_p}{M}}$$

4) Angles of Figure 38:

$$\theta_1 = 90^\circ - \phi - \sin^{-1}\left(\frac{h - h_1}{l}\right)$$

$$\theta_2 = 90^\circ - \phi - \sin^{-1}\left(\frac{h_1}{l}\right)$$

Where: θ_1 = angle between a line joining C.G. and pivot point (P) and vertical before drop
 θ_2 = angle between a line joining C.G. and pivot point (P) and vertical after drop
 $\phi = \tan^{-1}(y/x)$
 h = drop height (inches)
 h_1 = vertical distance of pivot point above floor (inches)
 l = length of container, overall (inches)

5) Angular velocity at impact:

$$\omega_o = \sqrt{\frac{2Rg(\cos\theta_1 - \cos\theta_2)}{k^2}}$$

Where: ω_o = angular velocity at impact (rad/sec)
 g = acceleration due to gravity (386 in/sec²)

6) Linear velocity of C.G. normal to container base at impact (t=0):

$$V = \omega_o R \cos(\phi)$$

Where: V = normal linear velocity of C.G. at impact (in/sec)

7) Linear velocity of unit end due to rotation about C.G., normal to container base at impact:

$$V_1 = \omega_o l_1$$

Where: V_1 = normal linear velocity of unit end due to rotation about C.G. (in/sec)
 l_1 = distance from C.G. to end of unit (inches)

8) To continue with analysis, the maximum vertical acceleration at C.G. of unit (B_1) and the maximum vertical acceleration at end of unit due to its rotation about C.G. (B_2) must be estimated based on the number of "G's" a unit can safely take (G_T).

Generally, a scalar sum of $B_1 + B_2$ is made equal to G_T . Then $B_1 + B_2 = 386 G_T$

For softer systems, i.e., $G_T = 10$ or less G's, it is desirable to maintain a ratio of $B_1 / B_2 = 1$ or $B_1 = B_2$

Therefore, $B_1 = 386 G_T / 2$ and $B_2 = 386 G_T / 2$

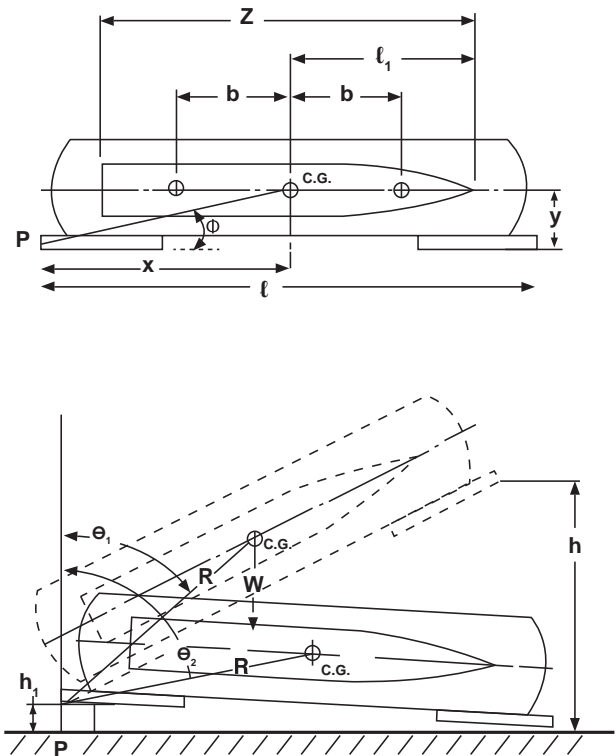

FIGURE 38 – EDGEWISE ROTATIONAL END DROP ANALYSIS

VIBRATION & SHOCK THEORY

B) System Response in Translation at Moment of Impact

1) Vertical translational circular frequency:

$$\omega_1 = B_1 / V$$

2) Vertical dynamic spring rate:

$$K'_V = \omega_1^2 M$$

C) System Response in Rotation

1) Rotational circular frequency about C.G.:

$$\omega_2 = B_2 / V_1$$

2) Rotational dynamic spring rate:

$$K'_R = (\omega_2)^2 I_{CG}$$

3) Mounting spacing:

$$b = \sqrt{\frac{K'_R}{K'_V}}$$

D) Total System Response

$$G_T(t) = \frac{B_1}{g} \sin(\omega_1 t) + \frac{B_2}{g} \sin(\omega_2 t)$$

$$d_T(t) = \frac{B_1}{(\omega_1)^2} \sin(\omega_1 t) + \frac{B_2}{(\omega_2)^2} \sin(\omega_2 t)$$

$$d_M(t) = \frac{B_1}{(\omega_1)^2} \sin(\omega_1 t) + \frac{b}{\ell_1} \frac{B_2}{(\omega_2)^2} \sin(\omega_2 t)$$

NOTE: If ω_1 and ω_2 are very close together then $\sin(\omega_1 t)$ and $\sin(\omega_2 t)$ will approach 1 at the same time t giving:

$$G_{Tmax} = \frac{B_1}{g} + \frac{B_2}{g}$$

$$d_{Tmax} = \frac{B_1}{(\omega_1)^2} + \frac{B_2}{(\omega_2)^2}$$

$$d_{Mmax} = \frac{B_1}{(\omega_1)^2} + \frac{b}{\ell_1} \frac{B_2}{(\omega_2)^2}$$

At this point overall balance and practical design of the system must be considered.

- Relationship of b to z and ℓ_1
- Comparison of ω_1 and ω_2 and B_1 and B_2 (well balanced system has $\omega_1 \cong \omega_2$ and $B_1 \cong B_2$ if possible)

E) Mounting Calculations

1) Mounting dynamic vertical spring rate:

$$K'_V = K'_S n$$

Where: n = number of equally loaded mounts

2) Mounting static vertical spring rate:

- a) $K'_V \cong K'_S$ for natural rubber and neoprene
 b) $K'_V \cong K'_S / 1.3$ for SPE I elastomer

NOTE: a) and b) are valid for strain values of 100% or greater.

3) Mounting is selected on the following basis:

- Static spring rate
- Deflection capability (linearity and strain)
- Shear area (stress)
- Fatigue
- Material (special properties, i.e., temperature, etc.)

F) Container Clearance

1) Total clearance is found by considering dynamic deflection, permanent set and safety factor

a) Total clearance for SPE I elastomer mountings

$$= d_T + \frac{d_T + 2}{8} + 0.5 \text{ in}$$

(0.5 in. is a maximum set normally encountered in SPE I mountings)

b) Total clearance for rubber or neoprene

$$= d_T + \frac{d_T + 2}{8}$$

NOTE: For temperature sensitive elastomer, total clearance should be based on high temperature performance.

VIBRATION & SHOCK THEORY

COMBINATION AND OBLIQUE DROPS

Cornerwise Rotational End Drop

Analyze same as edgewise rotational end drop.

Cornerwise Drop

Calculate same as flat drop. Be certain to avoid "pure" compression loading on mounts. Offset mounts from plane through C.G. and corner to induce rotation upon impact.

Incline Impact or Pendulum Impact

Analyze as flat side drop using drop height equal to vertical rise of C.G. about point of impact. The following formula may be used.

$$d = \frac{2h}{G_o} \text{ and } PE = Wh$$

Tip Over - Roll Over

Analyze as edgewise rotational drop for side to bottom or side to top and as equivalent flat side drop for bottom to side or top to side. (Cylindrical containers should be designed to include roll-over flanges – no analysis is applicable.)

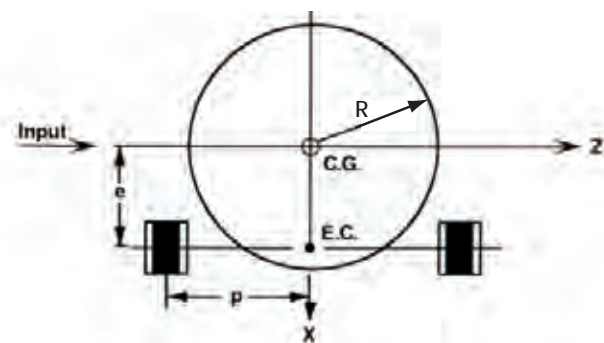

FIGURE 39 – CALCULATION OF COUPLED NATURAL FREQUENCIES

Coupled Systems

When the elastic center and center of gravity of a mounted system do not coincide, the system will, under dynamic excitation, exhibit combinations of translational and rotational modes. There are two ways of looking at this situation.

First, the system can be used as is and the rotational natural frequency calculated to determine if there is any reason for concern related to the dynamic environment to be encountered. Second, if it is determined that coupling, rotation, of the system cannot be tolerated, then the focalization angles for the mounts may be calculated to reduce or eliminate rocking of the mounted unit. The analyses of both of these cases depend on the geometry of the mounted system and the characteristics of the mounts.

The following calculations are for the above cases. Results in two coupled natural frequencies (f_n):

$$K'_R = K'_V p^2$$

$$S = \sqrt{K'_R / K'_H} = \sqrt{K'_V p^2 / K'_H}$$

$$\frac{f_c^2}{f_n^2} = \frac{1}{2} \left(1 + \frac{S^2}{R^2} + \frac{e^2}{R^2} \right) \pm \sqrt{\frac{1}{4} \left(1 + \frac{S^2}{R^2} + \frac{e^2}{R^2} \right)^2 - \frac{S^2}{R^2}}$$

NOTE: For fore and aft input, use b (1/2 mount spread, Figure 38) in place of p , fore and aft spring rate in place of K'_H , and pitch radius of gyration.

L value – Ratio of Compression to Shear Spring Rate:

$$K'_V = 4K'_S [L \cos^2 \beta + \sin^2 \beta]$$

$$K'_H = 4K'_S [L \cos^2 \alpha + \sin^2 \alpha]$$

NOTE: Above analysis assumes system uses four mounts.

VIBRATION & SHOCK THEORY

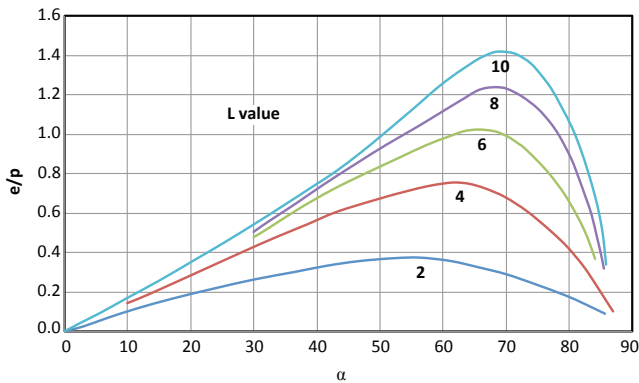
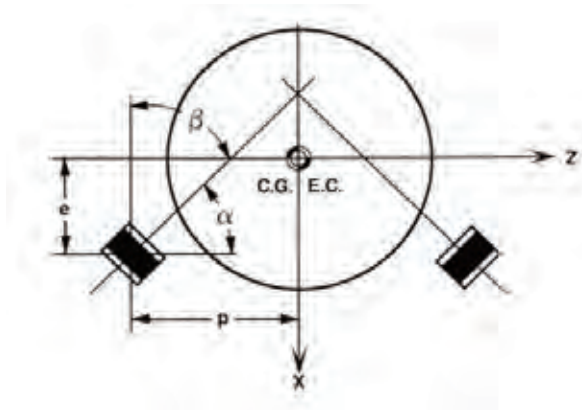

FIGURE 40 –
CALCULATION OF FOCALIZATION ANGLE TO
PROJECT ELASTIC CENTER TO POINT OF C.G.
TO UNCOUPLE SYSTEM

Vibration Testing

The preceding analyses have been focused on shock (drop) testing of shipping containers. Most shipping containers must also be exposed to some vibration testing and a review of critical frequencies should be made.

The key here is to recognize that the stiffness of an elastomeric isolator will typically be higher during vibration testing than during a shock or static test. The amount of stiffening depends on the magnitude of the vibration, which translates into strain across the elastomer.

The strain, during a vibration test may be calculated roughly as:

$$\varepsilon = \left(\frac{X_i}{2}\right)(T_R) / t_R$$

Where: ε = strain (in/in)
 X_i = double amplitude input vibration level (in)
 T_R = resonant transmissibility (assume 5 for SPE® I elastomer)
 t_R = thickness of elastomer (in)

Once the dynamic strain is calculated, Figure 34 may be used to estimate the dynamic stiffness versus the static stiffness of the mount. Then, the system natural frequencies may be calculated using the analysis previously presented.

If a resonant dwell vibration test is to be conducted, it is normal to run the test intermittently to avoid overheating the elastomeric mounts due to hysteretic heating. The surface temperature of the mount should not be allowed to exceed +115°F (+46°C).

Mount Selection

Once the dynamic analyses are completed and the required mount stiffness is known, the appropriate mount may be selected. This selection will be based on stiffness, maximum stress and maximum strain.

The following guidelines are applicable to LORD SPE I elastomer shock mounts:

- Maximum dynamic stress should be limited to 225 psi or less. The analysis of the most severe shock at the lowest operational temperature will result in the highest dynamic load.
- Maximum static 1g stress should be limited to 25 psi or less.
- Maximum dynamic strain should be 250%. The analysis of the most severe shock at the *highest* operational temperature will result in the highest dynamic strain.

Standard Mounts

The product section contains the standard sizes of shipping container mounts manufactured by LORD using SPE I elastomer. Wherever possible, these mounts should be used. They were selected based on years of usage data for many shipping container applications.

VIBRATION & SHOCK THEORY

DATA REQUIRED FOR SHIPPING CONTAINER ANALYSES

As with any engineering problem, the quality and accuracy of the calculated solution is only as good as the information provided as input to the analysis. A Shipping Container Suspension System Questionnaire is available to outline the minimum data needed for a reasonable shipping container analysis. This questionnaire, found in this catalog, can be used as a check list for self-analysis or for transmittal to LORD for a formal system analysis.

STANDARD SHIPPING CONTAINER SHOCK TESTS

No matter what mode of transportation is used, shock represents the most serious threat to equipment reliability. The standard tests described here are intended to simulate the worst shock conditions that would be expected for shipping/handling environments. Selected tests from those shown here are included in packaging specifications and used for designing shipping container suspension systems.

The letter "h" in the diagrams depicts the drop height specified in the applicable packaging specification. Exceptions: in Test 7 and 11 an impact velocity will be specified; in Test 9 and 10 neither drop height nor velocity is specified.

Flat Drop – Test 1

Container shall be raised the specified vertical distance and allowed to fall freely to a concrete or similarly hard surface so that container strikes flat on the skids or surface involved.

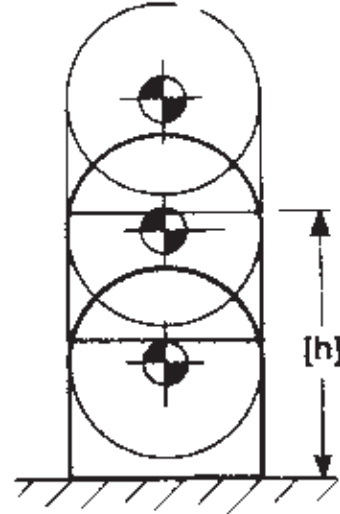

TEST 1 – FLAT DROP

Corner Drop – Test 2

Container shall be raised the specified vertical distance such that the container is suspended with the center-of-gravity vertically above the striking corner. Container shall be allowed to fall freely to a concrete or similarly hard surface, striking corner first. Cylindrical containers shall be dropped on each quarter or corner.

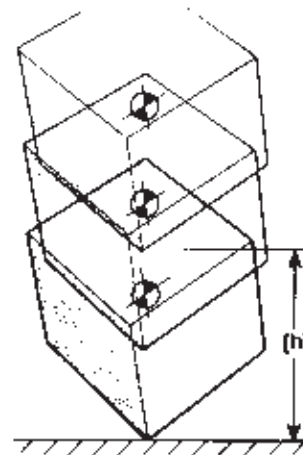

TEST 2 – CORNER DROP

VIBRATION & SHOCK THEORY

Corner Drop (Special) – Test 3

Container shall be raised the specified vertical distance so that it will strike at the greatest angle possible, still ensuring that the container will come to rest on its base. The test shall be repeated for each of the corners or quarters.

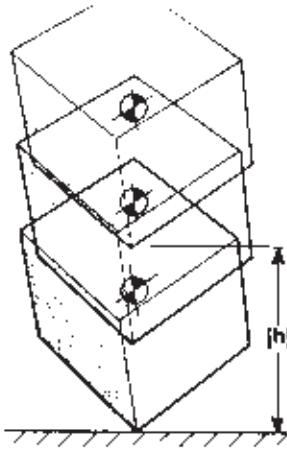

TEST 3 – CORNER DROP (SPECIAL)

Edgewise Rotational Drop – Test 5

Container shall be supported at one end of the base on a sill or block of specified height and at right angles to skids. The opposite end shall be raised to the specified vertical height and allowed to fall freely onto a concrete or similarly hard surface. If container size and center-of-gravity location prevent dropping from prescribed height, the greatest attainable height shall be the height of the drops.

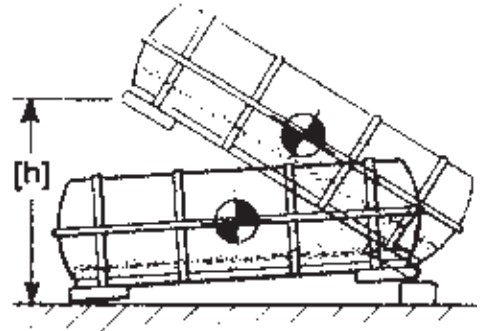

TEST 5 – EDGEWISE ROTATIONAL DROP

Edge Drop – Test 4

Container shall be raised the specified vertical distance, such that the container is suspended with the center-of-gravity vertically above the striking edge. The container shall be allowed to fall freely to a concrete or similarly hard surface, striking edge first.

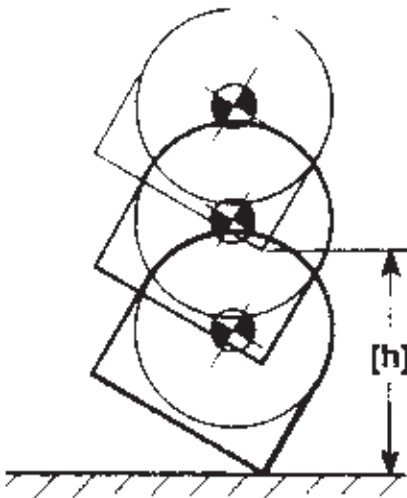

TEST 4 – EDGE DROP

Cornerwise Rotational Drop – Test 6

Container shall be supported at one corner of its base on a low sill or block of specified height. The other corner of the same end shall be supported by a higher sill or block. The lowest point of the opposite end shall be raised to the specified vertical height and allowed to fall freely onto a concrete or similarly hard surface. If container size and center-of-gravity location prevent dropping from prescribed height, the greatest attainable height shall be the height of the drops.

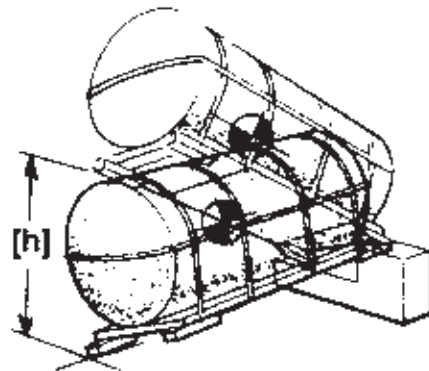

TEST 6 – CORNERWISE ROTATIONAL DROP

VIBRATION & SHOCK THEORY

Inclined Impact – Test 7

Test shall be in accordance with ASTM Standard Method D880, "The Inclined Impact Test for Shipping Containers," suitably modified to accommodate the container. Velocity at impact shall be as specified. The Pendulum Impact may be used in lieu of this test, and vice versa.

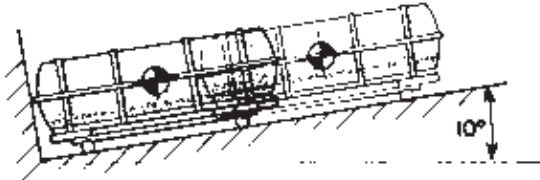

TEST 7 – INCLINED IMPACT

Rollover Test – Test 10

Container, erect on its base, shall be tipped sideways until it falls freely and solely of its own weight to a concrete or similarly hard surface. This shall be repeated with falls from the side to top, from top to the other side, and from other side to the base, thus completing one revolution.

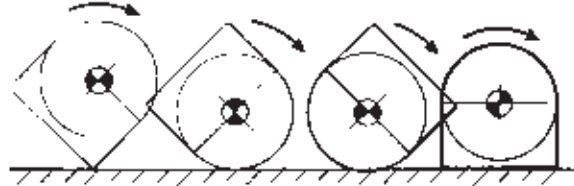

TEST 10 – ROLLOVER TEST

Pendulum Impact – Test 8

Container shall be suspended by four or more ropes or cables 16 feet or more long. Container shall be pulled back so that the center-of-gravity has been raised the specified distance. Container shall be released, allowing the end surface or skid, whichever extends further, to strike on an unyielding barrier of concrete or similarly hard material that is perpendicular to the container at impact.

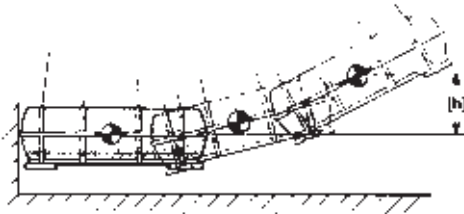

TEST 8 – PENDULUM IMPACT

Rolling Impact Test (Cylindrical Containers) – Test 11

Container shall be allowed to roll down an incline on its rolling flanges and shall strike a vertical, rigid, flat surface at a specified velocity.

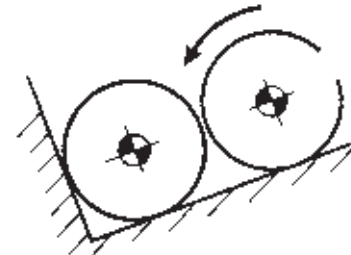

TEST 11 – ROLLING IMPACT TEST
(CYLINDRICAL CONTAINERS)

Tip Over Test – Test 9

Container, erect on its base, shall be slowly tipped (in the direction specified) until it falls freely and solely by its own weight to a concrete or similarly hard floor.

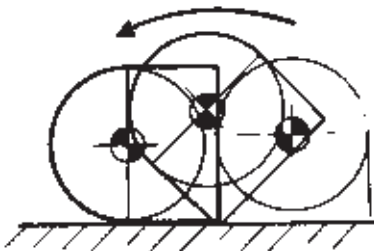

TEST 9 – TIP OVER TEST

LOW PROFILE AVIONICS MOUNTS

AM SERIES

LOW PROFILE
AVIONICS
MOUNTS

LOW PROFILE AVIONICS MOUNTS

AM SERIES

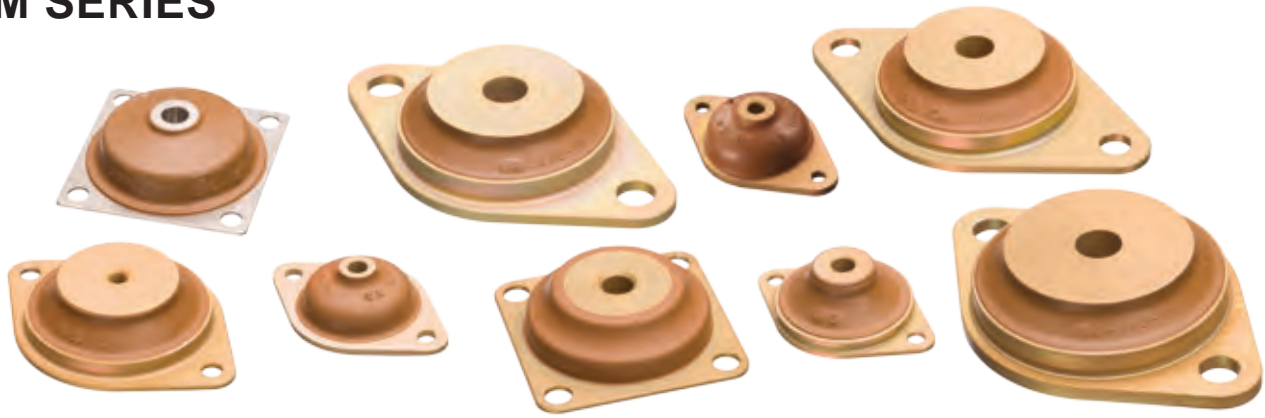

LOW PROFILE, ALL-DIRECTION VIBRATION AND SHOCK MOUNTS FOR AVIONICS EQUIPMENT AND OTHER SENSITIVE DEVICES

LORD Corporation Low Profile Avionics Mounts (AM Series) set the standard for compact, high-load, high-capacity isolators. They are designed to support and protect avionics equipment in all types of aircraft. Inertial guidance and navigation systems and radar components are examples of applications where these mounts are used. In addition, AM Series Mounts are used to isolate engine/aircraft accessories such as fuel controls, pressure sensors and oil coolers.

The Low Profile Avionics Mounts are tested and approved to the environmental tests appearing in MIL-STD-810 or MIL-E-5400. Tables show the sizes, capacities and the spring rates of these vibration isolators. They may be used in a temperature range of -65°F to +300°F (-54°C to +149°C) for BTR® Silicone and -40°F to +300°F (-40°C to +149°C) for BTR® II Silicone.

Low Profile Avionics Mounts are made with specially compounded silicone elastomers which exhibit excellent resonant control. This is evidenced by the low transmissibility at resonance. These designs also provide linear deflection characteristics.

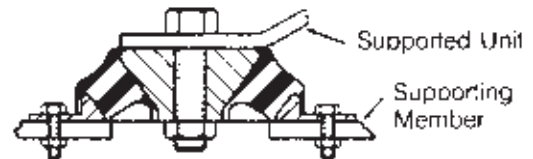

FIGURE 1 – TYPICAL INSTALLATION OF AM SERIES MOUNT*

* Requires small attachment holes and a large clearance hole for the through bolt and nut. The clearance hole diameter should be equal to the nut width (across corners) + $T_{R,x}$ (max. D.A. input at resonance).

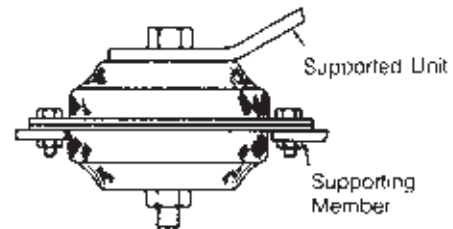

FIGURE 2 – TYPICAL INSTALLATION OF BACK-TO-BACK MOUNT**

** When the load per support point exceeds the load rating of a single mount, the mounts can be installed back-to-back thereby doubling the capacity and the spring rate.

LOW PROFILE AVIONICS MOUNTS

AM-001 SERIES



- **Maximum static load per mount:**
3 lb (1.4 kg)
- **Maximum dynamic input at resonance:**
0.036 in (0.91 mm) D.A.
- **Weight:**
0.21 oz (6.0 g)

- **Materials:**
Metal parts and finish – aluminum alloy, chromate treated per MIL-DTL-5541, Class 1A
Inner member – 2024-T4 aluminum
Plate – 2024-T3 aluminum
Elastomer – LORD BTR® or BTR® II Silicone

FIGURE 1 – PART DIMENSIONS

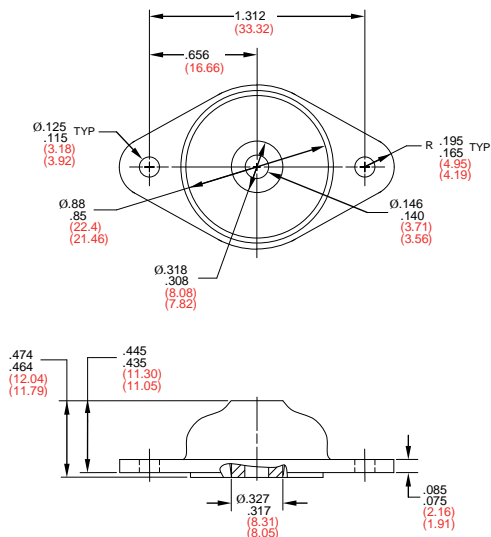

Metric values in parenthesis.

TABLE 1 – PERFORMANCE CHARACTERISTICS

Part Number	Axial Natural Frequency* - f_n (Hz)	Dynamic Axial Spring Rate		Dynamic Radial Spring Rate	
		lb/in	N/mm	lb/in	N/mm
BTR®					
AM-001-2	17	89	16	74	13
AM-001-3	19	104	18	87	15
AM-001-4	20	122	21	102	18
AM-001-5	22	143	25	119	21
AM-001-6	23	164	29	137	24
AM-001-7	25	187	33	156	27
AM-001-8	27	215	38	179	31
AM-001-9	29	247	43	206	36
AM-001-10	31	284	50	237	41
BTR® II					
AM-001-17	15	68	12	57	10
AM-001-18	17	90	16	75	13
AM-001-19	20	117	20	98	17
AM-001-20	22	146	26	122	21
AM-001-21	25	195	34	163	28

* At 0.036 in (0.91 mm) D.A. input and maximum static load.

To correct for loads below rated loads, use:

$$f_n = f_{nn} \sqrt{P_R / P_A}$$

where:

f_n = natural frequency at actual load

f_{nn} = nominal natural frequency

P_A = actual load

P_R = rated load

FIGURE 2 – TRANSMISSIBILITY VS. FREQUENCY

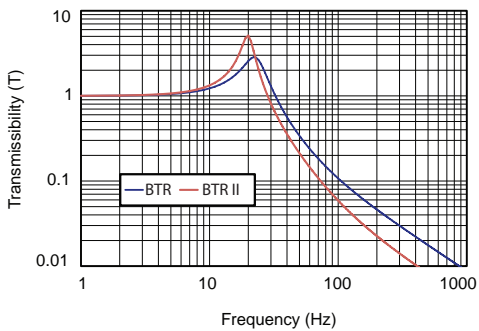
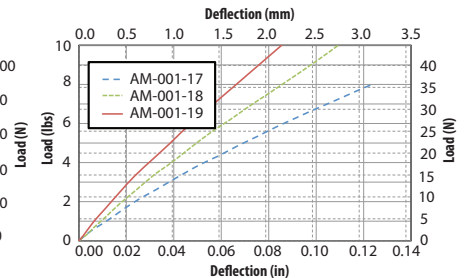
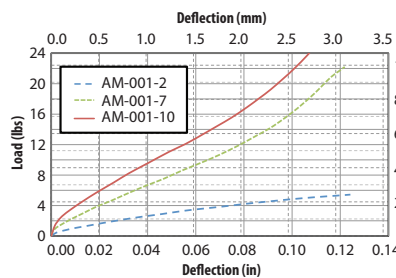

FIGURE 3 – TYPICAL LOAD VS. DEFLECTION VALUES

BTR ON AM-001 SERIES

BTR II ON AM-001 SERIES



LOW PROFILE AVIONICS MOUNTS

AM-002 SERIES



- **Maximum static load per mount:**
3.5 lb (1.6 kg)
- **Maximum dynamic input at resonance:**
0.060 in (1.52 mm) D.A.
- **Weight:**
0.27 oz (7.7 g)

- **Materials:**
Metal parts and finish – aluminum alloy, chromate treated per MIL-DTL-5541, Class 1A
Inner member – 2024-T315 or 2024-T4 aluminum
Plate – 2024-T315 or 2024-T4 aluminum
Elastomer – LORD BTR® or BTR® II Silicone

TABLE 1 – PERFORMANCE CHARACTERISTICS

Part Number	Axial Natural Frequency* - f_n (Hz)	Dynamic Axial Spring Rate		Dynamic Radial Spring Rate	
		lb/in	N/mm	lb/in	N/mm
BTR®					
AM-002-2	14	71	12	71	12
AM-002-3	15	84	15	84	15
AM-002-4	17	98	17	98	17
AM-002-5	18	114	20	114	20
AM-002-6	19	131	23	131	23
AM-002-7	20	150	26	150	26
AM-002-8	22	173	30	173	30
AM-002-9	23	197	35	197	35
AM-002-10	25	226	40	226	40
BTR® II					
AM-002-11	13	63	11	63	11
AM-002-12	15	82	14	82	14
AM-002-13	17	107	19	107	19
AM-002-14	19	134	23	134	23
AM-002-15	22	179	31	179	31

* At 0.036 in (0.91 mm) D.A. input and maximum static load.

To correct for loads below rated loads, use:

$$f_n = f_{nn} \sqrt{P_R / P_A}$$

where:

- f_n = natural frequency at actual load
- f_{nn} = nominal natural frequency
- P_A = actual load
- P_R = rated load

FIGURE 1 – PART DIMENSIONS

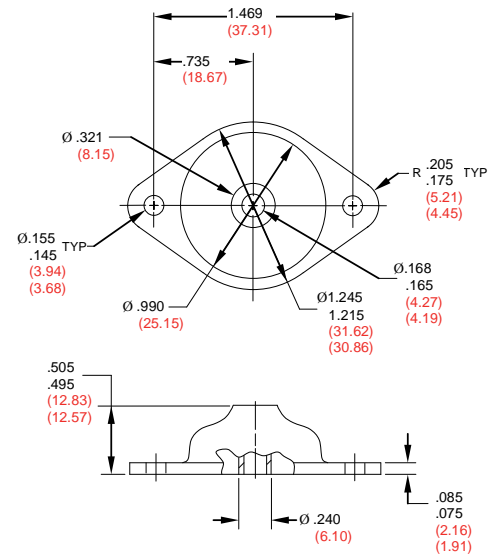

Metric values in parenthesis.

FIGURE 3 – TYPICAL LOAD VS. DEFLECTION VALUES

BTR ON AM-002 SERIES

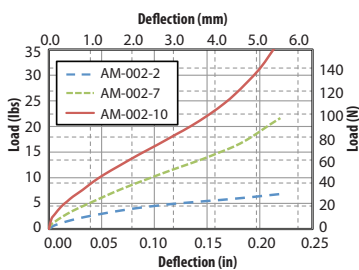

BTR II ON AM-002 SERIES

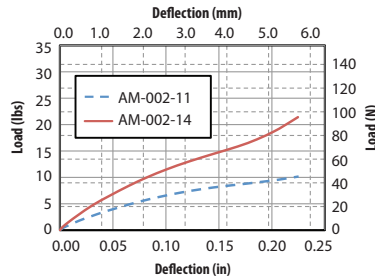
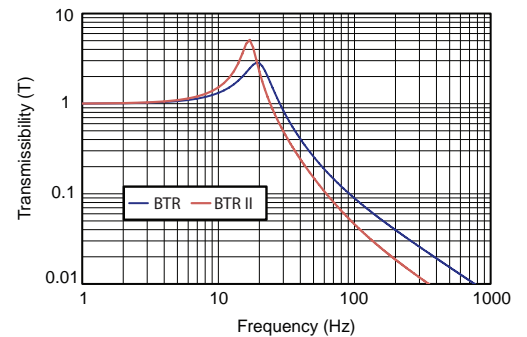

FIGURE 2 – TRANSMISSIBILITY VS. FREQUENCY



LOW PROFILE AVIONICS MOUNTS

AM-003 SERIES



- **Maximum static load per mount:**
4.5 lb (2.0 kg)
- **Maximum dynamic input at resonance:**
0.036 in (0.91 mm) D.A.
- **Weight:**
0.34 oz (9.6 g)

- **Materials:**
Metal parts and finish – aluminum alloy, chromate treated per MIL-DTL-5541, Class 1A
Inner member – 2024-T4 aluminum
Plate – 2024-T315 aluminum
Elastomer – LORD BTR® or BTR® II Silicone

FIGURE 1 – PART DIMENSIONS

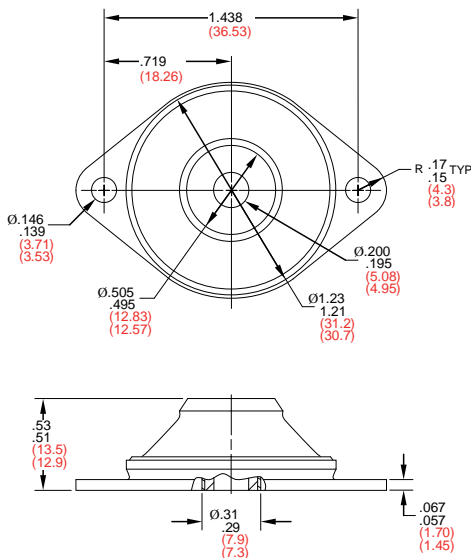

Metric values in parenthesis.

FIGURE 2 – TRANSMISSIBILITY VS. FREQUENCY

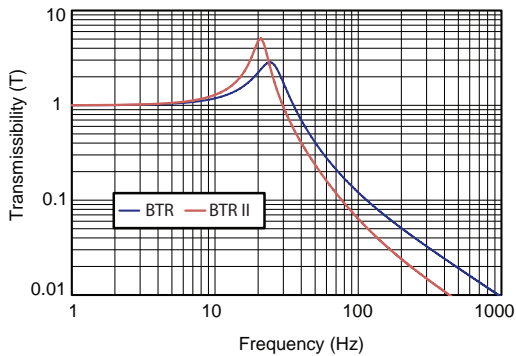

TABLE 1 – PERFORMANCE CHARACTERISTICS

Part Number	Axial Natural Frequency* - f_n (Hz)	Dynamic Axial Spring Rate		Dynamic Radial Spring Rate	
		lb/in	N/mm	lb/in	N/mm
BTR®					
AM-003-2	18	152	27	169	30
AM-003-3	20	178	31	198	35
AM-003-4	21	209	37	232	41
AM-003-5	23	244	43	271	47
AM-003-6	25	278	49	309	54
AM-003-7	26	319	56	354	62
AM-003-8	28	367	64	408	71
AM-003-9	30	421	74	468	82
AM-003-10	33	482	84	536	94
BTR® II					
AM003-11	16	117	20	130	23
AM003-12	18	153	27	170	30
AM003-13	21	200	35	222	39
AM003-14	23	251	44	279	49
AM003-15	27	333	58	370	65

* At 0.036 in (0.91 mm) D.A. input and maximum static load.

To correct for loads below rated loads, use:

$$f_n = f_{nm} \sqrt{P_R/P_A}$$

where:

f_n = natural frequency at actual load

f_{nm} = nominal natural frequency

P_A = actual load

P_R = rated load

FIGURE 3 – TYPICAL LOAD VS. DEFLECTION VALUES

BTR ON AM-003 SERIES

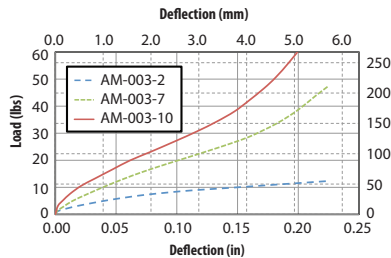

BTR II ON AM-003 SERIES

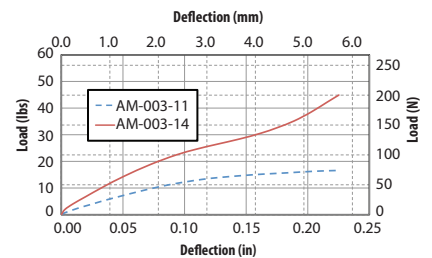

LOW PROFILE AVIONICS MOUNTS

AM-004 SERIES



- **Maximum static load per mount:**
4 lb (1.8 kg)
- **Maximum dynamic input at resonance:**
0.10 in (2.54 mm) D.A.
- **Weight:**
0.46 oz (13.0 g)

- **Materials:**
Metal parts and finish – stainless steel, passivated
Inner member – 304 stainless steel
Plate – 301 stainless steel annealed
Elastomer – LORD BTR® or BTR® II Silicone

TABLE 1 – PERFORMANCE CHARACTERISTICS

Part Number	Axial Natural Frequency* - f_n (Hz)	Dynamic Axial Spring Rate		Dynamic Radial Spring Rate	
		lb/in	N/mm	lb/in	N/mm
BTR®					
AM-004-2	13	71	12	79	14
AM-004-3	14	84	15	93	16
AM-004-4	15	98	17	109	19
AM-004-5	17	114	20	127	22
AM-004-6	18	131	23	146	25
AM-004-7	19	150	26	167	29
AM-004-8	21	173	30	192	34
AM-004-9	22	197	35	219	38
AM-004-10	23	226	40	251	44
BTR® II					
AM-004-14	12	61	11	68	12
AM-004-15	14	80	14	89	16
AM-004-16	16	104	18	116	20
AM-004-17	18	130	23	144	25
AM-004-18	21	173	30	192	34

* At 0.036 in (0.91 mm) D.A. input and maximum static load.

To correct for loads below rated loads, use:

$$f_n = f_{nm} \sqrt{P_R / P_A}$$

where:

- f_n = natural frequency at actual load
- f_{nm} = nominal natural frequency
- P_A = actual load
- P_R = rated load

FIGURE 3 – TYPICAL LOAD VS. DEFLECTION VALUES

BTR ON AM-004 SERIES

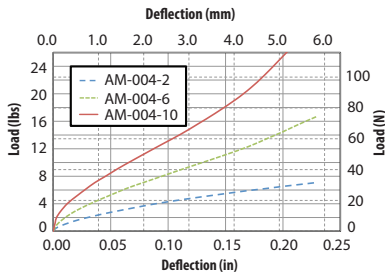

BTR II ON AM-004 SERIES

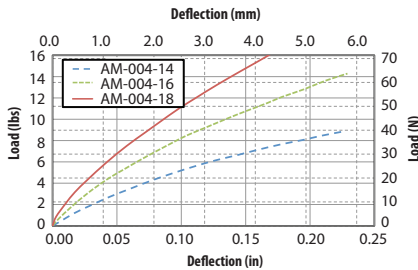
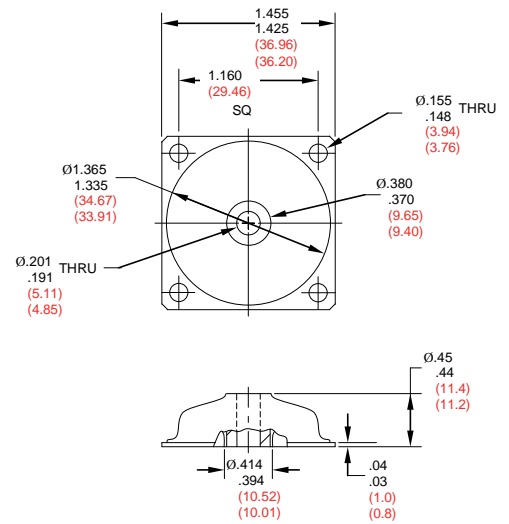
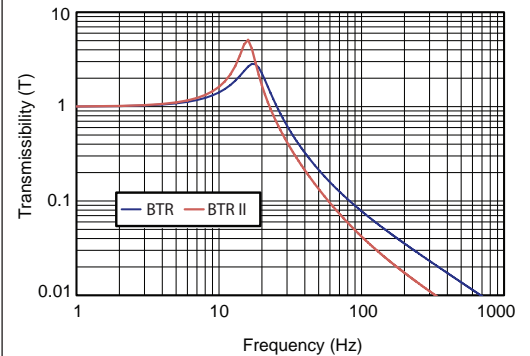

FIGURE 1 – PART DIMENSIONS



Metric values in parenthesis.

FIGURE 2 – TRANSMISSIBILITY VS. FREQUENCY



LOW PROFILE AVIONICS MOUNTS

AM-005 SERIES



- **Maximum static load per mount:**
6 lb (2.7 kg)
- **Maximum dynamic input at resonance:**
0.036 in (0.91 mm) D.A.
- **Weight:**
0.67 oz (19.0 g)

• **Materials:**

Metal parts and finish – aluminum alloy, chromate treated per MIL-DTL-5541, Class 1A
 Inner member – 2024-T315 or 2024-T4 aluminum
 Plate – 2024-T315 or 2024-T4 aluminum
 Elastomer – LORD BTR® or BTR® II Silicone

FIGURE 1 – PART DIMENSIONS

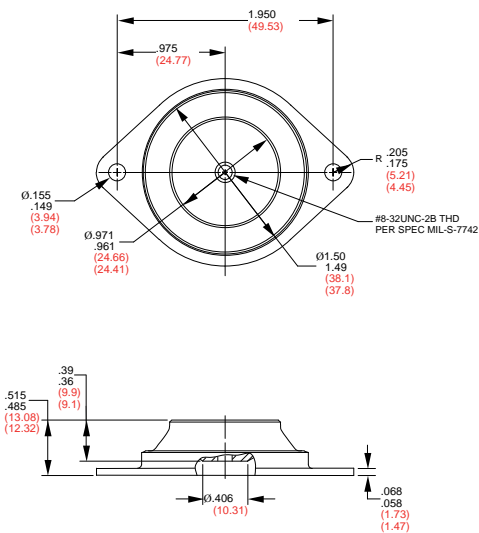

Metric values in parenthesis.

TABLE 1 – PERFORMANCE CHARACTERISTICS

Part Number	Axial Natural Frequency* - f_n (Hz)	Dynamic Axial Spring Rate		Dynamic Radial Spring Rate	
		lb/in	N/mm	lb/in	N/mm
BTR®					
AM-005-2	24	353	62	272	48
AM-005-3	26	414	73	318	56
AM-005-4	28	485	85	373	65
AM-005-5	31	566	99	435	76
AM-005-6	33	647	113	498	87
AM-005-7	35	743	130	572	100
AM-005-8	37	854	150	657	115
AM-005-9	40	979	171	753	132
AM-005-10	43	1121	196	862	151
BTR® II					
AM-005-11	26	426	75	328	57
AM-005-12	30	557	98	428	75
AM-005-13	35	726	127	558	98
AM-005-14	39	905	158	696	122
AM-005-15	45	1210	212	931	163

* At 0.036 in (0.91 mm) D.A. input and maximum static load.

To correct for loads below rated loads, use:

$$f_n = f_{nn} \sqrt{P_R/P_A}$$

where:

f_n = natural frequency at actual load

f_{nn} = nominal natural frequency

P_A = actual load

P_R = rated load

FIGURE 2 – TRANSMISSIBILITY VS. FREQUENCY

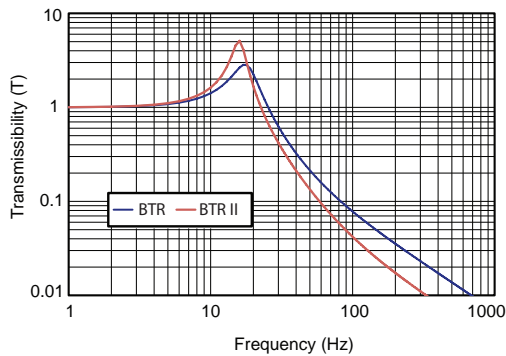
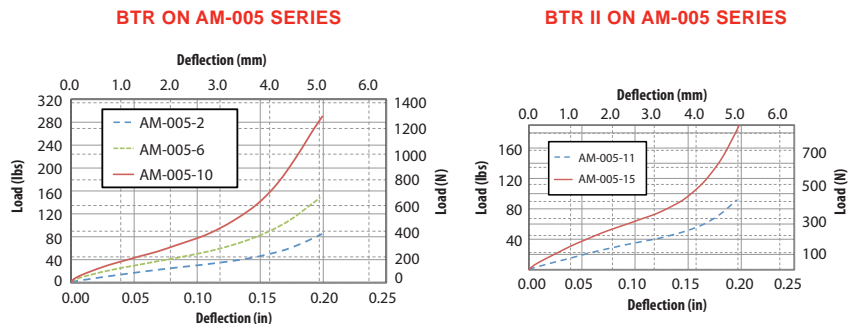

FIGURE 3 – TYPICAL LOAD VS. DEFLECTION VALUES



LOW PROFILE AVIONICS MOUNTS

AM-006 SERIES



- **Maximum static load per mount:**
10 lb (4.5 kg)
- **Maximum dynamic input at resonance:**
0.036 in (0.91 mm) D.A.
- **Weight:**
0.82 oz (23.3 g)

- **Materials:**
Metal parts and finish – aluminum alloy, chromate treated per MIL-DTL-5541, Class 1A
Inner member – 2024-T315 aluminum
Outer member – 2024-T315 aluminum
Elastomer – LORD BTR® or BTR® II Silicone

TABLE 1 – PERFORMANCE CHARACTERISTICS

Part Number	Axial Natural Frequency* - f_n (Hz)	Dynamic Axial Spring Rate		Dynamic Radial Spring Rate	
		lb/in	N/mm	lb/in	N/mm
BTR®					
AM-006-7	24	581	102	528	93
AM-006-8	26	681	119	619	108
AM-006-9	28	798	140	725	127
AM-006-10	30	932	163	847	148
AM-006-11	32	1065	187	968	170
AM-006-12	35	1221	214	1110	194
AM-006-13	37	1405	246	1277	224
AM-006-14	40	1611	282	1465	256
AM-006-15	43	1844	323	1676	294
BTR® II					
AM-006-1	23	550	96	500	88
AM-006-2	27	719	126	654	114
AM-006-3	30	938	164	853	149
AM-006-4	34	1169	205	1063	186
AM-006-5	39	1563	274	1421	249

* At 0.036 in (0.91 mm) D.A. input and maximum static load.

To correct for loads below rated loads, use:

$$f_n = f_{nn} \sqrt{P_R / P_A}$$

where:

f_n = natural frequency at actual load

f_{nn} = nominal natural frequency

P_A = actual load

P_R = rated load

FIGURE 3 – TYPICAL LOAD VS. DEFLECTION VALUES

BTR ON AM-006 SERIES

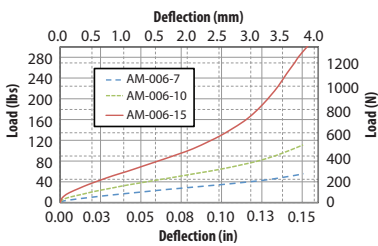

BTR II ON AM-006 SERIES

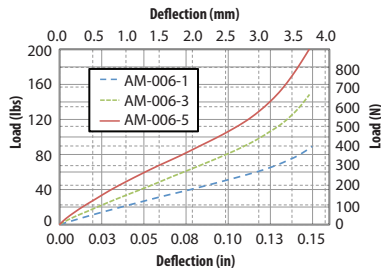
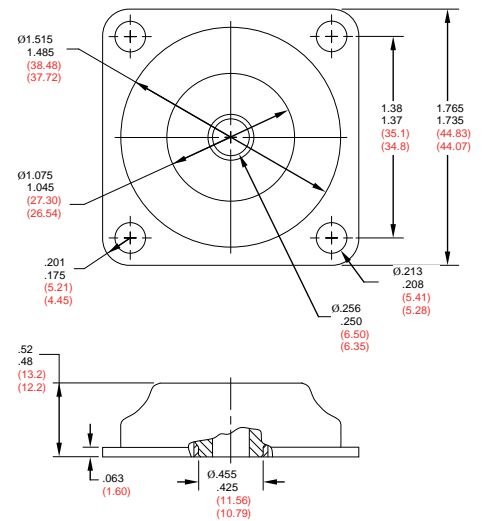
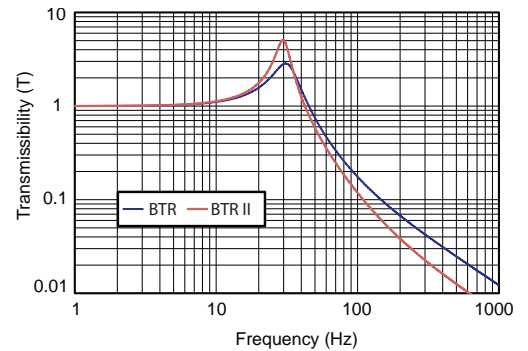

FIGURE 1 – PART DIMENSIONS



Metric values in parenthesis.

FIGURE 2 – TRANSMISSIBILITY VS. FREQUENCY



LOW PROFILE AVIONICS MOUNTS

AM-007 SERIES



- **Maximum static load per mount:**
15 lb (6.8 kg)
- **Maximum dynamic input at resonance:**
0.036 in (0.91 mm) D.A.
- **Weight:**
1.60 oz (45.4 g)

• **Materials:**

Metal parts and finish – aluminum alloy, chromate treated per MIL-DTL-5541, Class 1A
 Inner member – 2024-T315 aluminum
 Outer member – 2024-T315 aluminum
 Elastomer – LORD BTR® or BTR® II or MEA Silicone

FIGURE 1 – PART DIMENSIONS

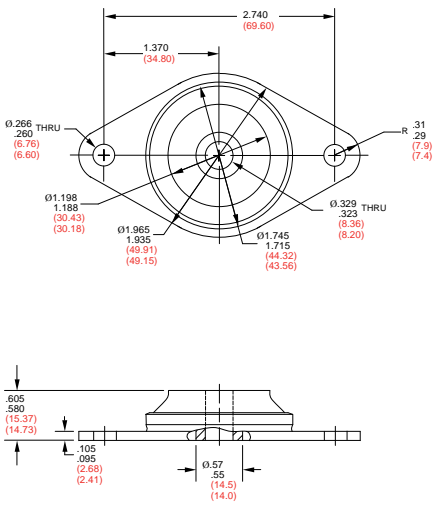

Metric values in parenthesis.

FIGURE 2 – TRANSMISSIBILITY VS. FREQUENCY

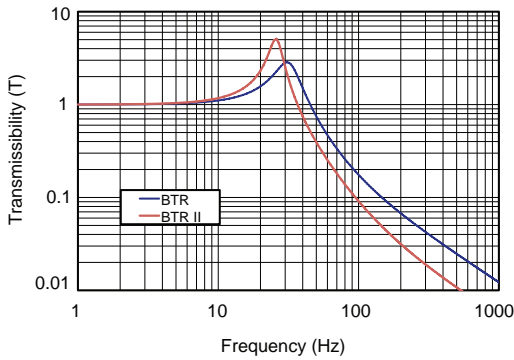

TABLE 1 – PERFORMANCE CHARACTERISTICS

Part Number	Axial Natural Frequency* - f_n (Hz)	Dynamic Axial Spring Rate		Dynamic Radial Spring Rate	
		lb/in	N/mm	lb/in	N/mm
BTR®					
AM-007-6	23	830	145	830	145
AM-007-7	26	1000	175	1000	175
AM-007-8	28	1170	205	1170	205
AM-007-9	30	1360	238	1360	238
AM-007-10	32	1610	282	1610	282
AM-007-11	35	1870	327	1870	327
AM-007-12	37	2130	373	2130	373
AM-007-13	40	2430	426	2430	426
AM-007-14	43	2800	490	2800	490
MEA					
AM-007-1	21	700	123	700	123
BTR® II					
AM-007-2	24	890	156	890	156
AM-007-3	26	1060	186	1060	186
AM-007-4	29	1260	221	1260	221
AM-007-5	31	1500	263	1500	263

* At 0.036 in (0.91 mm) D.A. input and maximum static load.

To correct for loads below rated loads, use:

$$f_n = f_{nn} \sqrt{P_R/P_A}$$

where:

f_n = natural frequency at actual load
 f_{nn} = nominal natural frequency
 P_A = actual load
 P_R = rated load

FIGURE 3 – TYPICAL LOAD VS. DEFLECTION VALUES

BTR ON AM-007 SERIES

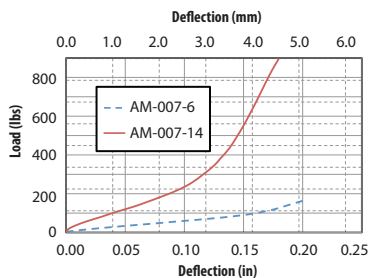

BTR II ON AM-007 SERIES

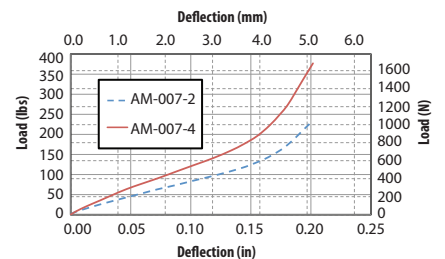

LOW PROFILE AVIONICS MOUNTS

AM-008 SERIES



- **Maximum static load per mount:**
20 lb (9.1 kg)
- **Maximum dynamic input at resonance:**
0.036 in (0.91 mm) D.A.
- **Weight:**
2.08 oz (59.0 g)

- **Materials:**
Metal parts and finish – aluminum alloy, chromate treated per MIL-DTL-5541, Class 1A
Inner member – 2024-T315 aluminum
Outer member – 2024-T315 aluminum
Elastomer – LORD BTR® or BTR® II or MEA Silicone

TABLE 1 – PERFORMANCE CHARACTERISTICS

Part Number	Axial Natural Frequency* - f_n (Hz)	Dynamic Axial Spring Rate		Dynamic Radial Spring Rate	
		lb/in	N/mm	lb/in	N/mm
BTR®					
AM-008-6	23	1100	193	1100	193
AM-008-7	26	1330	233	1330	233
AM-008-8	28	1560	273	1560	273
AM-008-9	30	1810	317	1810	317
AM-008-10	32	2150	377	2150	377
AM-008-11	35	2490	436	2490	436
AM-008-12	37	2840	497	2840	497
AM-008-13	40	3240	567	3240	567
AM-008-14	43	3700	648	3700	648
MEA					
AM-008-1	21	940	165	940	165
BTR® II					
AM-008-2	24	1180	207	1180	207
AM-008-3	26	1410	247	1410	247
AM-008-4	28	1680	294	1680	294
AM-008-5	31	2020	354	2020	354

* At 0.036 in (0.91 mm) D.A. input and maximum static load.

To correct for loads below rated loads, use:

$$f_n = f_{nm} \sqrt{P_R/P_A}$$

where:

f_n = natural frequency at actual load

f_{nm} = nominal natural frequency

P_A = actual load

P_R = rated load

FIGURE 3 – TYPICAL LOAD VS. DEFLECTION VALUES

BTR ON AM-008 SERIES

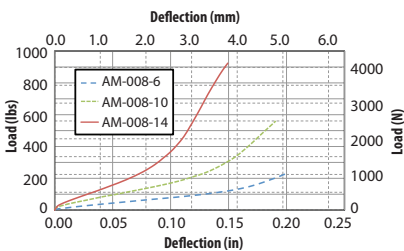

BTR II ON AM-008 SERIES

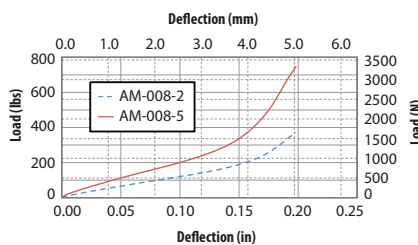
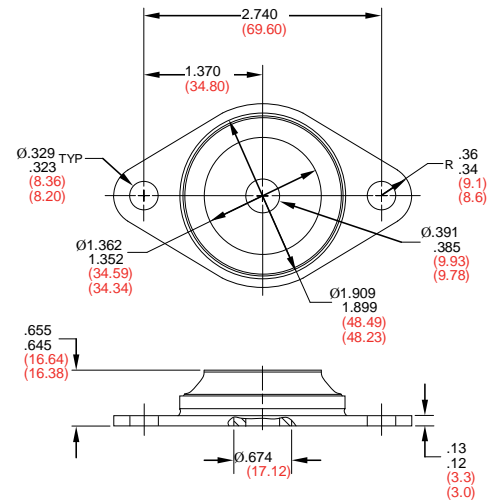
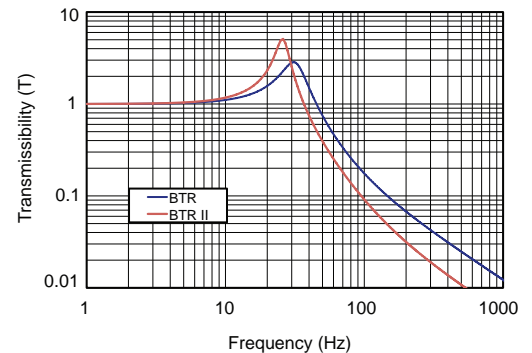

FIGURE 1 – PART DIMENSIONS



Metric values in parenthesis.

FIGURE 2 – TRANSMISSIBILITY VS. FREQUENCY



LOW PROFILE AVIONICS MOUNTS

AM-009 SERIES



• **Maximum static load per mount:**
25 lb (11.4 kg)

• **Maximum dynamic input at resonance:**
0.036 in (0.91 mm) D.A.

• **Weight:**
2.88 oz (81.6 g)

• **Materials:**

Metal parts and finish – aluminum alloy, chromate treated per MIL-DTL-5541, Class 1A

Inner member – 2024-T315 aluminum

Outer member – 2024-T315 aluminum

Elastomer – LORD BTR® or BTR® II or MEA Silicone

FIGURE 1 – PART DIMENSIONS

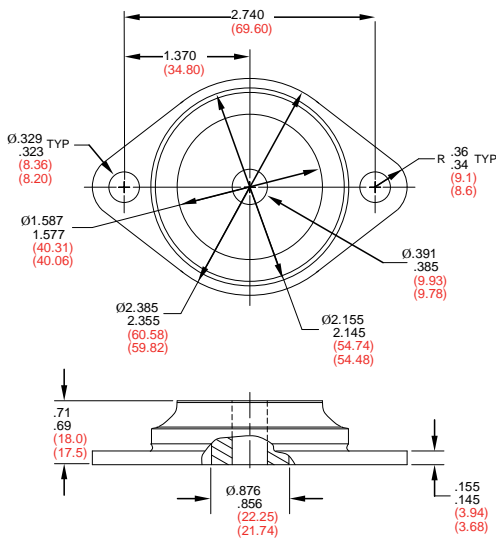

Metric values in parenthesis.

FIGURE 2 – TRANSMISSIBILITY VS. FREQUENCY

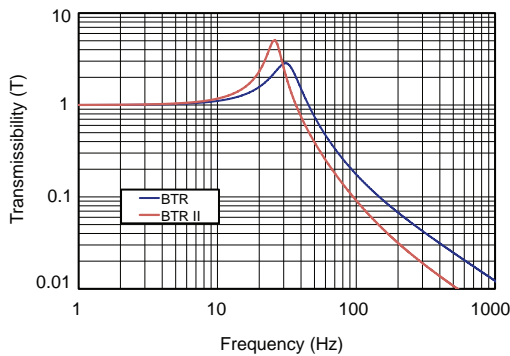

TABLE 1 – PERFORMANCE CHARACTERISTICS

Part Number	Axial Natural Frequency* - f_n (Hz)	Dynamic Axial Spring Rate		Dynamic Radial Spring Rate	
		lb/in	N/mm	lb/in	N/mm
BTR®					
AM-009-6	23	1350	236	1350	236
AM-009-7	26	1630	285	1630	285
AM-009-8	28	1910	334	1910	334
AM-009-9	30	2220	389	2220	389
AM-009-10	32	2640	462	2640	462
AM-009-11	35	3050	534	3050	534
AM-009-12	37	3480	609	3480	609
AM-009-13	39	3980	697	3980	697
AM-009-14	42	4550	797	4550	797
MEA					
AM-009-1	21	1150	201	1150	201
BTR® II					
AM-009-2	24	1450	254	1450	254
AM-009-3	26	1730	303	1730	303
AM-009-4	28	2060	361	2060	361
AM-009-5	31	2470	433	2470	433

* At 0.036 in (0.91 mm) D.A. input and maximum static load.

To correct for loads below rated loads, use:

$$f_n = f_{nm} \sqrt{P_R / P_A}$$

where:

f_n = natural frequency at actual load

f_{nm} = nominal natural frequency

P_A = actual load

P_R = rated load

FIGURE 3 – TYPICAL LOAD VS. DEFLECTION VALUES

BTR ON AM-009 SERIES

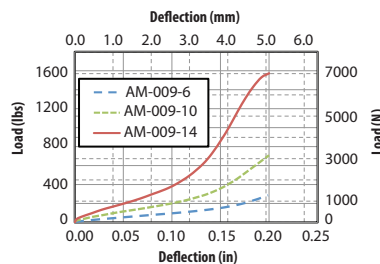

BTR II ON AM-009 SERIES

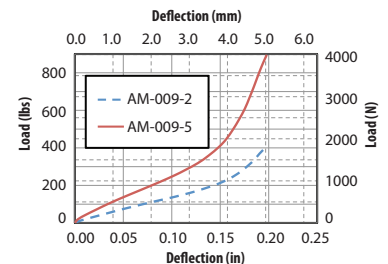

NOTES

NOTES

Lined area for notes.

MINIATURE MOUNTS

MAA SERIES | MGN/MGS SERIES | MCB SERIES

MINIATURE
MOUNTS

MINIATURE MOUNTS

MAA SERIES, MGN/MGS SERIES, MCB SERIES



STANDARDIZED SOLUTIONS FOR LIGHTWEIGHT ELECTRONIC EQUIPMENT

The Miniature Mount Series offer standardized solutions drawn from broad experience in the design of space conserving isolators for a variety of lightweight applications. They are suitable for use with circuit boards, sensors, displays, instruments, control and other electronic modules. Their compactness permits designs utilizing internal suspension arrangements, eliminating the need for sway space outside the case and providing an overall savings in weight.

A variety of configurations is offered so that the designer can select the geometry most appropriate to the applications. Miniature Mounts use specially compounded elastomers to assure control during resonant response.

All configurations are available with BTR® (Broad Temperature Range) elastomer, which provides excellent resonant control and is suitable for use over the temperature range of -65°F to +300°F (-54°C to +149°C). For applications where vibration isolation and returnability are paramount, selected styles are available using BTR® II elastomer which is suitable for use over the temperature range of -40°F to +300°F (-40°C to +149°C). For less demanding temperature requirements, the MGN Series uses natural rubber which is useful from -40°F to +180°F (-40°C to +82°C).

MINIATURE MOUNTS

MAA001 SERIES



- **Maximum rated load per mount:**
0.5 lb (0.23 kg)
- **Maximum dynamic input at resonance and rated load:**
0.011 in (0.279 mm) D.A.

- **Materials:**
Inner member – 304 stainless steel, passivated
Outer member – 2024-T351 aluminum, chromate treated per MIL-DTL-5541, Class 1A
Elastomer – LORD BTR® or BTR® II Silicone

FIGURE 1 – PART DIMENSIONS

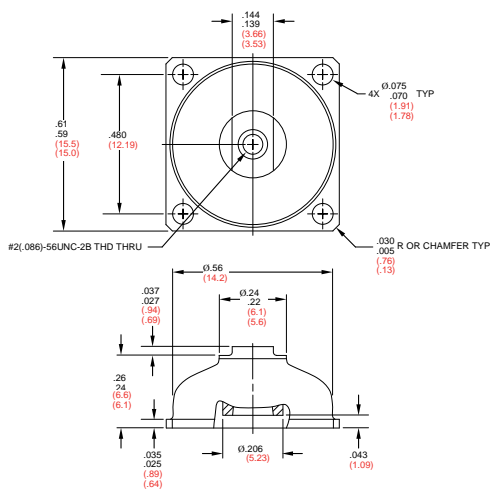

Metric values in parenthesis.

TABLE 1 – PERFORMANCE CHARACTERISTICS

Part Number	Dynamic Axial Spring Rate		Natural Frequency* – f _n (Hz)
	lb/in	N/mm	
BTR®			
MAA001-1	55	9.6	32
MAA001-2	65	11	36
MAA001-3	85	15	41
MAA001-4	95	17	43
MAA001-5	125	22	50
MAA001-6	152	27	55
MAA001-7	205	36	63
BTR® II			
MAA001-8	37	6.5	27
MAA001-9	43	7.5	30
MAA001-10	55	9.6	33
MAA001-11	72	13	38
MAA001-12	98	17	44

* Natural frequency at rated load and rated input.

To correct for loads below rated loads, use:

$$f_n = f_{nn} \sqrt{P_R/P_A}$$

where:

f_n = natural frequency at actual load

f_{nn} = nominal natural frequency

P_A = actual load

P_R = rated load

FIGURE 2 – TRANSMISSIBILITY VS. FREQUENCY

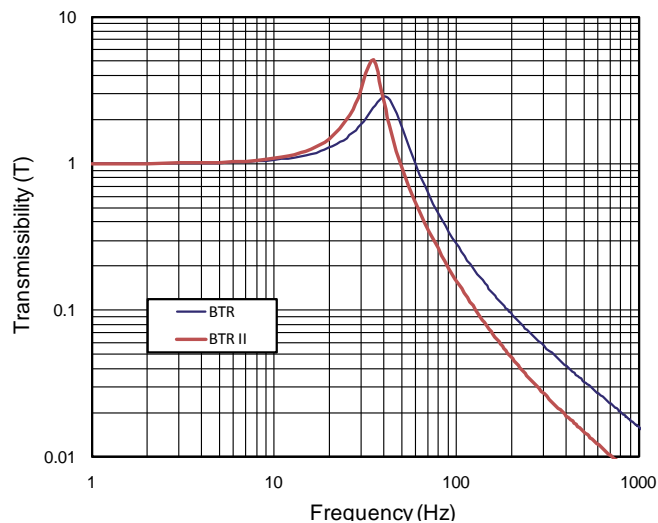

MINIATURE MOUNTS

MAA002 SERIES



- **Maximum rated load per mount:**
1 lb (0.45 kg)
- **Maximum dynamic input at resonance and rated load:**
0.011 in (0.279 mm) D.A.

- **Materials:**
Inner member – 304 stainless steel, passivated
Outer member – 2024-T351 aluminum, chromate treated per MIL-DTL-5541, Class 1A
Elastomer – LORD BTR® or BTR® II Silicone

TABLE 1 – PERFORMANCE CHARACTERISTICS

Part Number	Dynamic Axial Spring Rate		Natural Frequency* – f _n (Hz)
	lb/in	N/mm	
BTR®			
MAA002-1	99	17	31
MAA002-2	105	18	32
MAA002-3	115	20	34
MAA002-4	128	22	35
MAA002-5	140	25	37
MAA002-6	160	28	39
MAA002-7	180	32	42
BTR® II			
MAA002-8	76	13	27
MAA002-9	82	14	28
MAA002-10	90	16	30
MAA002-11	102	18	32
MAA002-12	120	21	34

* Natural frequency at rated load and rated input.

To correct for loads below rated loads, use:

$$f_n = f_{nn} \sqrt{P_R / P_A}$$

where:

f_n = natural frequency at actual load

f_{nn} = nominal natural frequency

P_A = actual load

P_R = rated load

FIGURE 1 – PART DIMENSIONS

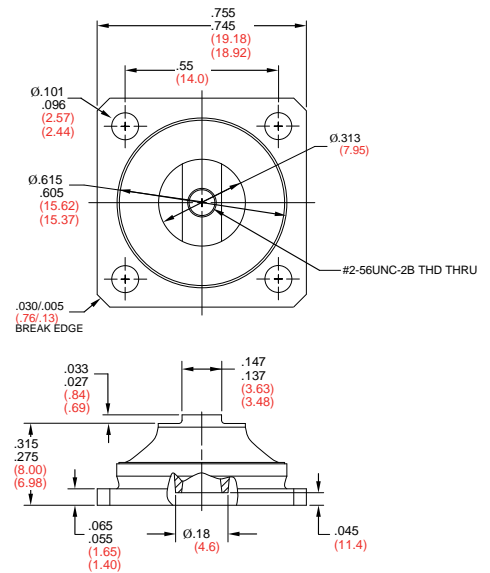

Metric values in parenthesis.

FIGURE 2 – TRANSMISSIBILITY VS. FREQUENCY

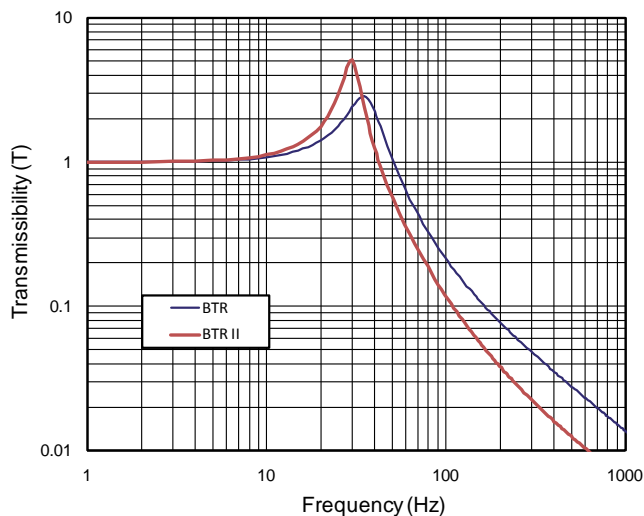

MINIATURE MOUNTS

MAA003 SERIES



- **Maximum rated load per mount:**
1.5 lb (0.68 kg)
- **Maximum dynamic input at resonance and rated load:**
0.011 in (0.279 mm) D.A.

- **Materials:**
Metal parts and finish – aluminum alloy, chromate treated per MIL-DTL-5541, Class 1A
Inner member – 2024-T315 or 2024-T4 aluminum
Outer member – 2024-T315 or 2024-T4 aluminum
Elastomer – LORD BTR® or BTR® II or MEB Silicone

FIGURE 1 – PART DIMENSIONS

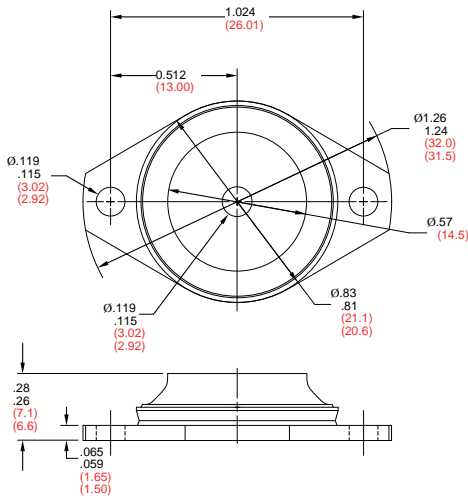

Metric values in parenthesis.

TABLE 1 – PERFORMANCE CHARACTERISTICS

Part Number	Dynamic Axial Spring Rate		Natural Frequency* – f_n (Hz)
	lb/in	N/mm	
BTR®			
MAA003-1	490	86	57
MAA003-2	625	109	64
MAA003-3	875	153	76
MAA003-4	1250	219	90
MAA003-5	1875	328	110
MEB			
MAA003-6	2685	470	132
MAA003-7	4185	732	165
BTR® II			
MAA003-8	315	55	45
MAA003-9	415	73	52
MAA003-10	560	98	60
MAA003-11	875	153	76

* Natural frequency at rated load and rated input.

To correct for loads below rated loads, use:

$$f_n = f_{nn} \sqrt{P_R/P_A}$$

where:

f_n = natural frequency at actual load

f_{nn} = nominal natural frequency

P_A = actual load

P_R = rated load

FIGURE 2 – TRANSMISSIBILITY VS. FREQUENCY

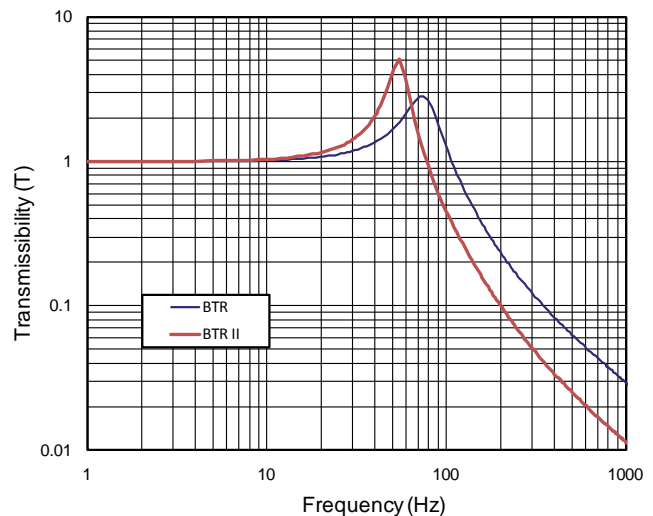

MINIATURE MOUNTS

MAA004 SERIES



- **Maximum rated load per mount:**
2 lb (0.91 kg)
- **Maximum dynamic input at resonance and rated load:**
0.011 in (0.279 mm) D.A.

- **Materials:**
Metal parts and finish – aluminum alloy, chromate treated per MIL-DTL-5541, Class 1A
Inner member and Outer member – 2024-T315 aluminum
Threaded insert – stainless steel
Elastomer – LORD BTR® or BTR® II Silicone

TABLE 1 – PERFORMANCE CHARACTERISTICS

Part Number	Dynamic Axial Spring Rate		Natural Frequency* – f_n (Hz)
	lb/in	N/mm	
BTR®			
MAA004-1	800	140	63
MAA004-2	1000	175	70
MAA004-3	1250	219	78
MAA004-4	1625	284	90
MAA004-5	2190	383	104
MAA004-6	2875	503	120
BTR® II			
MAA004-8	550	96	52
MAA004-9	665	116	57
MAA004-10	875	153	65
MAA004-11	1130	198	75
MAA004-12	1200	219	77

* Natural frequency at rated load and rated input.

To correct for loads below rated loads, use:

$$f_n = f_{nn} \sqrt{P_R/P_A}$$

where:

f_n = natural frequency at actual load

f_{nn} = nominal natural frequency

P_A = actual load

P_R = rated load

FIGURE 1 – PART DIMENSIONS

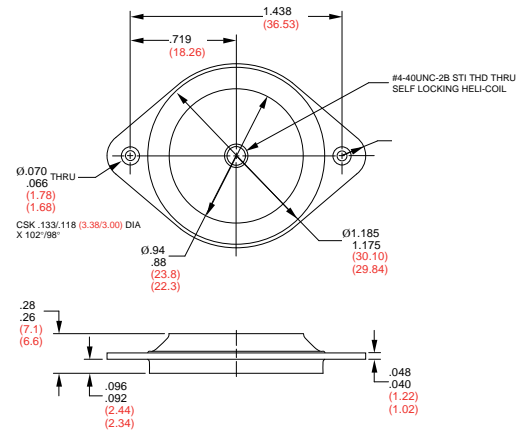

Metric values in parenthesis.

FIGURE 2 – TRANSMISSIBILITY VS. FREQUENCY

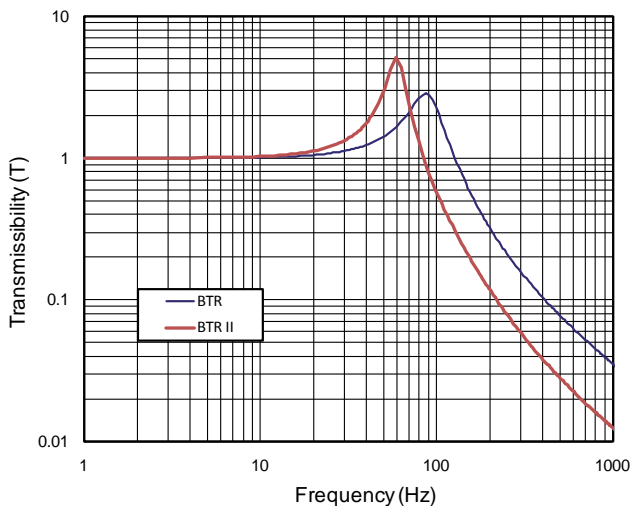

MINIATURE MOUNTS

MGN/MGS001 SERIES



• **Maximum rated load per mount:**
1 to 4 lb (0.5 to 1.8 kg)

• **Maximum dynamic input at resonance:**
0.01 in (0.254 mm) D.A.

• **Materials:**

Optional Ferrule – brass

Elastomer – LORD BTR® or MEM Silicone or Natural rubber

FIGURE 1 – PART DIMENSIONS WITHOUT FERRULE

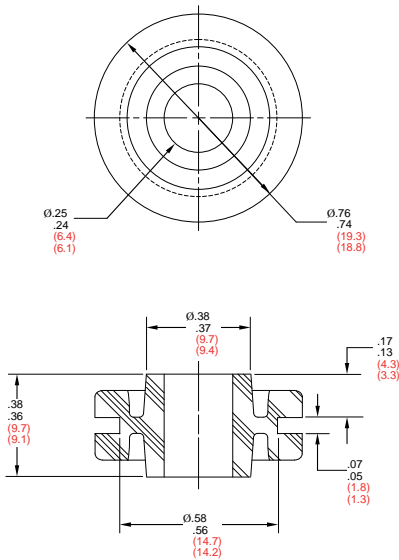

Metric values in parenthesis.

FIGURE 2 – PART DIMENSIONS WITH PLAIN FERRULE

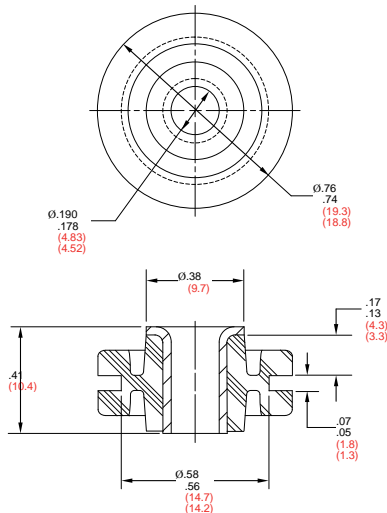

Metric values in parenthesis.

TABLE 1 – PERFORMANCE CHARACTERISTICS

Part Number	Rated Load		Rated Input		Dynamic Axial Spring Rate		Natural Freq [†] – f _n (Hz)
	lb	kg	in D.A.	mm D.A.	lb/in	N/mm	
NR							
MGN001-* ⁻ 1	1.5	0.7	0.010	0.254	43	7.5	18
MGN001-* ⁻ 2	2.0	0.9	0.010	0.254	66	12	18
MGN001-* ⁻ 3	3.0	1.4	0.010	0.254	102	18	18
MGN001-* ⁻ 4	4.0	1.8	0.010	0.254	137	24	18
MEM							
MGS001-* ⁻ 1	1.0	0.5	0.010	0.254	42	7.4	20
BTR®							
MGS001-* ⁻ 2	1.5	0.7	0.010	0.254	62	11	20
MGS001-* ⁻ 3	2.5	1.1	0.010	0.254	95	17	20
MGS001-* ⁻ 4	3.5	1.6	0.010	0.254	144	25	20

* When ordering, use the following in place of the (*):
W = Without ferrule^{††}
P = Includes plain ferrule (LORD p/n Y-10879-B)

[†] Natural frequency at rated load and rated input.

^{††} If no ferrule, recommended space dimensions for positive tightening are:
Length = 0.365 in (9.27 mm)
O.D. = 0.255 in (6.48 mm)

Recommended support member plate dimensions:
Thickness = 0.062 in
Diameter = 0.555 in
Break all sharp edges.

To correct for loads below rated loads, use:

$$f_n = f_{nn} \sqrt{P_R/P_A}$$

where:

f_n = natural frequency at actual load
f_{nn} = nominal natural frequency
P_A = actual load
P_R = rated load

FIGURE 3 – TRANSMISSIBILITY VS. FREQUENCY

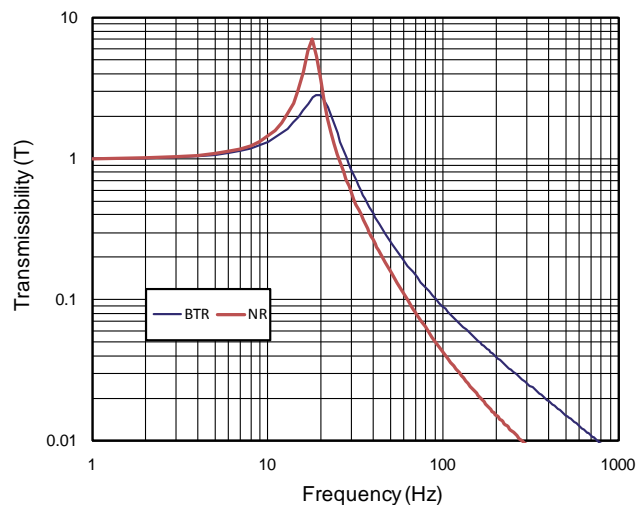

MINIATURE MOUNTS

MGN/MGS002 SERIES



- **Maximum rated load per mount:**
1 to 4 lb (0.5 to 1.8 kg)
- **Maximum dynamic input at resonance:**
0.01 in (0.254 mm) D.A.

- **Materials:**
Optional Ferrule – SAE 1010 steel, zinc plated
Elastomer – LORD BTR® or MEM Silicone or Natural rubber

TABLE 1 – PERFORMANCE CHARACTERISTICS

Part Number	Rated Load		Rated Input		Dynamic Axial Spring Rate		Natural Freq† – f_n (Hz)
	lb	kg	in D.A.	mm D.A.	lb/in	N/mm	
NR							
MGN002- [*] -1	1.5	0.7	0.010	0.254	43	7.5	18
MGN002- [*] -2	2.0	0.9	0.010	0.254	66	12	18
MGN002- [*] -3	3.0	1.4	0.010	0.254	102	18	18
MGN002- [*] -4	4.0	1.8	0.010	0.254	137	24	18
MEM							
MGS002- [*] -1	1.0	0.5	0.010	0.254	42	7.4	20
BTR®							
MGS002- [*] -2	1.5	0.7	0.010	0.254	62	11	20
MGS002- [*] -3	2.5	1.1	0.010	0.254	95	17	20
MGS002- [*] -4	3.5	1.6	0.010	0.254	144	25	20

* When ordering, use the following in place of the (*):
W = Without ferrule††
T = Includes threaded ferrule (LORD p/n Y-31124-4-1)

† Natural frequency at rated load and rated input.

†† If no ferrule, recommended space dimensions for positive tightening are:
Length = 0.365 in (9.27 mm)
O.D. = 0.255 in (6.48 mm)

Recommended support member plate dimensions:
Thickness = 0.062 in
Diameter = 0.555 in
Break all sharp edges.

To correct for loads below rated loads, use:

$$f_n = f_{nn} \sqrt{P_R/P_A}$$

where:

f_n = natural frequency at actual load

f_{nn} = nominal natural frequency

P_A = actual load

P_R = rated load

FIGURE 1 – PART DIMENSIONS WITHOUT FERRULE

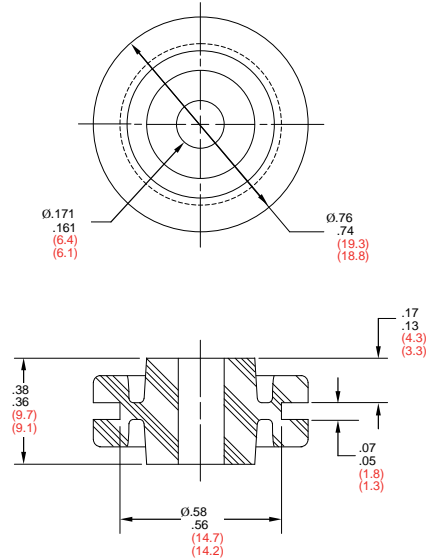

Metric values in parenthesis.

FIGURE 2 – PART DIMENSIONS WITH THREADED FERRULE

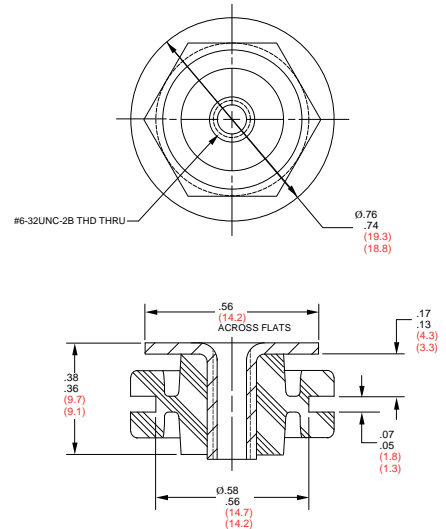

Metric values in parenthesis.

FIGURE 3 – TRANSMISSIBILITY VS. FREQUENCY

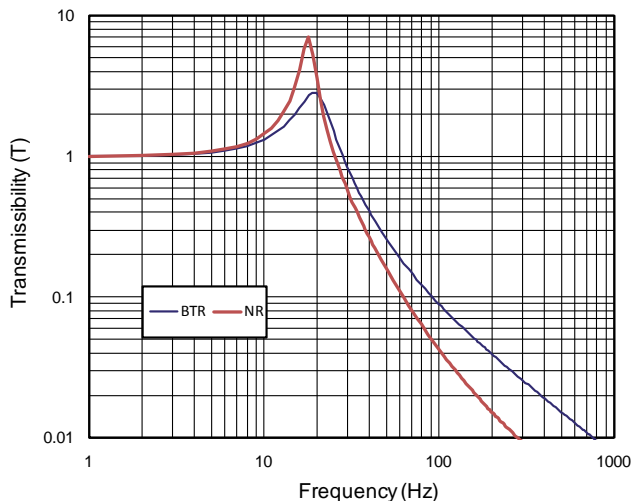

MINIATURE MOUNTS

MGN/MGS003 SERIES



- **Maximum rated load per mount:**
1 to 2 lb (0.5 to 0.9 kg)
- **Maximum dynamic input at resonance:**
0.015 in (0.381 mm) D.A.

- **Materials:**
Ferrule – SAE 1010 steel, zinc plated
Elastomer – LORD BTR® Silicone or Natural rubber

FIGURE 1 – PART DIMENSIONS WITHOUT FERRULE

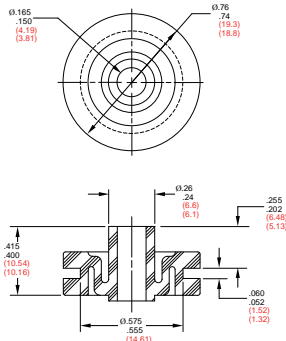

Metric values in parenthesis.

FIGURE 2 – PART DIMENSIONS WITH PLAIN FERRULE

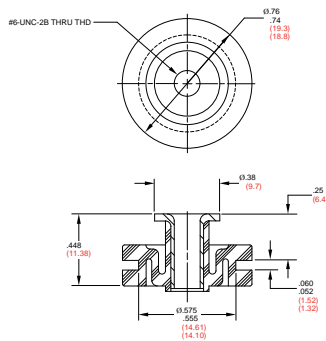

Metric values in parenthesis.

FIGURE 3 – PART DIMENSIONS WITH THREADED FERRULE

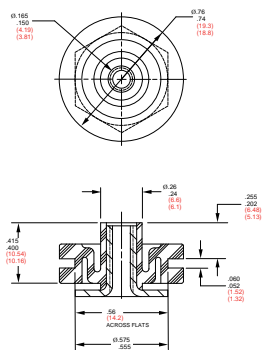

Metric values in parenthesis.

TABLE 1 – PERFORMANCE CHARACTERISTICS

Part Number	Rated Load		Rated Input		Dynamic Axial Spring Rate		Natural Freq [†] – f _n (Hz)
	lb	kg	in D.A.	mm D.A.	lb/in	N/mm	
NR							
MGN003*-1	1.5	0.7	0.015	0.381	29	5.1	14
MGN003*-2	2.0	0.9	0.015	0.381	42	7.4	14
BTR®							
MGS003*-1	1.0	0.5	0.015	0.381	26	4.6	16
MGS003*-2	1.5	0.7	0.015	0.381	35	6.1	16

* When ordering, use the following in place of the (*):

W = Without ferrule††
P = Includes plain ferrule (LORD p/n Y-31124-7-1)
T = Includes threaded ferrule (LORD p/n Y-31124-4-1)

† Natural frequency at rated load and rated input.

†† If no ferrule, recommended space dimensions for positive tightening are:

Length = 0.365 in (9.27 mm)
O.D. = 0.175 in (4.45 mm)

Recommended support member plate dimensions:

Thickness = 0.062 in
Diameter = 0.555 in
Break all sharp edges.

To correct for loads below rated loads, use:

$$f_n = f_{nn} \sqrt{P_R/P_A}$$

where:

f_n = natural frequency at actual load

f_{nn} = nominal natural frequency

P_A = actual load

P_R = rated load

FIGURE 4 – TRANSMISSIBILITY VS. FREQUENCY

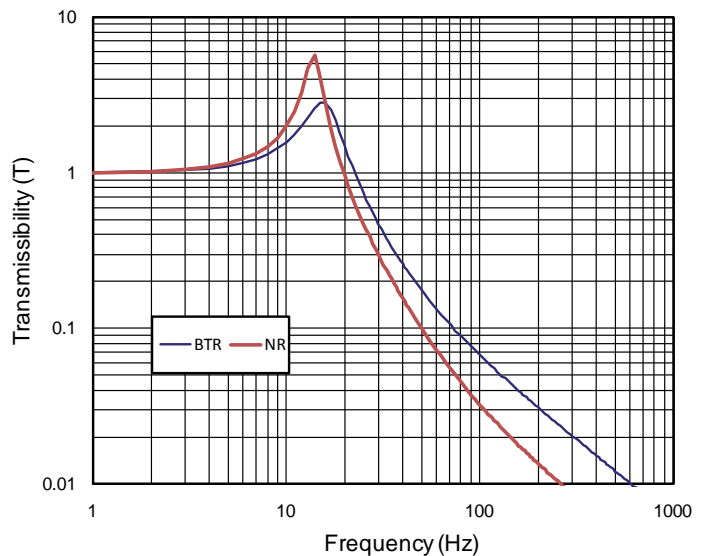

MINIATURE MOUNTS

MCB002 SERIES



- **Maximum rated load per mount:**
0.75 lb (0.34 kg)
- **Maximum dynamic input at resonance and rated load:**
2 g

- **Materials:**
Inner member – 303 stainless steel, passivated
Elastomer – LORD BTR® Silicone

TABLE 1 – PERFORMANCE CHARACTERISTICS

Part Number	Dynamic Axial Spring Rate		Natural Frequency* – f_n (Hz)
	lb/in	N/mm	
MCB002-1	1000	175	115
MCB002-2	1840	322	155
MCB002-3	2340	410	175

* Natural frequency at rated load and rated input.

To correct for loads below rated loads, use:

$$f_n = f_{nn} \sqrt{P_R / P_A}$$

where:

f_n = natural frequency at actual load

f_{nn} = nominal natural frequency

P_A = actual load

P_R = rated load

FIGURE 1 – PART DIMENSIONS

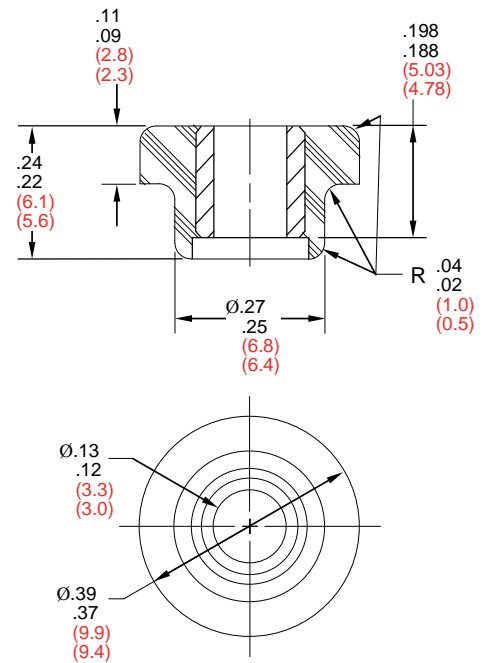

Metric values in parenthesis.

NOTE: Install one per mounting location.

FIGURE 3 – TRANSMISSIBILITY VS. FREQUENCY

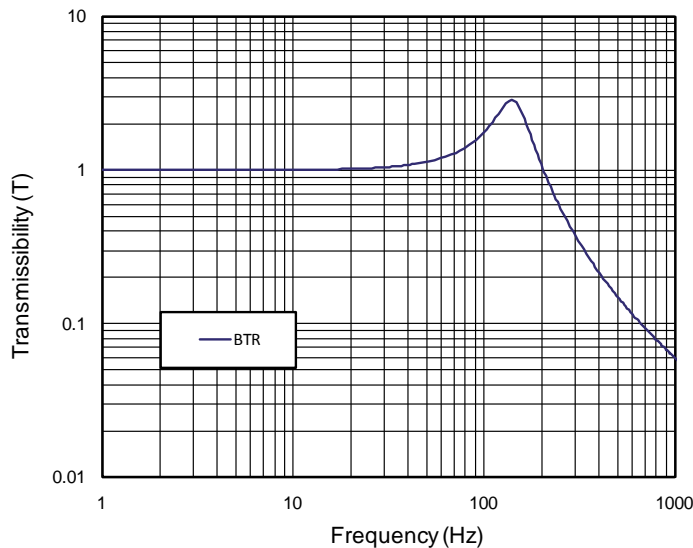
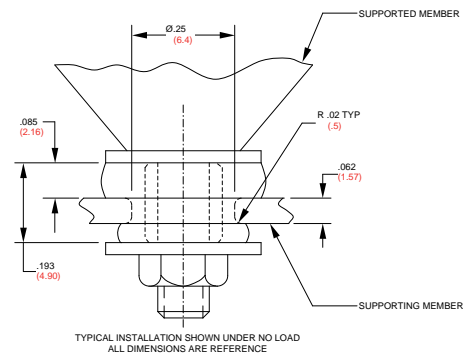

FIGURE 2 – INSTALLATION DRAWING



TYPICAL INSTALLATION SHOWN UNDER NO LOAD
ALL DIMENSIONS ARE REFERENCE

Metric values in parenthesis.

NOTE: Install one per mounting location.

MINIATURE MOUNTS

MCB003 SERIES



- **Maximum rated load per mount:**
1.5 lb (0.68 kg)
- **Maximum dynamic input at resonance and rated load:**
2 g

- **Materials:**
Inner member – 303 stainless steel, passivated
Elastomer – LORD BTR® Silicone

FIGURE 1 – PART DIMENSIONS

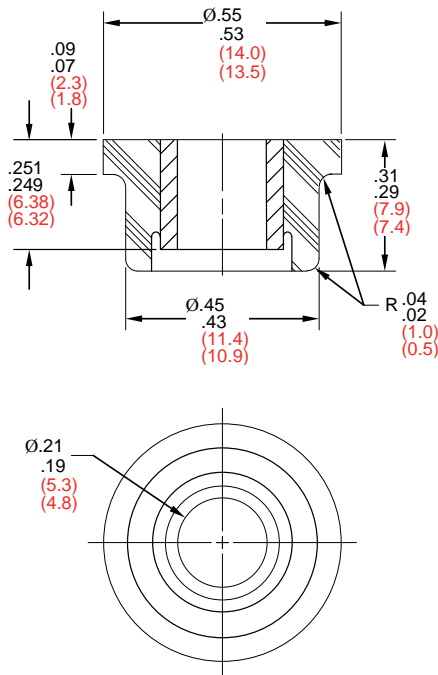

Metric values in parenthesis.

NOTE: Install one per mounting location.

FIGURE 2 – INSTALLATION DRAWING

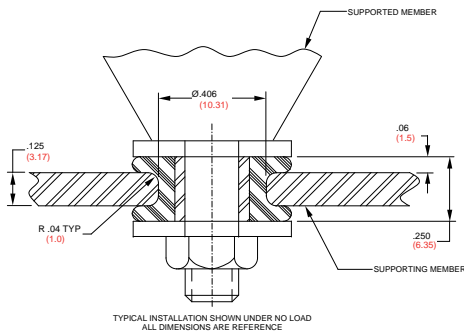

Metric values in parenthesis.

NOTE: Install one per mounting location.

TABLE 1 – PERFORMANCE CHARACTERISTICS

Part Number	Dynamic Axial Spring Rate		Natural Frequency* – f_n (Hz)
	lb/in	N/mm	
MCB003-1	5130	900	183
MCB003-2	6750	1190	210
MCB003-3	8100	1420	230

* Natural frequency at rated load and rated input.

To correct for loads below rated loads, use:

$$f_n = f_{nn} \sqrt{P_R/P_A}$$

where:

f_n = natural frequency at actual load

f_{nn} = nominal natural frequency

P_A = actual load

P_R = rated load

FIGURE 3 – TRANSMISSIBILITY VS. FREQUENCY

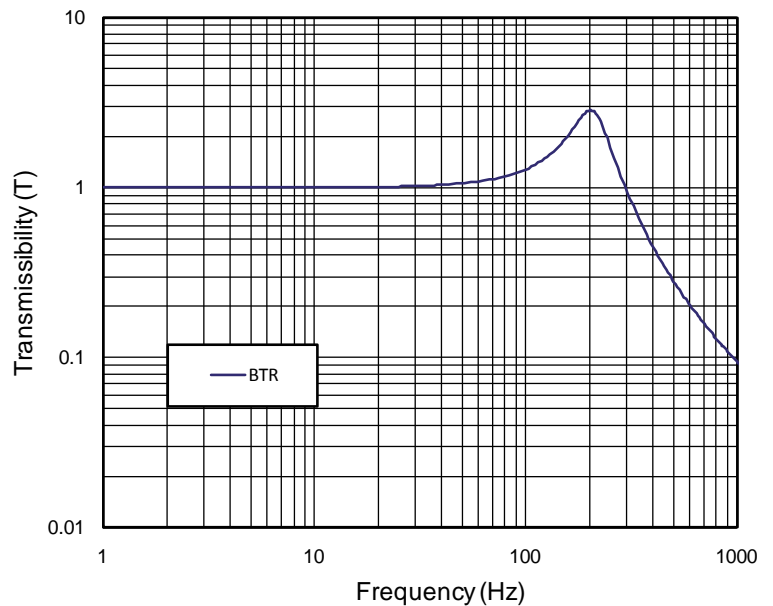

MINIATURE MOUNTS

MCB004 SERIES



- **Maximum rated load per pair:**
1 lb (0.45 kg)
- **Maximum dynamic input at resonance and rated load:**
2 g

- **Materials:**
Inner member – 304 stainless steel, passivated
Elastomer – LORD BTR® Silicone

TABLE 1 – PERFORMANCE CHARACTERISTICS (PER PAIR)

Part Number	Dynamic Axial Spring Rate		Natural Frequency* – f_n (Hz)
	lb/in	N/mm	
MCB004-1	575	101	75
MCB004-2	1375	241	115
MCB004-3	2000	350	140

* Natural frequency at rated load and rated input.

To correct for loads below rated loads, use:

$$f_n = f_{nn} \sqrt{P_R/P_A}$$

where:

f_n = natural frequency at actual load

f_{nn} = nominal natural frequency

P_A = actual load

P_R = rated load

FIGURE 1 – PART DIMENSIONS

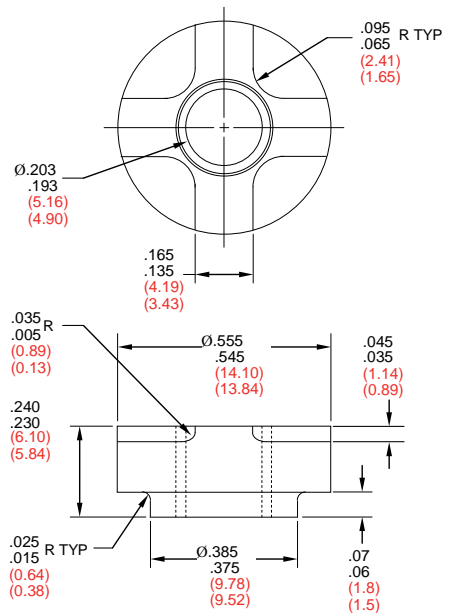

Metric values in parenthesis.

NOTE: Install one per mounting location.

FIGURE 3 – TRANSMISSIBILITY VS. FREQUENCY

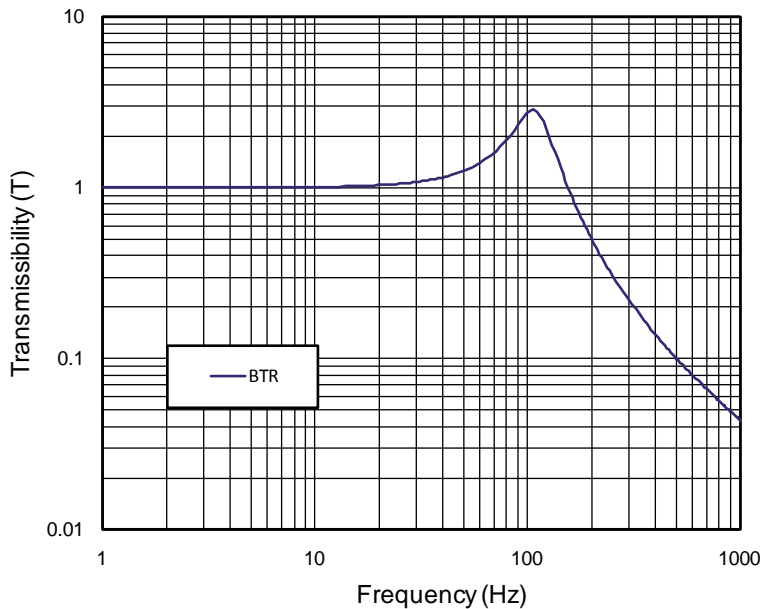
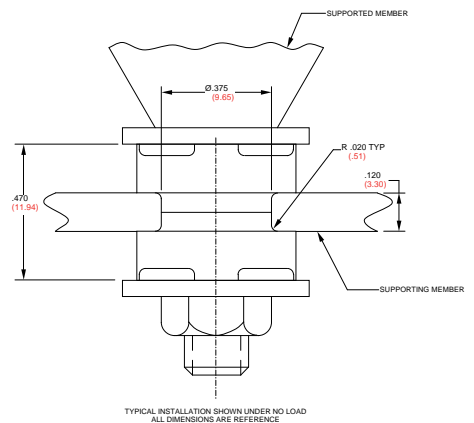

FIGURE 2 – INSTALLATION DRAWING



Metric values in parenthesis.

NOTE: Install one per mounting location.

MINIATURE MOUNTS

MCB005 SERIES



- **Maximum rated load per pair:**
10 lb (4.55 kg)
- **Maximum dynamic input at resonance and rated load:**
2 g

- **Materials:**
Inner member – 2024-T4 aluminum, chromate treated per MIL-DTL-5541, Class 1A
Elastomer – LORD BTR® Silicone

FIGURE 1 – PART DIMENSIONS

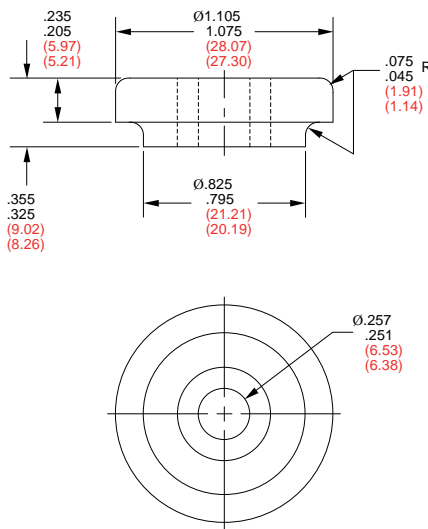

Metric values in parenthesis.

NOTE: Install in pairs at each mounting location.

FIGURE 2 – INSTALLATION DRAWING

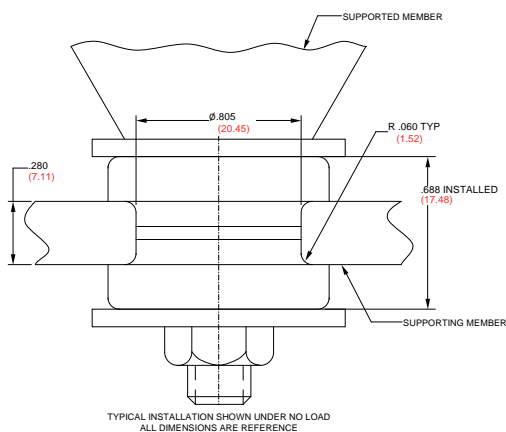

Metric values in parenthesis.

NOTE: Install in pairs at each mounting location.

TABLE 1 – PERFORMANCE CHARACTERISTICS (PER PAIR)

Part Number	Dynamic Axial Spring Rate per Pair		Natural Frequency* – f_n (Hz)
	lb/in	N/mm	
MCB005-1	5000	875	70
MCB005-2	6000	1050	75
MCB005-3	7400	1295	85
MCB005-4	8300	1453	90
MCB005-5	9400	1645	95
MCB005-6	10500	1838	100
MCB005-7	11600	2030	105
MCB005-8	13000	2275	110
MCB005-9	14700	2573	120

* Natural frequency at rated load and rated input.

To correct for loads below rated loads, use:

$$f_n = f_{nn} \sqrt{P_R/P_A}$$

where:

f_n = natural frequency at actual load

f_{nn} = nominal natural frequency

P_A = actual load

P_R = rated load

FIGURE 3 – TRANSMISSIBILITY VS. FREQUENCY

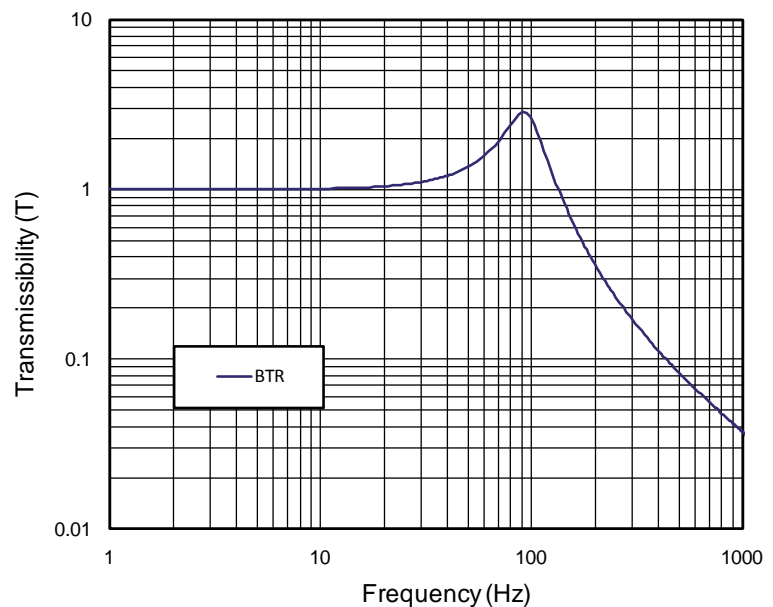

MINIATURE MOUNTS

MCB006 SERIES



- **Maximum rated load per pair:**
5 lb (2.27 kg)
- **Maximum dynamic input at resonance and rated load:**
2 g

• **Materials:**

Inner member – 2024-T4 aluminum, chromate treated per MIL-DTL-5541, Class 1A
Elastomer – LORD BTR® Silicone

TABLE 1 – PERFORMANCE CHARACTERISTICS (PER PAIR)

Part Number	Dynamic Axial Spring Rate per Pair		Natural Frequency* – f_n (Hz)
	lb/in	N/mm	
MCB006-1	2500	438	70
MCB006-2	2900	508	75
MCB006-3	3300	578	80
MCB006-4	3675	643	85
MCB006-5	4200	735	90
MCB006-6	4775	836	95
MCB006-7	5600	980	105
MCB006-8	6200	1085	110
MCB006-9	6900	1208	115

* Natural frequency at rated load and rated input.

To correct for loads below rated loads, use:

$$f_n = f_{nn} \sqrt{P_R / P_A}$$

where:

- f_n = natural frequency at actual load
- f_{nn} = nominal natural frequency
- P_A = actual load
- P_R = rated load

FIGURE 1 – PART DIMENSIONS

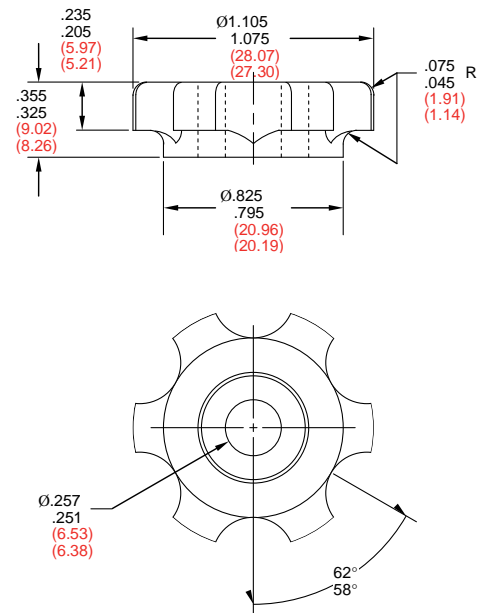

Metric values in parenthesis.

NOTE: Install in pairs at each mounting location.

FIGURE 3 – TRANSMISSIBILITY VS. FREQUENCY

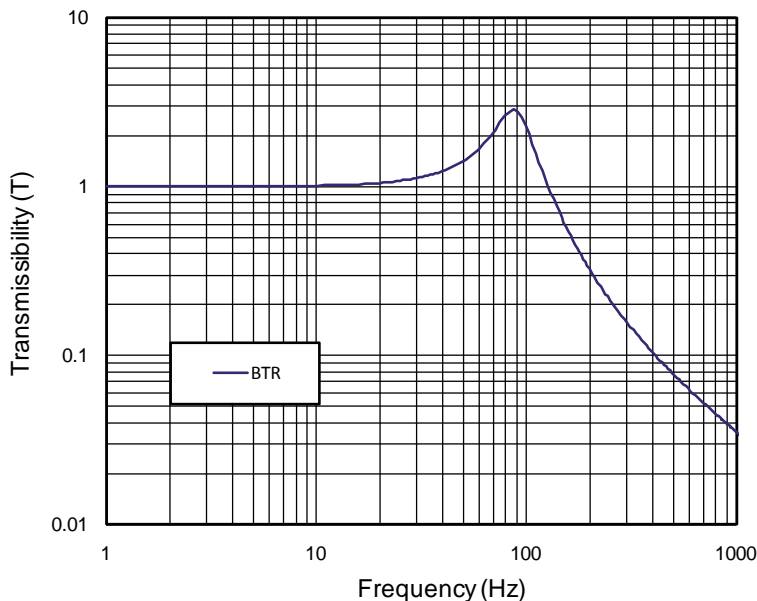
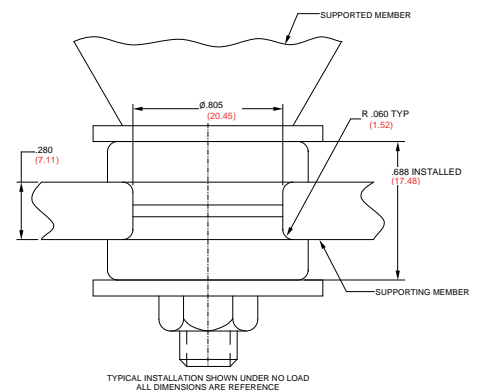

FIGURE 2 – INSTALLATION DRAWING



TYPICAL INSTALLATION SHOWN UNDER NO LOAD
ALL DIMENSIONS ARE REFERENCE

Metric values in parenthesis.

NOTE: Install in pairs at each mounting location.

MICRO-MOUNTS™

MX SERIES

MICRO-MOUNTS™



FOR SENSITIVE ELECTRONIC COMPONENTS

The Micro-Mount Series are unique, high-performance isolators small enough and soft enough to isolate individual sensitive electronic components and circuit boards.

The Micro-Mount Series is designed to isolate individual components and circuit boards — eliminating the need to isolate entire systems. These small, flexible mounts have been used successfully on GPS oscillators in satellites and on military aircraft.

Made of BTR® (Broad Temperature Range) silicone bonded to stainless-steel, these mounts are ideal for applications where minimal change over temperature is required. And, the combination of this unique high-end silicone with stainless-steel components assures easy installation in a wide range of applications.

MICRO-MOUNTS™

MX002 SERIES



- **Rated static load per mount:**
0.1 lb (46 g)
- **Maximum static load per mount:**
0.2 lb (92 g)
- **Maximum dynamic input at resonance and rated load:**
0.02 in (0.507 mm) D.A.

- **Materials:**
Hex nuts – 303 stainless steel, passivated
Elastomer – LORD MEA Silicone

FIGURE 1 – PART DIMENSIONS

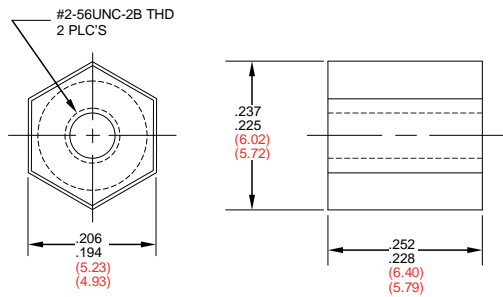

Metric values in parenthesis.

TABLE 1 – PERFORMANCE CHARACTERISTICS

Part Number	Dynamic Shear Spring Rate		Dynamic Axial Spring Rate		Natural Frequency* – f_n (Hz)	
	lb/in	N/mm	lb/in	N/mm	Shear	Axial
MX002-1	5.4	0.9	24.5	4.2	23	49
MX002-2	7.4	1.3	32	5.5	27	32
MX002-3	11.8	2	47.2	8.1	34	68

* Natural frequency at rated load and rated input (0.1 lb and 0.02 inch D.A. sine vibration).

FIGURE 2 – TRANSMISSIBILITY VS. FREQUENCY

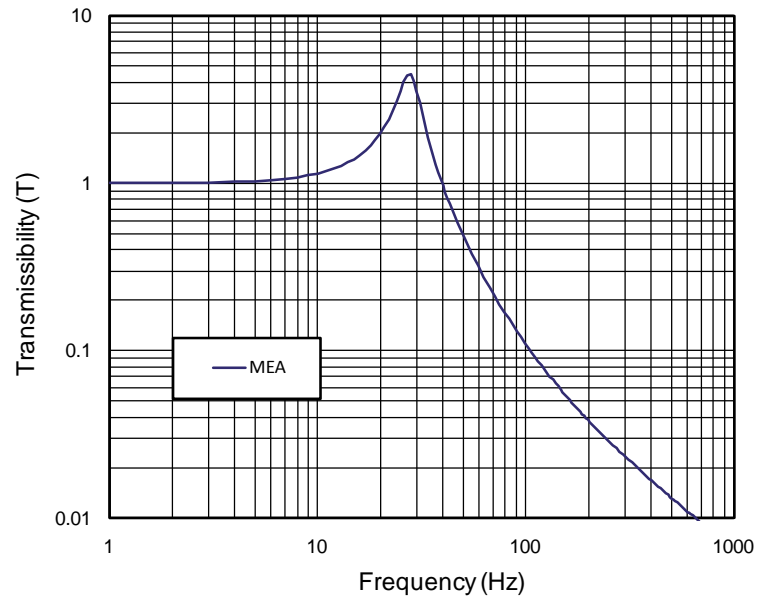

MICRO-MOUNTS™

MX003 SERIES



- **Rated static load per mount:**
0.1 lb (46 g)
- **Maximum static load per mount:**
0.2 lb (92 g)
- **Maximum dynamic input at resonance and rated load:**
0.02 in (0.507 mm) D.A.

- **Materials:**
Hex nuts – 303 stainless steel, passivated
Elastomer – LORD MEA Silicone

TABLE 1 – PERFORMANCE CHARACTERISTICS

Part Number	Dynamic Shear Spring Rate		Dynamic Axial Spring Rate		Natural Frequency* – f_n (Hz)	
	lb/in	N/mm	lb/in	N/mm	Shear	Axial
MX003-1	2.3	0.4	14	2.4	15	37
MX003-2	4.1	0.7	19.8	3.4	20	44
MX003-3	6.9	1.2	32	5.5	26	56

* Natural frequency at rated load and rated input (0.1 lb and 0.02 inch D.A. sine vibration).

FIGURE 1 – PART DIMENSIONS

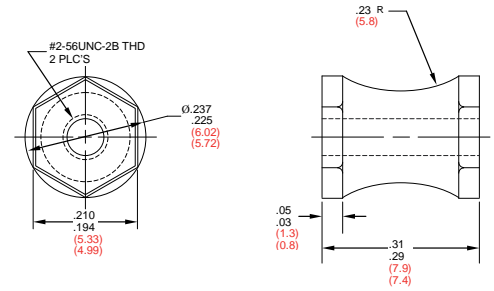

Metric values in parenthesis.

FIGURE 2 – TRANSMISSIBILITY VS. FREQUENCY

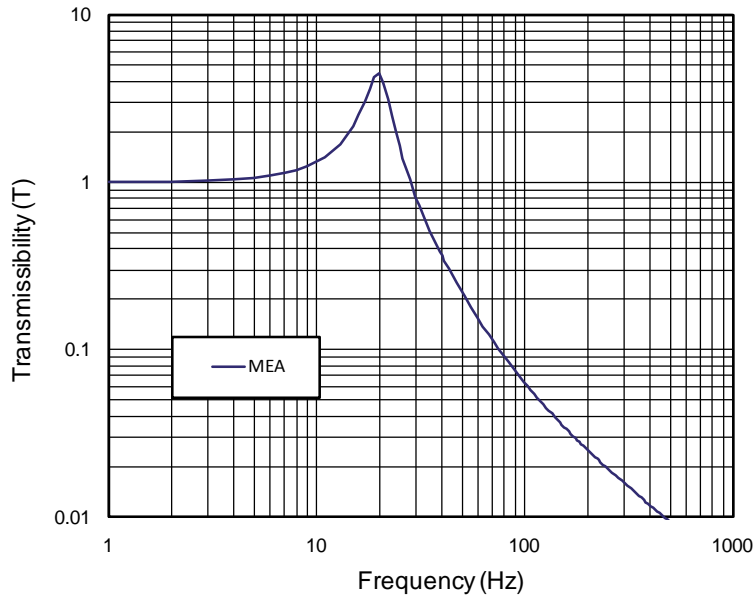

NOTES

PLATE FORM MOUNTS

100 SERIES | 150 SERIES

PLATE FORM
MOUNTS

PLATE FORM MOUNTS

100 SERIES, 150 SERIES

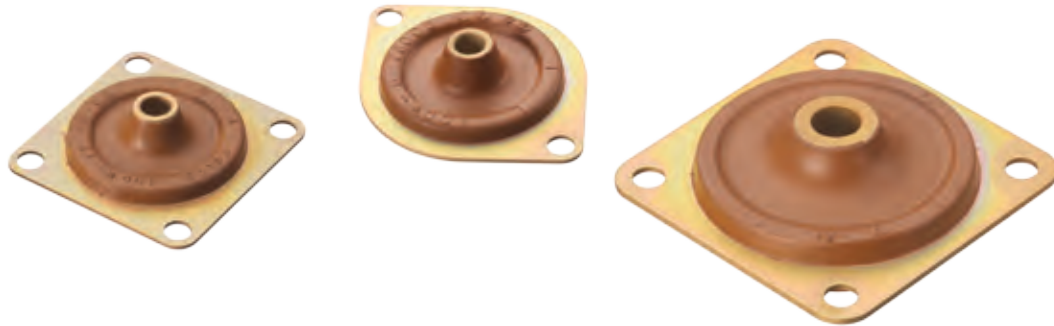

FOR ISOLATION OF STEADY VIBRATION AND CONTROL OF OCCASIONAL SHOCK

Standard stock Plate Form Mounts are widely used to efficiently isolate steady-state vibration and control occasional shock.

These versatile mounts are available in load ratings of 0.25 to 12 pounds per mount. When loaded to their rated capacity, a system natural frequency of approximately 18 Hz results, providing effective isolation in applications where disturbing frequencies are 40 Hz and above. Radial stiffness is approximately two to three times the axial stiffness.

Standard Plate Form Mounts are easy to install. They are available in square or diamond configurations to suit a variety of design requirements. The contour of the flexing element provides uniform stress distribution. This, plus high-strength bonding and specially compounded elastomers, provide maximum service life.

NOTE: Snubbing washers are recommended for use with Plate Form Mounts. They form an interlocking system of metal parts, providing a positive safety, which limits and cushions excessive movement from overload and shock.

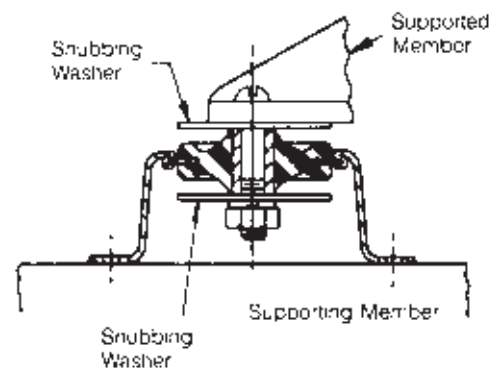
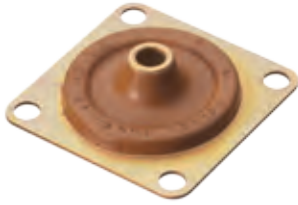

FIGURE 1 – TYPICAL INSTALLATION

PLATE FORM MOUNTS

100APL SERIES



- **Load capacity:**
0.25 to 6 lb (0.10 to 2.7 kg)

- **Materials:**
Metal parts and finish – aluminum alloy, chromate treated per MIL-DTL-5541, Class 1A
Inner member – 2024-T4 aluminum
Outer member – 2024-T3 or 2024-T4 aluminum
Elastomer – LORD BTR® or BTR® II Silicone

FIGURE 1 – PART DIMENSIONS

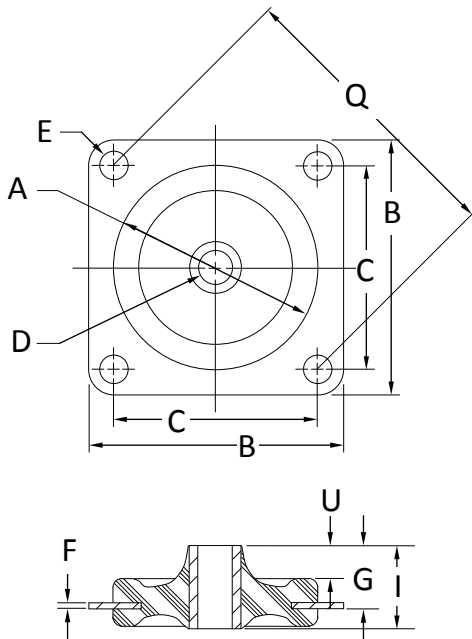

FIGURE 2 – TRANSMISSIBILITY VS. FREQUENCY

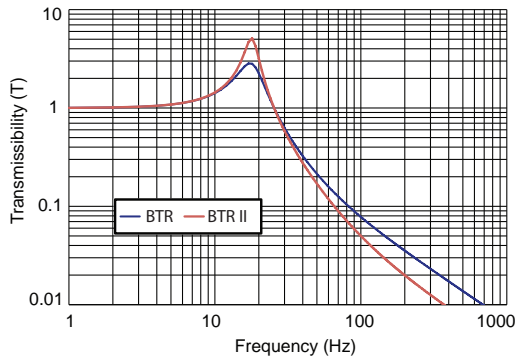

TABLE 1 – PERFORMANCE CHARACTERISTICS

Part Number	Static Load		Nominal Axial Natural Freq [†] (Hz)	Dynamic Axial Spring Rate [†]		Dimensions Under No Load			
	lb	kg		lb/in	N/mm	in		mm	
						G [*]	I	G [*]	I
100APL [*] -A	¼	0.10	18	8	1.4	0.30	0.41	7.6	10.4
100APL [*] -B	½	0.20	18	17	2.9	0.30	0.41	7.6	10.4
100APL [*] -1	1	0.45	18	33	5.7	0.30	0.41	7.6	10.4
100APL [*] -1B	1½	0.70	18	50	8.7	0.30	0.41	7.6	10.4
100APL [*] -2	2	0.90	18	67	11.6	0.30	0.41	7.6	10.4
100APL [*] -3	3	1.40	18	100	17.4	0.30	0.41	7.6	10.4
100APL [*] -4	4	1.80	18	133	23.1	0.33	0.50	8.4	12.7
100APL [*] -5	5	2.30	18	167	29.1	0.39	0.62	9.9	15.7
100APL [*] -6	6	2.70	18	200	34.8	0.45	0.75	11.4	19.0

* When ordering, use the following in place of the (*):
Q = BTR II elastomer
W = BTR elastomer
† At 0.036 in (0.91 mm) D.A. input and rated load.
* Reference dimensions.

TABLE 2 – DIMENSIONS UNDER NO LOAD

	A [*]	B	C	D +0.008/-0.005 (+.20/-12)	E +0.003/-0.002 (+.07/-05)	F	Q	U [*]
in	1.00	1.25	1.00	0.166	0.141	0.032	1.414	0.15
mm	25.4	31.7	25.40	4.22	3.58	0.81	35.92	3.8

* Reference dimensions.

TABLE 3 – SNUBBING WASHER DIMENSIONS

Part Number	Outside Diameter	Inside Diameter	Thickness
J-2049-1D			
in	0.88	0.17	0.03
mm	22.3	4.3	0.8

PLATE FORM MOUNTS

100APDL SERIES



- **Load capacity:**
0.25 to 6 lb (0.10 to 2.7 kg)

- **Materials:**
Metal parts and finish – aluminum alloy, chromate treated per MIL-DTL-5541, Class 1A
Inner member – 2024-T4 aluminum
Outer member – 2024-T3 or 2024-T4 aluminum
Elastomer – LORD BTR® or BTR® II Silicone

TABLE 1 – PERFORMANCE CHARACTERISTICS

Part Number	Static Load		Nominal Axial Natural Freq [†] (Hz)	Dynamic Axial Spring Rate [†]		Dimensions Under No Load			
	lb	kg		lb/in	N/mm	in		mm	
						G [*]	I	G [*]	I
100APDL [*] -A	¼	0.10	18	8	1.4	0.30	0.41	7.6	10.4
100APDL [*] -B	½	0.20	18	17	2.9	0.30	0.41	7.6	10.4
100APDL [*] -1	1	0.45	18	33	5.7	0.30	0.41	7.6	10.4
100APDL [*] -1B	1½	0.70	18	50	8.7	0.30	0.41	7.6	10.4
100APDL [*] -2	2	0.90	18	67	11.6	0.30	0.41	7.6	10.4
100APDL [*] -3	3	1.40	18	100	17.4	0.30	0.41	7.6	10.4
100APDL [*] -4	4	1.80	18	133	23.1	0.33	0.50	8.4	12.7
100APDL [*] -5	5	2.30	18	167	29.1	0.39	0.62	9.9	15.7
100APDL [*] -6	6	2.70	18	200	34.8	0.45	0.75	11.4	19.0

* When ordering, use the following in place of the (*):
Q = BTR II elastomer
W = BTR elastomer
† At 0.036 in (0.91 mm) D.A. input and rated load.
* Reference dimensions.

TABLE 2 – DIMENSIONS UNDER NO LOAD

	A [*]	D +0.008/-0.005 (+20/-12)	E +0.003/-0.002 (+07/-05)	F	Q	R	S	U [*]
in	1.00	0.166	0.141	0.032	1.414	0.62	1.66	0.15
mm	25.4	4.22	3.58	0.81	35.92	15.7	42.2	3.8

* Reference dimensions.

TABLE 3 – SNUBBING WASHER DIMENSIONS

Part Number	Outside Diameter	Inside Diameter	Thickness
J-2049-1D			
in	0.88	0.17	0.03
mm	22.3	4.3	0.80

FIGURE 1 – PART DIMENSIONS

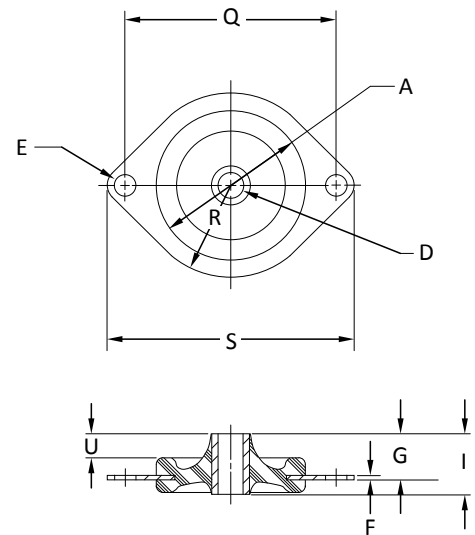

FIGURE 2 – TRANSMISSIBILITY VS. FREQUENCY

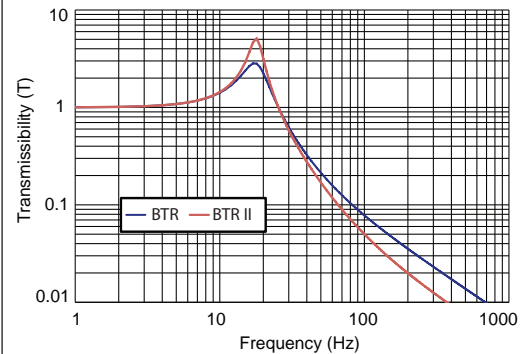
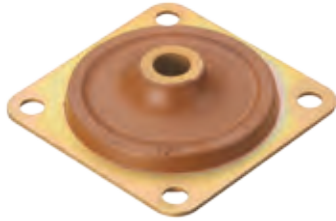

PLATE FORM MOUNTS

150APL SERIES



- **Load capacity:**
1 to 12 lb (0.45 to 5.4 kg)

- **Materials:**
Metal parts and finish – aluminum alloy, chromate treated per MIL-DTL-5541, Class 1A
Inner member – 2024-T4 aluminum
Outer member – 2024-T3 or 2024-T4 aluminum
Elastomer – LORD BTR® or BTR® II Silicone

FIGURE 1 – PART DIMENSIONS

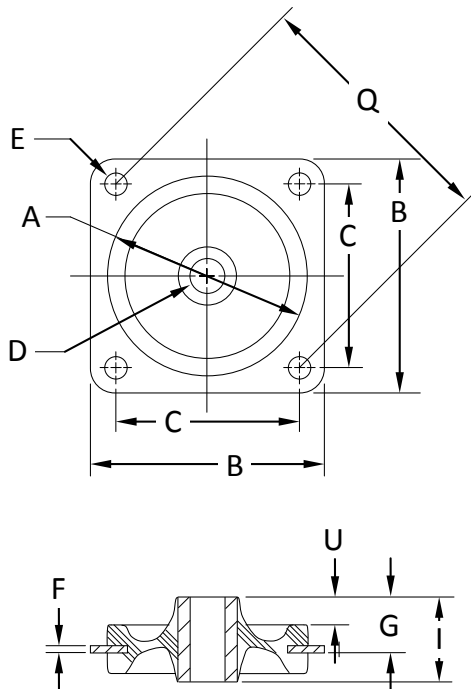

FIGURE 2 – TRANSMISSIBILITY VS. FREQUENCY

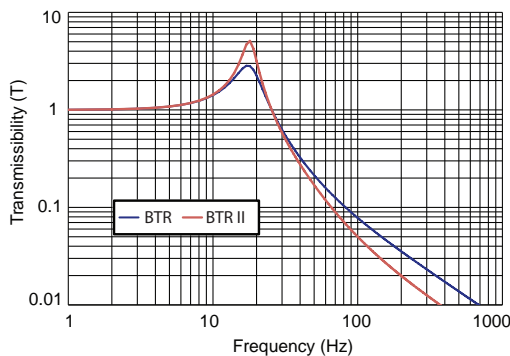

TABLE 1 – PERFORMANCE CHARACTERISTICS

Part Number	Static Load		Nominal Axial Natural Freq [†] (Hz)	Dynamic Axial Spring Rate [†]		Dimensions Under No Load			
	lb	kg		lb/in	N/mm	in		mm	
						G *	I	G *	I
150APL*-1	1	0.45	18	33	5.7	0.40	0.62	10.2	15.7
150APL*-2	2	0.90	18	67	12	0.40	0.62	10.2	15.7
150APL*-3	3	1.40	18	100	17	0.40	0.62	10.2	15.7
150APL*-4	4	1.80	18	133	23	0.40	0.62	10.2	15.7
150APL*-5	5	2.30	18	167	29	0.40	0.62	10.2	15.7
150APL*-6	6	2.70	18	200	35	0.40	0.62	10.2	15.7
150APL*-7	7	3.17	18	233	41	0.40	0.62	10.2	15.7
150APL*-8	8	3.60	18	267	47	0.40	0.62	10.2	15.7
150APL*-9	9	4.10	18	300	52	0.56	0.88	14.2	22.3
150APL*-12	12	5.40	18	400	70	0.68	1.12	17.3	28.4

* When ordering, use the following in place of the (*):

Q = BTR II elastomer

W = BTR elastomer

[†] At 0.036 in (0.91 mm) D.A. input and rated load.

* Reference dimensions.

TABLE 2 – DIMENSIONS UNDER NO LOAD

	A *	B	C	D +0.008/-0.005 (+20/-12)	E +0.003/-0.002 (+0.7/-0.5)	F	Q	U *
in	1.50	1.75	1.375	0.257	0.166	0.050	1.945	0.18
mm	38.1	44.4	34.92	6.53	4.22	1.27	49.40	4.6

* Reference dimensions.

TABLE 3 – SNUBBING WASHER DIMENSIONS

Part Number	Outside Diameter	Inside Diameter	Thickness
J-2049-1D			
in	1.38	0.26	0.05
mm	35.0	6.6	1.3

PLATE FORM MOUNTS

150APDL SERIES



- **Load capacity:**
1 to 12 lb (0.45 to 5.4 kg)

- **Materials:**
Metal parts and finish – aluminum alloy, chromate treated per MIL-DTL-5541, Class 1A
Inner member – 2024-T4 aluminum
Outer member – 2024-T3 or 2024-T4 aluminum
Elastomer – LORD BTR® or BTR® II Silicone

TABLE 1 – PERFORMANCE CHARACTERISTICS

Part Number	Static Load		Nominal Axial Natural Freq [†] (Hz)	Dynamic Axial Spring Rate [†]		Dimensions Under No Load			
						in		mm	
	lb	kg		lb/in	N/mm	G	I [*]	G	I [*]
150APDL*-1	1	0.45	18	33	5.7	0.40	0.62	10.2	15.7
150APDL*-2	2	0.90	18	67	12	0.40	0.62	10.2	15.7
150APDL*-3	3	1.40	18	100	17	0.40	0.62	10.2	15.7
150APDL*-4	4	1.80	18	133	23	0.40	0.62	10.2	15.7
150APDL*-5	5	2.30	18	167	29	0.40	0.62	10.2	15.7
150APDL*-6	6	2.70	18	200	35	0.40	0.62	10.2	15.7
150APDL*-7	7	3.17	18	233	41	0.40	0.62	10.2	15.7
150APDL*-8	8	3.60	18	267	47	0.40	0.62	10.2	15.7
150APDL*-9	9	4.10	18	300	52	0.56	0.88	14.2	22.3
150APDL*-12	12	5.40	18	400	70	0.68	1.12	17.3	28.4

* When ordering, use the following in place of the (*):
Q = BTR II elastomer
W = BTR elastomer
† At 0.036 in (0.91 mm) D.A. input and rated load.
*Reference dimensions.

TABLE 2 – DIMENSIONS UNDER NO LOAD

	A [*]	D +0.008/-0.005 (+0.20/-12)	E +0.003/-0.002 (+0.07/-0.05)	F	Q	R	S	U [*]
in	1.50	0.257	0.166	0.050	1.945	0.88	2.32	0.18
mm	38.1	6.53	4.22	1.27	49.40	22.4	58.9	4.6

* Reference dimensions.

TABLE 3 – SNUBBING WASHER DIMENSIONS

Part Number J-2049-1D	Outside Diameter	Inside Diameter	Thickness
in	1.38	0.26	0.05
mm	35.0	6.6	1.3

FIGURE 1 – PART DIMENSIONS

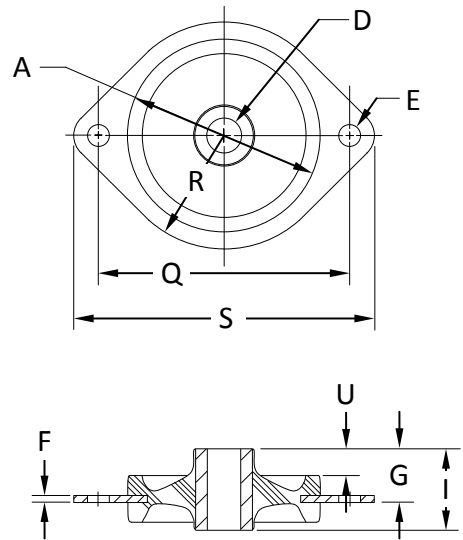
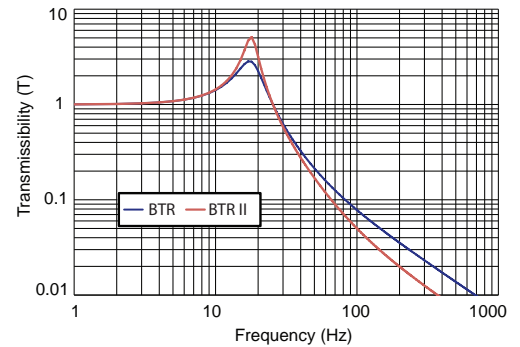

FIGURE 2 – TRANSMISSIBILITY VS. FREQUENCY



NOTES

A series of horizontal lines providing a space for notes.

MULTIPLANE MOUNTS

106 SERIES | 156 SERIES

MULTIPLANE
MOUNTS

MULTIPLANE MOUNTS

106 SERIES, 156 SERIES



ECONOMICAL PROTECTION FROM LOWER FREQUENCY VIBRATION

Standard stock Multiplane Mounts are recommended for the isolation of vibration. Lightweight and compact, they provide economical protection from lower frequency disturbances regardless of directions of the forces. They are not recommended where severe, frequently recurring shock is encountered.

These mounts are available in load ratings from 0.25 to 8 pounds per unit. When loaded to their capacity, a system natural frequency of approximately 10 Hz results, providing effective isolation in applications where disturbing frequencies are above 20 Hz. The radial stiffness is the same as that in the axial direction.

Multiplane Mounts are easy to install. They are available in square or diamond configurations to suit a variety of design requirements.

The contour of the flexing element provides uniform stress distribution.

Snubbing washers provide an interlocking system of metal parts which act to prevent damage from overload or excessive shock impact.

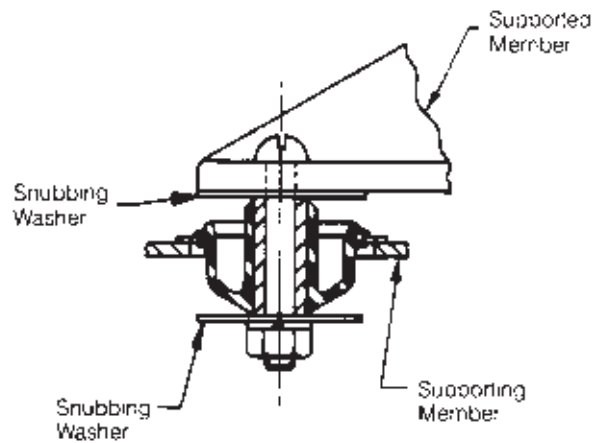

FIGURE 1 – TYPICAL INSTALLATION

MULTIPLANE MOUNTS

106APL SERIES



- **Load capacity:**
0.25 to 2 lb (0.10 to 0.90 kg)

- **Materials:**
Metal parts and finish – aluminum alloy, chromate treated per MIL-DTL-5541, Class 1A
Inner member – 2024-T4 aluminum
Outer member – 2024-T3 or 2024-T4 aluminum
Elastomer – LORD BTR® or BTR® II Silicone

FIGURE 1 – PART DIMENSIONS

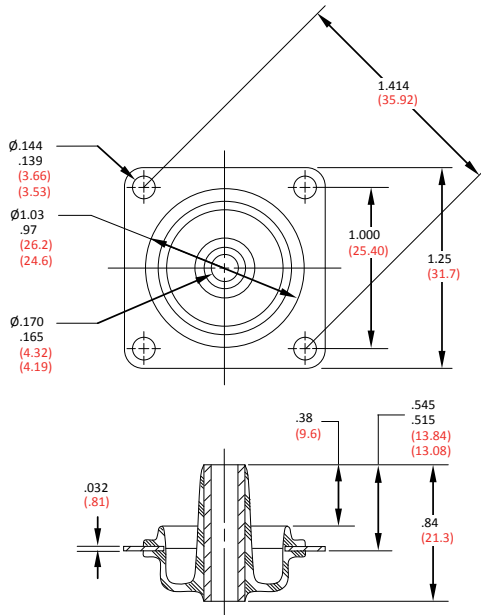

Metric values in parenthesis.

TABLE 1 – PERFORMANCE CHARACTERISTICS

Part Number	Static Load		Nominal Axial Natural Freq ¹ (Hz)	Dynamic Axial Spring Rate ¹	
	lb	kg		lb/in	N/mm
106APL*-A	¼	0.11	18	8	1.4
106APL*-B	½	0.23	18	17	3.0
106APL*-C	¾	0.34	16	20	3.4
106APL*-1	1	0.45	16	26	4.6
106APL*-1B	1½	0.68	14	30	5.3
106APL*-2	2	0.91	14	40	7.0

* When ordering, use the following in place of the (*):

Q = BTR II elastomer

W = BTR elastomer

¹ At 0.036 in (0.91 mm) D.A. input and rated load.

TABLE 2 – SNUBBING WASHER DIMENSIONS

Part Number J-2049-1D	Outside Diameter	Inside Diameter	Thickness
in	0.88	0.17	0.03
mm	22.3	4.3	0.8

FIGURE 2 – TRANSMISSIBILITY VS. FREQUENCY

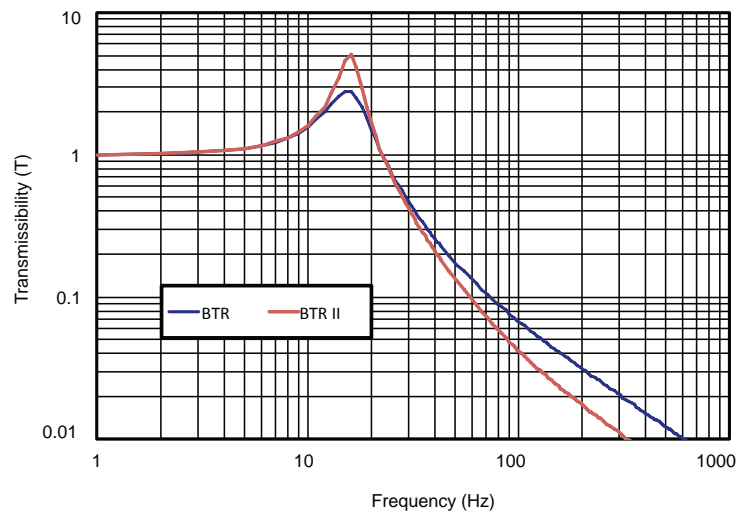

MULTIPLANE MOUNTS

106APDL SERIES



- **Load capacity:**
0.25 to 2 lb (0.10 to 0.90 kg)

- **Materials:**
Metal parts and finish – aluminum alloy, chromate treated per MIL-DTL-5541, Class 1A
Inner member – 2024-T4 aluminum
Outer member – 2024-T3 or 2024-T4 aluminum
Elastomer – LORD BTR® or BTR® II Silicone

TABLE 1 – PERFORMANCE CHARACTERISTICS

Part Number	Static Load		Nominal Axial Natural Freq ¹ (Hz)	Dynamic Axial Spring Rate [†]	
	lb	kg		lb/in	N/mm
106APDL*-A	¼	0.11	18	8	1.4
106APDL*-B	½	0.23	18	17	3.0
106APDL*-C	¾	0.34	16	20	3.4
106APDL*-1	1	0.45	16	26	4.6
106APDL*-1B	1½	0.68	14	30	5.3
106APDL*-2	2	0.91	14	40	7.0

* When ordering, use the following in place of the (*):
Q = BTR II elastomer
W = BTR elastomer
† At 0.036 in (0.91 mm) D.A. input and rated load.

TABLE 2 – SNUBBING WASHER DIMENSIONS

Part Number	Outside Diameter	Inside Diameter	Thickness
J-2049-1D			
in	0.88	0.17	0.03
mm	22.3	4.3	0.8

FIGURE 1 – PART DIMENSIONS

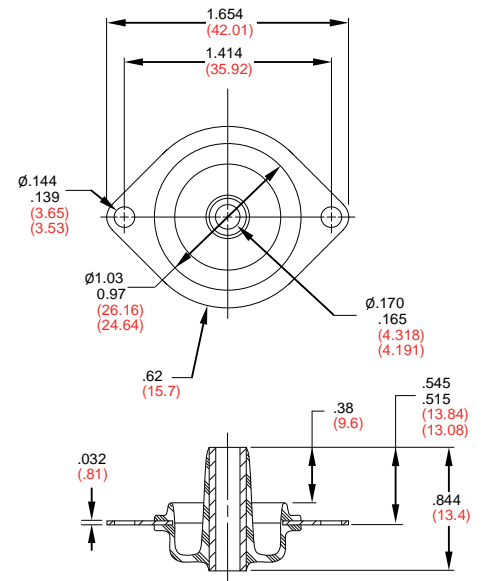

Metric values in parenthesis.

FIGURE 2 – TRANSMISSIBILITY VS. FREQUENCY

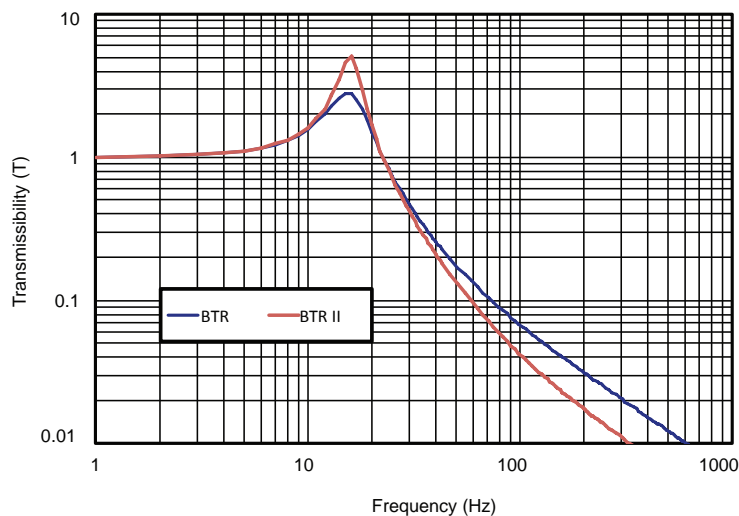

MULTIPLANE MOUNTS

156APL SERIES



- **Load capacity:**
3 to 8 lb (1.4 to 3.6 kg)

- **Materials:**
Metal parts and finish – aluminum alloy, chromate treated per MIL-DTL-5541, Class 1A
Inner member – 2024-T4 aluminum
Outer member – 2024-T3 or 2024-T4 aluminum
Elastomer – LORD BTR® or BTR® II Silicone

FIGURE 1 – PART DIMENSIONS

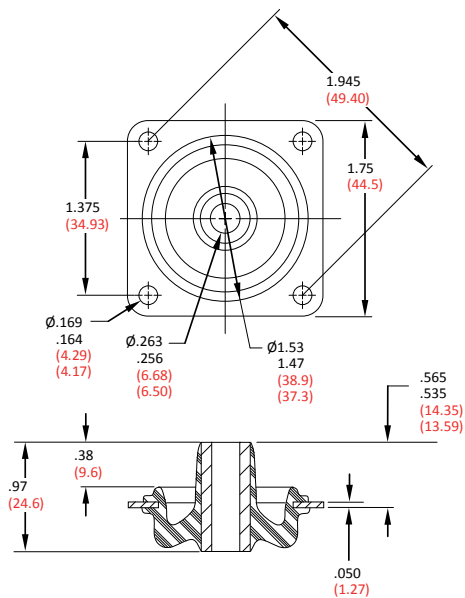

Metric values in parenthesis.

TABLE 1 – PERFORMANCE CHARACTERISTICS

Part Number	Static Load		Nominal Axial Natural Freq [†] (Hz)	Dynamic Axial Spring Rate [†]	
	lb	kg		lb/in	N/mm
156APL [*] -3	3	1.40	10	30	5.2
156APL [*] -4B	4.5	2.00	10	45	7.8
156APL [*] -6B	6.5	2.95	10	65	11
156APL [*] -8	8	3.60	10	80	14

When ordering, use the following in place of the ():

Q = BTR II elastomer

W = BTR elastomer

† At 0.036 in (0.91 mm) D.A. input and rated load.

TABLE 2 – SNUBBING WASHER DIMENSIONS

Part Number	Outside Diameter	Inside Diameter	Thickness
J-2049-1D			
in	1.38	0.26	0.05
mm	35.0	6.6	1.3

FIGURE 2 – TRANSMISSIBILITY VS. FREQUENCY

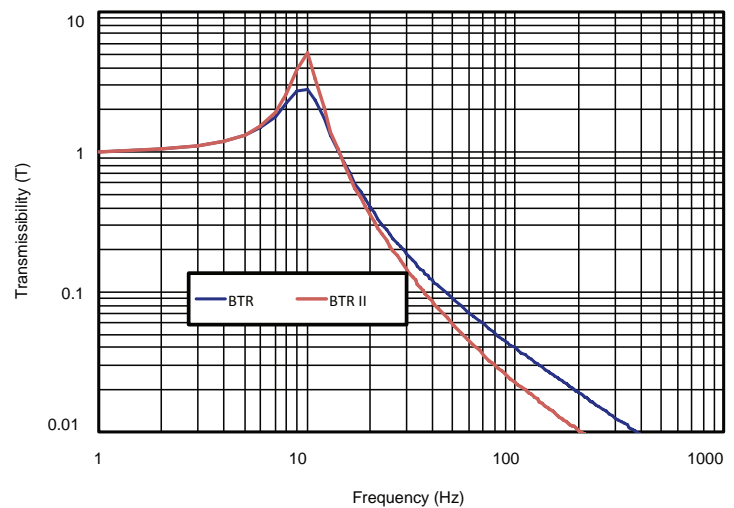

MULTIPLANE MOUNTS

156APDL SERIES



- **Load capacity:**
3 to 8 lb (1.4 to 3.6 kg)

- **Materials:**
Metal parts and finish – aluminum alloy, chromate treated per MIL-DTL-5541, Class 1A
Inner member – 2024-T4 aluminum
Outer member – 2024-T3 or 2024-T4 aluminum
Elastomer – LORD BTR® or BTR® II Silicone

TABLE 1 – PERFORMANCE CHARACTERISTICS

Part Number	Static Load		Nominal Axial Natural Freq [†] (Hz)	Dynamic Axial Spring Rate [†]	
	lb	kg		lb/in	N/mm
156APL*-3	3	1.40	10	30	5.2
156APL*-4B	4.5	2.00	10	45	7.8
156APL*-6B	6.5	2.95	10	65	11
156APL*-8	8	3.60	10	80	14

When ordering, use the following in place of the ():

Q = BTR II elastomer

W = BTR elastomer

† At 0.036 in (0.91 mm) D.A. input and rated load.

TABLE 2 – SNUBBING WASHER DIMENSIONS

Part Number J-2049-2D	Outside Diameter	Inside Diameter	Thickness
in	1.38	0.26	0.05
mm	35.0	6.6	1.3

FIGURE 2 – TRANSMISSIBILITY VS. FREQUENCY

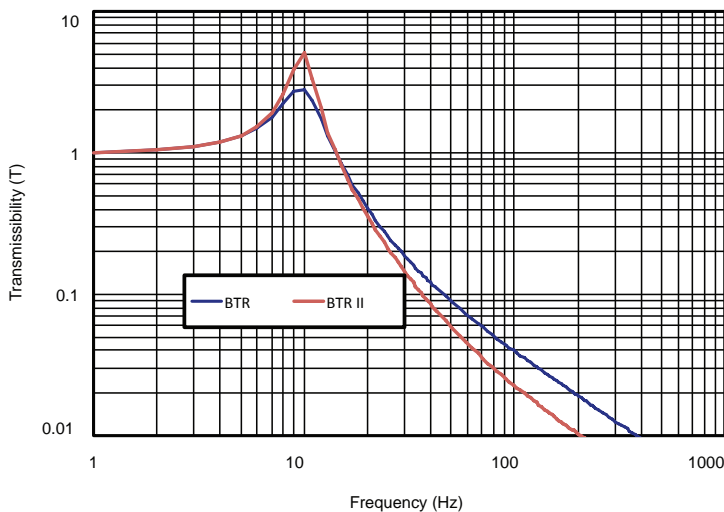
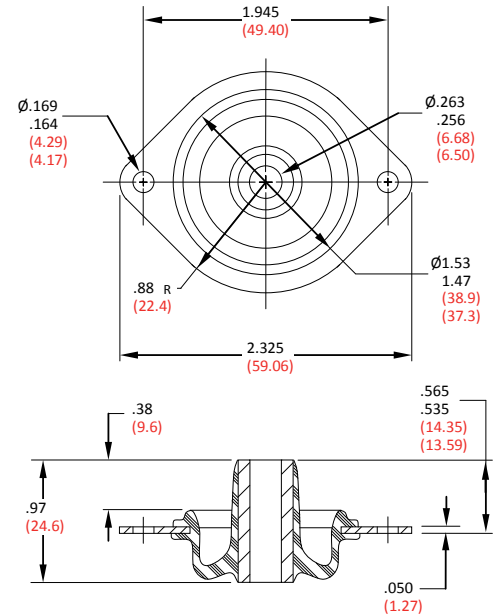

FIGURE 1 – PART DIMENSIONS



Metric values in parenthesis.

FIGURE 2 – TRANSMISSIBILITY VS. FREQUENCY

BTR[®] BROAD TEMPERATURE RANGE MOUNTS

HT SERIES

BTR[®] BROAD
TEMPERATURE
RANGE MOUNTS

BTR® BROAD TEMPERATURE RANGE MOUNTS

HT SERIES



PROVIDE EXCELLENT, ALL-ATTITUDE CONTROL OF VIBRATION AND RESISTANCE TO ENVIRONMENTAL EXTREMES

BTR® Broad Temperature Range Elastomer Mounts are vibration control isolators designed for protection of sensitive equipment exposed to severe dynamic conditions. Developed especially for critical applications and high performance aircraft, missile, spacecraft and vehicular environments, they are compact and highly efficient. The HT Series Mounts are suitable for all-attitude mounting systems that require natural frequencies above 20 Hz in the ambient temperature from -65°F to +300°F (-54°C to +149°C).

The excellent internal damping capability of BTR elastomer limits amplification at resonance to 3.5 or less under typical application conditions.

HT Mounts are available in four basic series: HT0, HT1, HT2 and HTC. Inverted designs with identical performance are available in the same corresponding series UT1 and UT2.

Their compactness permits designers to utilize internal suspension arrangements, eliminating the need for sway space outside the case.

BTR Mounts incorporate a reliable elastomer-to-metal bond in a mechanical safetied assembly. Repeat checks at 15g, 11ms, half-sine pulse inputs reveal no reduction in isolation efficiency. The mount withstands shock impulses of 30g, 11ms, half-sine pulse without failure.

Features:

- Resonant frequency and transmissibility are virtually constant from -65°F to +300°F (-54°C to +149°C)
- Amplification at resonance is 3.5 or less under typical conditions
- Mechanically safetied assembly incorporates a reliable elastomer-to-metal bond
- Inputs at resonance can be as high as 0.06 inch D.A.
- Efficiently isolates disturbing forces in all directions

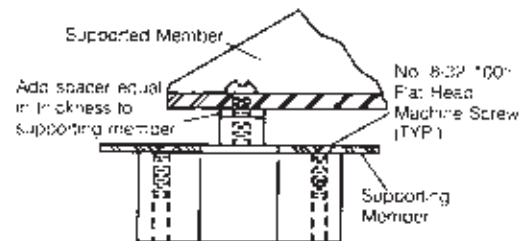
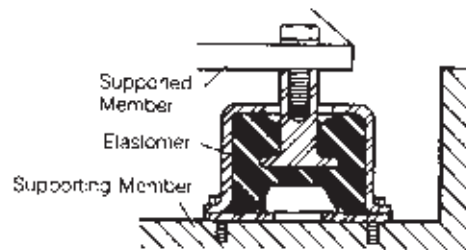

FIGURE 1 – TYPICAL INSTALLATION

BTR® BROAD TEMPERATURE RANGE MOUNTS

HT0 SERIES



- **Load capacity:**
1 to 7 lb (0.45 to 3.2 kg) per mount
- **Finish:**
Outer member – chromate treated per MIL-DTL-5541, Class 1A, outside gray lacquer paint (Ref. TT-L-32)
Inner member – chromate treated per MIL-DTL-5541, Class 1A
Washer – sulfuric acid anodized and dyed gray

- **Materials:**
Outer member – 380 aluminum or 6061-T6 aluminum
Inner member – 2024-T351 aluminum
Washer – 2024-T3 or 2024-T4 aluminum
Elastomer – LORD BTR® Silicone

FIGURE 1 – HT0 SERIES PART DIMENSIONS

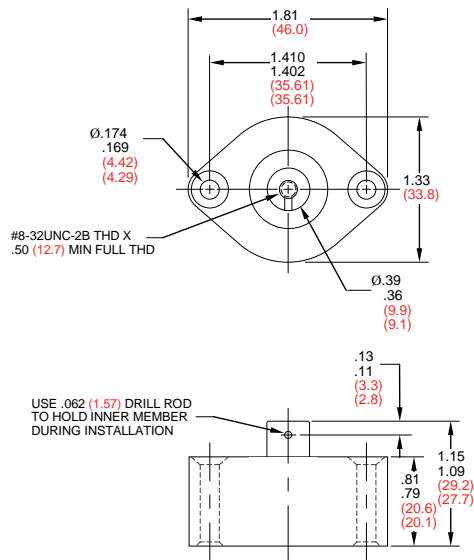

Metric values in parenthesis.

TABLE 1 – PERFORMANCE CHARACTERISTICS

Part Number	Max Static Load		Nominal Axial Natural Freq* – f_n (Hz)	Weight		Dynamic Axial Spring Rate*		Dynamic Radial Spring Rate*	
	lb	kg		oz	g	lb/in	N/mm	lb/in	N/mm
HT0-1	1	0.45	22	1.0	28	49	9	54	10
HT0-2	2	0.91	22	1.0	28	99	17	109	19
HT0-3	3	1.4	22	1.1	31	148	26	163	29
HT0-5	5	2.3	22	1.1	31	247	43	272	48
HT0-7	7	3.2	22	1.1	31	346	61	381	67

* At 0.036 in (0.91 mm) D.A. input and maximum static load.

To correct for loads below rated loads, use:

$$f_n = f_{nn} \sqrt{P_R/P_A}$$

where:

f_n = natural frequency at actual load

f_{nn} = nominal natural frequency

P_A = actual load

P_R = rated load

FIGURE 2 – TRANSMISSIBILITY VS. FREQUENCY

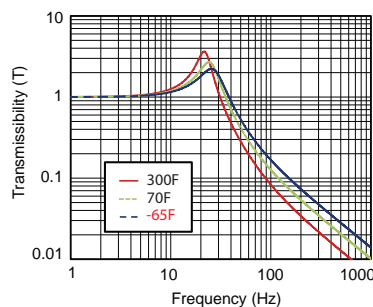
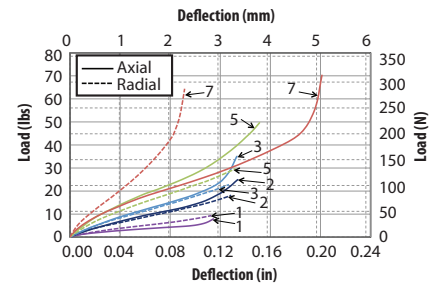

FIGURE 3 – LOAD VS. DEFLECTION



BTR® BROAD TEMPERATURE RANGE MOUNTS

HT1/UT1 SERIES



- **Load capacity:**
10 to 20 lb (4.5 to 9.1 kg) per mount
- **Finish:**
Outer member – chromate treated per MIL-DTL-5541, Class 1A, outside gray lacquer paint (Ref. TT-L-32)
Inner member – chromate treated per MIL-DTL-5541, Class 1A
Washer – sulfuric acid anodized and dyed gray

- **Materials:**
Outer member – 6061-T6 aluminum alloy
Inner member – 2024-T4 or 2024-T351 aluminum alloy
Washer – 2024-T3 or 2024-T4 aluminum alloy
Elastomer – LORD BTR® Silicone

TABLE 1 – PERFORMANCE CHARACTERISTICS

Part Number	Max Static Load		Nominal Axial Natural Freq* – f_n (Hz)	Weight		Dynamic Axial Spring Rate*		Dynamic Radial Spring Rate*	
	lb	kg		oz	g	lb/in	N/mm	lb/in	N/mm
HT1-10	10	4.5	22	2.5	71	494	86	445	78
UT1-10									
HT1-15	15	6.8	22	2.6	74	741	130	667	117
UT1-15									
HT1-20	20	9.1	22	2.7	77	988	173	889	156
UT1-20									

* At 0.036 in (0.91 mm) D.A. input and maximum static load.

To correct for loads below rated loads, use:

$$f_n = f_{nn} \sqrt{P_R / P_A}$$

where:

f_n = natural frequency at actual load

f_{nn} = nominal natural frequency

P_A = actual load

P_R = rated load

FIGURE 3 – TRANSMISSIBILITY VS. FREQUENCY

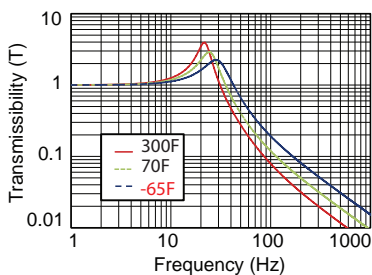

FIGURE 4 – LOAD VS. DEFLECTION

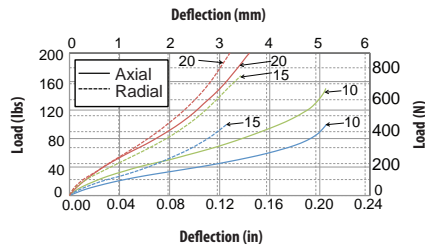
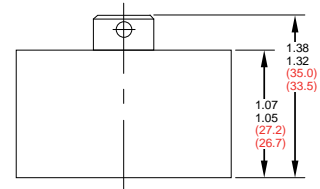
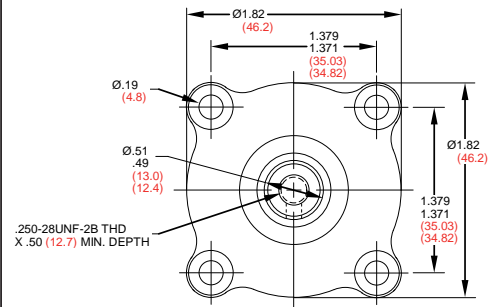
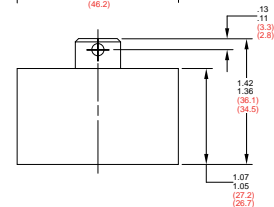
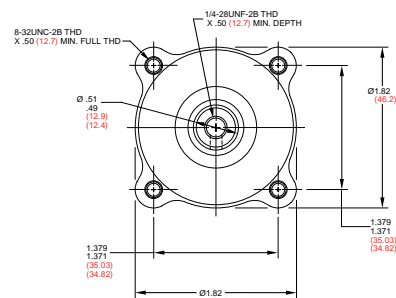

FIGURE 1 – HT1 SERIES PART DIMENSIONS



Metric values in parenthesis.

FIGURE 2 – UT1 SERIES PART DIMENSIONS



Metric values in parenthesis.

BTR[®] BROAD TEMPERATURE RANGE MOUNTS

HT2/UT2 SERIES



- **Load capacity:**
23 to 100 lb (10.5 to 45 kg) per mount
- **Finish:**
Outer member – sulfuric acid anodized and dyed gray
Inner member – chromate treated per MIL-DTL-5541, Class 1A
Inner member (HT2-100 & UT2-100 only) – CAD plated
Bottom Plate – sulfuric acid anodized and dyed gray

- **Materials:**
Outer member – 6061-0 aluminum alloy
Inner member – 2024-T351 aluminum
Inner member (HT2-100 & UT2-100 only) – 12L14 C.R. steel
Bottom Plate – 2024-T3 aluminum alloy
Elastomer – LORD BTR[®] Silicone

FIGURE 1 – HT2 SERIES PART DIMENSIONS

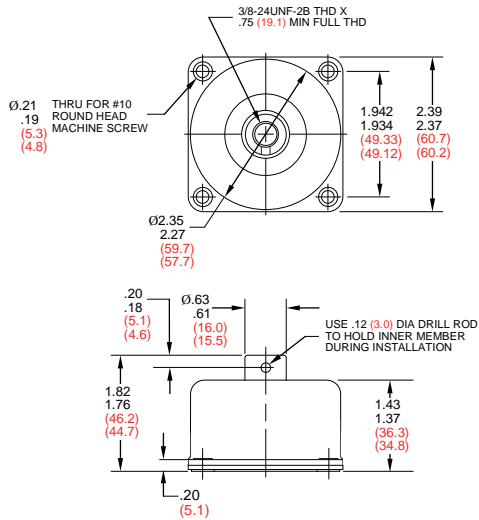

Metric values in parenthesis.

FIGURE 2 – UT2 SERIES PART DIMENSIONS

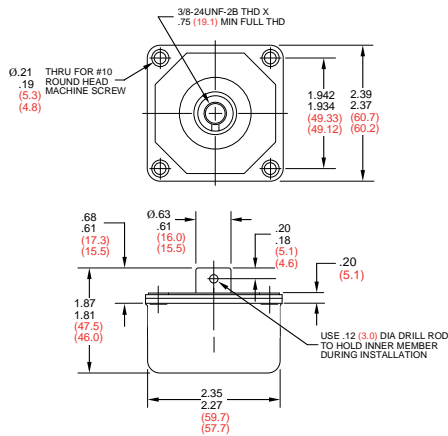

Metric values in parenthesis.

TABLE 1 – PERFORMANCE CHARACTERISTICS

Part Number	Max Static Load		Nominal Axial Natural Freq – f_n (Hz)	Weight		Dynamic Axial Spring Rate		Dynamic Radial Spring Rate	
	lb	kg		oz	g	lb/in	N/mm	lb/in	N/mm
HT2-23	23	10.4	20*	4.5	128	939	164	845	148
UT2-23									
HT2-35	35	15.8	20*	4.7	133	1428	250	1285	225
UT2-35									
HT2-50	50	22.7	20*	5.3	150	2041	357	1837	321
UT2-50									
HT2-80	80	36.3	20*	5.6	159	3265	571	2938	514
UT2-80									
HT2-100	100	45.4	21**	5.6	159	4500	788	4050	709
UT2-100									

* At 0.060 in (1.52 mm) D.A. input and maximum static load.

** At 0.036 in (0.91 mm) D.A. input and maximum static load.

To correct for loads below rated loads, use:

$$f_n = f_{nn} \sqrt{P_R/P_A}$$

where:

f_n = natural frequency at actual load

f_{nn} = nominal natural frequency

P_A = actual load

P_R = rated load

FIGURE 3 – TRANSMISSIBILITY VS. FREQUENCY

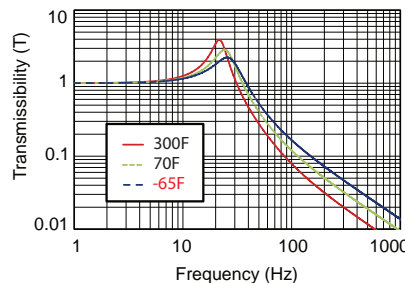
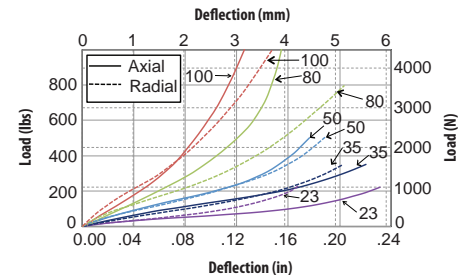

FIGURE 4 – LOAD VS. DEFLECTION



BTR® BROAD TEMPERATURE RANGE MOUNTS

HTC SERIES



- **Load capacity:**
110 to 150 lb (50 to 68 kg) per mount
- **Finish:**
Outer member – sulfuric acid anodized and dyed gray
Inner member – chromate treated per MIL-DTL-5541, Class 1A
Bottom Plate – sulfuric acid anodized and dyed gray

- **Materials:**
Outer member – 2024-T351 aluminum alloy
Inner member – 2024-T351 aluminum alloy
Bottom Plate – 5052-0 aluminum alloy or 360.0 aluminum alloy casting
Elastomer – LORD BTR® Silicone

TABLE 1 – PERFORMANCE CHARACTERISTICS

Part Number	Max Static Load		Nominal Axial Natural Freq* – f_n (Hz)	Weight		Dynamic Axial Spring Rate*		Dynamic Radial Spring Rate*	
	lb	kg		oz	g	lb/in	N/mm	lb/in	N/mm
HTC-110	110	50	20	14.0	397	4490	786	5388	943
HTC-150	150	68	20	14.2	408	6122	1071	7346	1286

* At 0.036 in (0.91 mm) D.A. input and maximum static load.

To correct for loads below rated loads, use:

$$f_n = f_{nm} \sqrt{P_R / P_A}$$

where:

f_n = natural frequency at actual load

f_{nm} = nominal natural frequency

P_A = actual load

P_R = rated load

FIGURE 1 – HTC SERIES PART DIMENSIONS

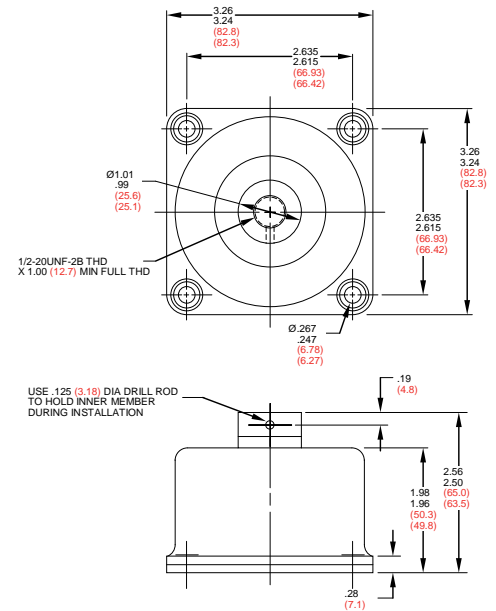

Metric values in parenthesis.

FIGURE 2 – TRANSMISSIBILITY VS. FREQUENCY

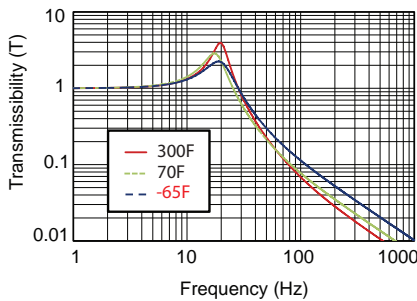
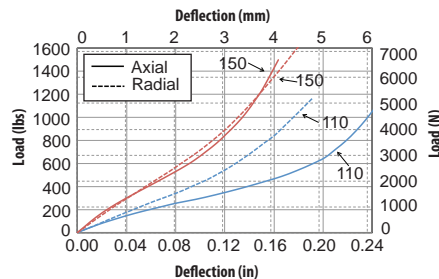

FIGURE 3 – LOAD VS. DEFLECTION



PEDESTAL MOUNTS

PS SERIES

PEDESTAL
MOUNTS

PEDESTAL MOUNTS

PS SERIES

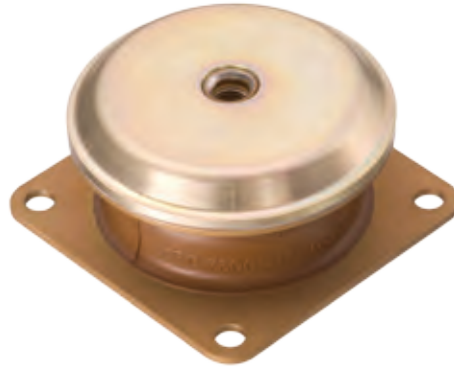

NEW HIGHLY DAMPED ELASTOMERIC ISOLATORS

Designed to protect delicate electronic equipment from damaging shock and vibration, these isolators are widely used in jet aircraft, missile, spacecraft and related ground support equipment. The low-profile design requires a minimum of headroom. Installation is simple; no special openings or tools are needed. Bonded in BTR® elastomer, these mounts have high damping and wide operating temperature range.

Features:

- Rated load range: 8 to 60 lb (3.6 to 27 kg)
- Maximum amplification at resonance: 2.5 to 4, depending on vibration environment
- Operating temperature range: -65°F to +300°F (-54°C to +149°C)
- Gradual snubbing under shock load
- Accommodate vibratory inputs up to 0.06 inch D.A.
- Sustain a 15g, 11ms, half-sine shock pulse without significant change in performance and a 30g, 11ms, half-sine pulse without failure

Benefits:

- Fully bonded: precise, predictable and reliable performance over a wide range of vibration disturbances
- All-attitude performance: axial and radial static and dynamic characteristics nearly the same, can be loaded in any direction
- Fail safe: mechanical interlock keeps equipment in place in the event of elastomeric failure

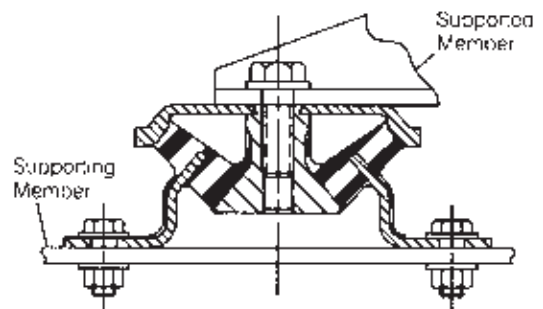
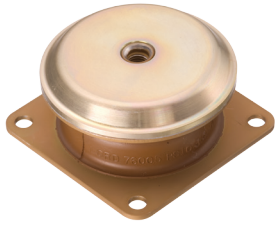

FIGURE 1 – TYPICAL INSTALLATION

PEDESTAL MOUNTS

PS SERIES



- **Load capacity:**
8 to 50 lb (3.6 to 27 kg)
- **Mount weight for all variations:**
3.0 oz (85 g) max

- **Materials:**
Metal parts and finish – aluminum alloy, chromate treated per MIL-DTL-5541, Class 1A
Inner member – 2024-T3 aluminum
Other metal parts – 2024-T3 aluminum

FIGURE 1 – PART DIMENSIONS

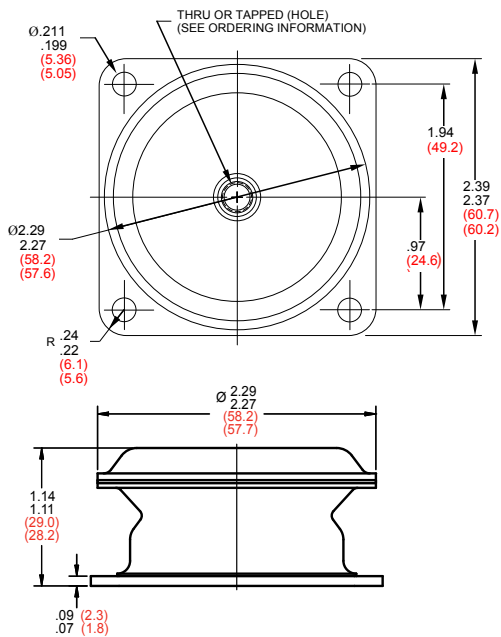

Metric values in parenthesis.

FIGURE 2 – LOAD VS. DEFLECTION

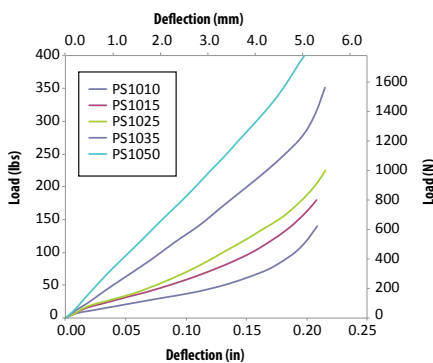

TABLE 1 – PERFORMANCE CHARACTERISTICS

Part Number	Load Range		Nominal Dynamic Axial Frequency - f_n (Hz)	Dynamic Axial Spring Rate		Dynamic Radial Spring Rate	
	lb	kg		lb/in	N/mm	lb/in	N/mm
PS1010	8-12	3.6-5.4	25	638	112	638	112
PS1015	13-19	5.9-8.6	25	957	167	957	167
PS1025	20-28	9.1-13	25	1595	279	1595	279
PS1035	29-41	13-19	25	2233	391	2233	391
PS1050	42-50	19-27	25	3190	558	3190	558

Ordering Information:

Although aluminum components are considered standard, pedestal mounts with steel components may also be ordered. A suffix letter "A" designates aluminum and letter "S" designates steel.

All variations of pedestal mount are available with either a through hole or a tapped hole in the center of the mount. The standard size is 1/4 in (6.35 mm). The type of hole is indicated by a suffix.

Explanation of part numbering system:

P S 10 15 - A - 8

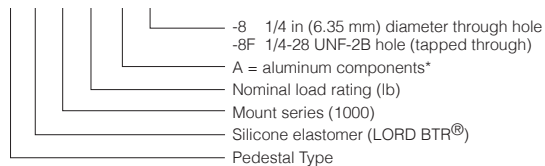

* Other materials available as specials only.

FIGURE 3 – TRANSMISSIBILITY VS. FREQUENCY

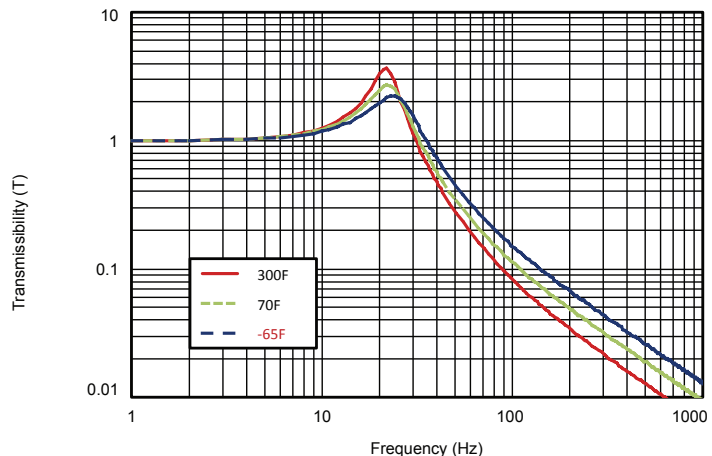

NOTES

Lined area for taking notes, consisting of 24 horizontal lines.

HIGH DEFLECTION MOUNTS

HDM SERIES | MHDM SERIES

HIGH DEFLECTION
MOUNTS

HIGH DEFLECTION MOUNTS

HDM SERIES, MHDM SERIES



ALL-ATTITUDE SHOCK PROTECTION COMBINED WITH SUPERIOR VIBRATION CONTROL

The HDM Mount and MHDM Mount are ideal for a variety of shock protection applications. HDM Mounts are capable of deflecting 0.75 inches in both the axial and radial directions under a shock load. Both designs also provide isolation when high amplitude vibration excitation is expected. While supporting the rated load, the HDM Mount will attenuate a 15g, 11ms, half-sine pulse to 10g and 30g, 11ms, half-sine pulse to 16g.

The HDM Mount is available in LORD BTR® silicone and SPE® I elastomers to suit a variety of applications. The BTR silicone has excellent damping characteristics as well as Broad Temperature Range performance characteristics from -65°F to +300°F (-54°C to +149°C). LORD SPE I has good damping characteristics and is suitable for environments ranging from -65°F to +165°F (-54°C to +74°C).

HIGH DEFLECTION MOUNTS

HDM SERIES



- **Static load per mount:**
12 to 50 lb (5.5 to 23 kg)
- **Maximum dynamic input at resonance:**
0.125 in D.A.
- **Natural frequency:**
20 to 25 Hz at 0.036 in (0.91 mm) D.A. and rated load
- **Weight:**
8.8 oz (250 g)

• **Materials:**

Metal parts and finish – aluminum alloy, chromate treated per MIL-DTL-5541, Class 1A
 Inner member – 6061-T651 aluminum
 Outer member – 6061-T6 aluminum
 Elastomer – LORD BTR® Silicone or SPE® I Natural Rubber Blend

FIGURE 1 – PART DIMENSIONS

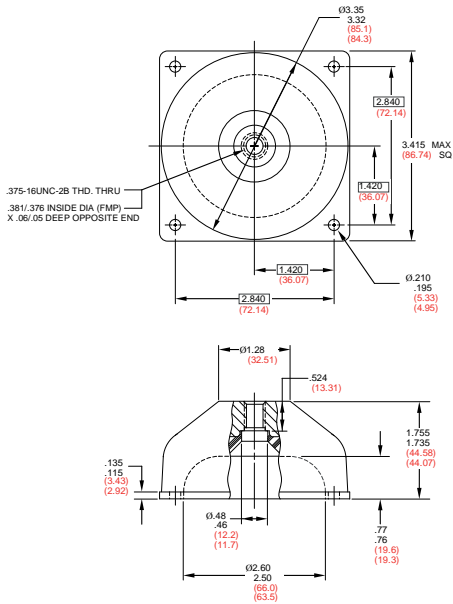

Metric values in parenthesis.

FIGURE 2 – TRANSMISSIBILITY VS. FREQUENCY

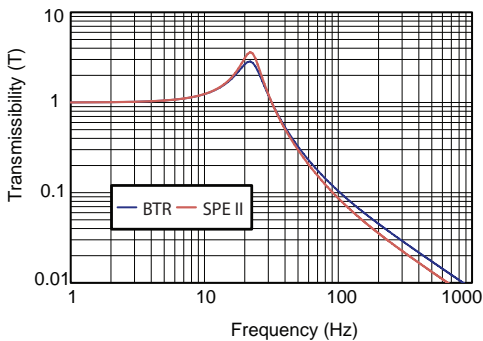
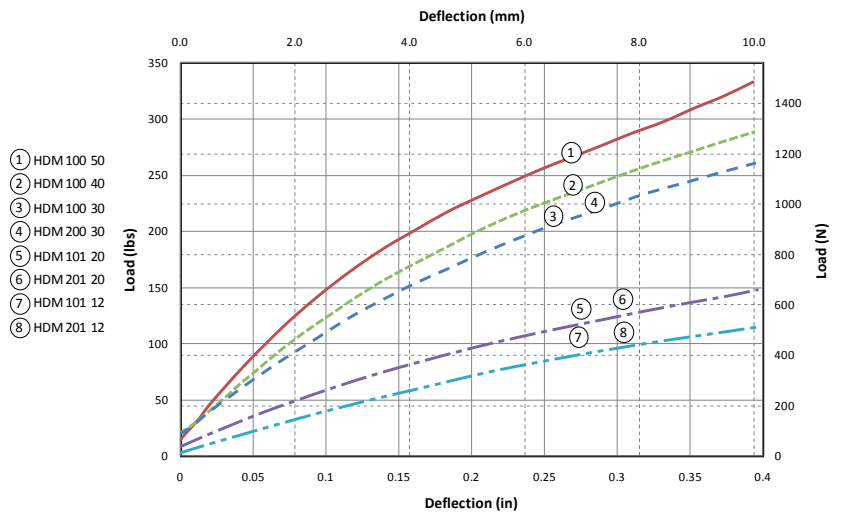

TABLE 1 – PERFORMANCE CHARACTERISTICS

Part Number	Load Rating		Dynamic Axial Spring Rate*		Dynamic Radial Spring Rate*		Maximum Transmissibility
	lb	kg	lb/in	N/mm	lb/in	N/mm	
BTR							
HDM 201 12	12	5.5	620	109	517	91	3.5
HDM 201 20	20	9.1	1033	181	861	151	3.5
HDM 200 30	30	14	1550	272	1107	194	3.5
SPE I							
HDM 101 12	12	5.5	620	109	517	91	7
HDM 101 20	20	9.1	1033	181	861	151	6
HDM 100 30	30	14	1550	272	1107	194	5
HDM 100 40	40	18	2067	362	1292	226	5
HDM 100 50	50	23	2584	453	1615	283	5

* Dynamic input = 0.036 in (0.91 mm) D.A.

FIGURE 3 – LOAD VS. DEFLECTION



HIGH DEFLECTION MOUNTS

MHDM SERIES



- **Load capacity:**
2 to 6 lb (0.91 to 2.7 kg)
- **Maximum dynamic input at resonance:**
0.12 in D.A.
- **Weight:**
2.05 oz (58g)

- **Materials:**

Inner member – 2024-T351 aluminum alloy, chromate treated per MIL-DTL-5541, Class 1A

Outer member – 204-T3 or 2024-T351 aluminum, chromate treated per MIL-DTL-5541, Class 1A

Elastomer – LORD BTR® Silicone

TABLE 1 – PERFORMANCE CHARACTERISTICS

Part Number	Load Rating		Dynamic Axial Spring Rate		Natural Frequency (Hz)
	lb	kg	lb/in	N/mm	
MHDM-201-2	2	0.91	100	17.5	22
MHDM-201-4	4	1.8	200	35	22
MHDM-201-6	6	2.7	300	52.5	22

FIGURE 1 – PART DIMENSIONS

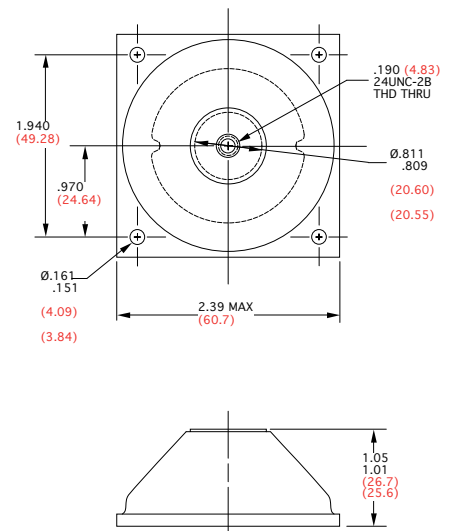

Metric values in parenthesis.

FIGURE 2 – TRANSMISSIBILITY VS. FREQUENCY

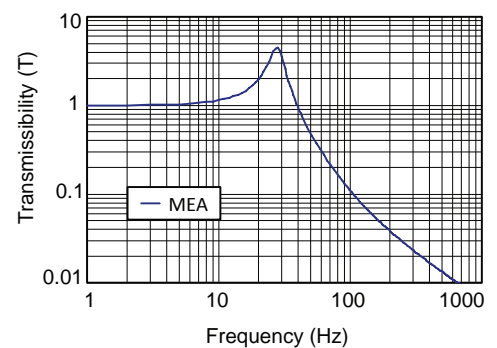

SHIPPING CONTAINER MOUNTS

J-18100 SERIES

SHIPPING
CONTAINER
MOUNTS

SHIPPING CONTAINER MOUNTS

J-18100 SERIES



FOR PROTECTING PRODUCTS IN TRANSIT – SANDWICH MOUNTS WITH SPE® I ELASTOMER

The LORD series of Shipping Container Mounts are for fragile, valuable products needing predictable, low to medium level protection. Bonded elastomeric sandwich mounts are simple, versatile, economical and easy to install.

These Shipping Container Mounts consist of two metal plates with an elastomer bonded between them. The composition and configuration of the elastomer determines the static and dynamic properties of the part. Sandwich mounts have excellent capacity for energy control, and they exhibit linear shear load deflection characteristics through a significant deflection range.

Offering controlled stiffness in all directions, a rugged one-piece bonded assembly and long service life, they are reusable for years, even under severe shipping conditions.

LORD offers standard Shipping Container Mounts with or without corrosion resistant paint. Standardization includes both elastomer and hardware. Seven different series of parts give you a wide choice of sizes, load capacities and spring rates.

Shipping Container Mounts are made with SPE® I elastomer, a broad-temperature range stock and meet the rigid requirements of military packaging specifications over the entire operational temperature spectrum from -65°F to +165°F (-54°C to +74°C). Low carbon steel metal components are painted for corrosion protection. If paint is not required, they are treated with a rust preventative.

Shipping Container Mounts are designed to meet dynamic load requirements. Drop tests are conducted to determine the energy-absorbing characteristics under specified environmental conditions. Mounts are subject to severe fatigue tests to determine expected life. Still other tests are run to determine dynamic natural frequency, damping values and fatigue life under vibratory conditions.

SHIPPING CONTAINER MOUNTS

J-18100 SERIES

FIGURE 1 – J-18100 PART DIMENSIONS

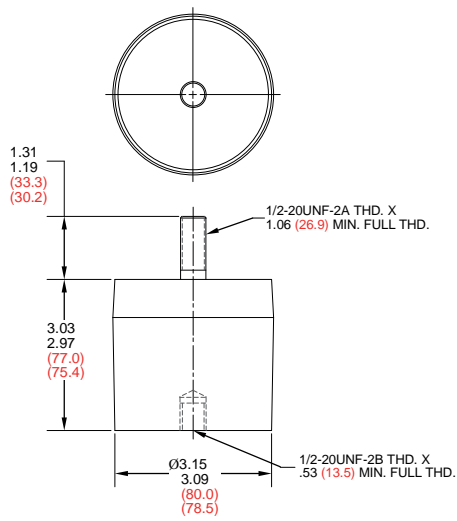

Metric values in parenthesis.



TABLE 1 – J-18100 PERFORMANCE CHARACTERISTICS

Part Number		Shear Ratings					
		Spring Rate		Maximum Load		Maximum Deflection	
Painted	Unpainted	lb/in	N/mm	lb	kg	in	mm
J-18100-2	J-18100-12	210	37	80	36	6.5	165
J-18100-3	J-18100-13	235	41	90	41	6.2	157
J-18100-4	J-18100-14	265	46	100	45	5.5	140
J-18100-5	J-18100-15	300	53	115	52	4.9	124
J-18100-6	J-18100-16	355	62	135	61	4.1	104
J-18100-7	J-18100-17	395	69	155	70	3.7	94

Ratio of compression to shear spring rate of mount (L value) = 6.5 (approx.) for this series.

J-18101 SERIES

FIGURE 2 – J-18101 PART DIMENSIONS

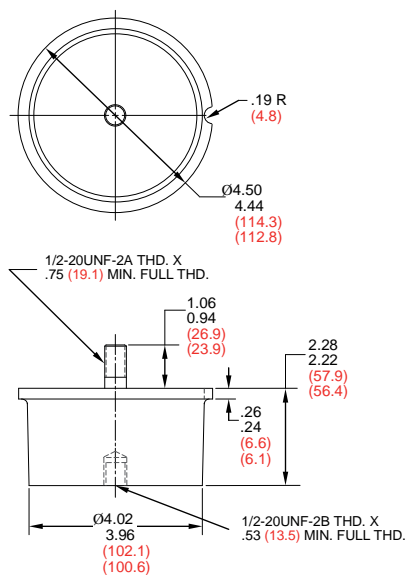

Metric values in parenthesis.



TABLE 2 – J-18101 PERFORMANCE CHARACTERISTICS

Part Number		Shear Ratings					
		Spring Rate		Maximum Load		Maximum Deflection	
Painted	Unpainted	lb/in	N/mm	lb	kg	in	mm
J-18101-2	J-18101-12	525	96	205	93	4.6	117
J-18101-3	J-18101-13	570	100	220	100	4.2	107
J-18101-4	J-18101-14	605	106	235	107	4.0	102
J-18101-5	J-18101-15	675	118	265	120	3.6	91
J-18101-6	J-18101-16	875	153	310	141	2.7	69
J-18101-7	J-18101-17	965	169	310	141	2.5	64

Ratio of compression to shear spring rate of mount (L value) = 8 (approx.) for this series.

SHIPPING CONTAINER MOUNTS

J-18102 SERIES

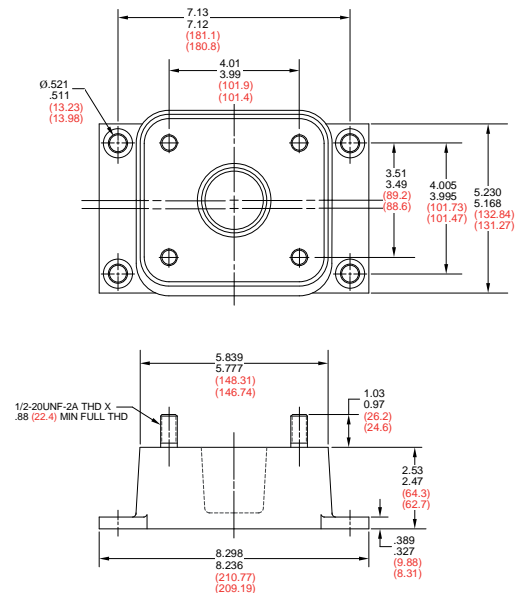

TABLE 3 – J-18102 PERFORMANCE CHARACTERISTICS

Part Number		Shear Ratings					
		Spring Rate		Maximum Load		Maximum Deflection	
Painted	Unpainted	lb/in	N/mm	lb	kg	in	mm
		J-18102-2	J-18102-12	1060	188	415	189
J-18102-3	J-18102-13	1295	227	505	230	4.0	102
J-18102-4	J-18102-14	1420	249	555	252	3.7	94
J-18102-5	J-18102-15	1680	294	655	298	3.1	79
J-18102-6	J-18102-16	2130	373	680	309	2.4	61
J-18102-7	J-18102-17	2435	427	680	309	2.1	53

Ratio of compression to shear spring rate of mount (L value) = 12 (approx.) for this series.

FIGURE 3 – J-18102 PART DIMENSIONS



Metric values in parenthesis.

J-18103 SERIES

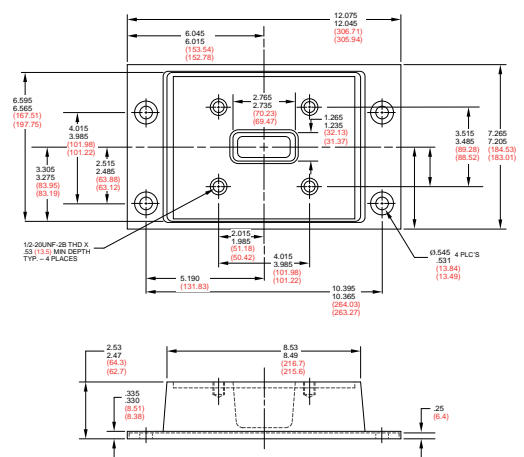

TABLE 4 – J-18103 PERFORMANCE CHARACTERISTICS

Part Number		Shear Ratings					
		Spring Rate		Maximum Load		Maximum Deflection	
Painted	Unpainted	lb/in	N/mm	lb	kg	in	mm
		J-18103-2	J-18103-12	2165	379	850	386
J-18103-3	J-18103-13	2425	425	950	432	4.1	104
J-18103-4	J-18103-14	2765	484	1080	491	3.6	91
J-18103-5	J-18103-15	3245	569	1270	577	3.1	79
J-18103-6	J-18103-16	3540	620	1310	595	2.8	71
J-18103-7	J-18103-17	3880	680	1310	595	2.6	66

Ratio of compression to shear spring rate of mount (L value) = 9 (approx.) for this series.

FIGURE 4 – J-18103 PART DIMENSIONS



Metric values in parenthesis.

SHIPPING CONTAINER MOUNTS

J-18104 SERIES

FIGURE 5 – J-18104 PART DIMENSIONS

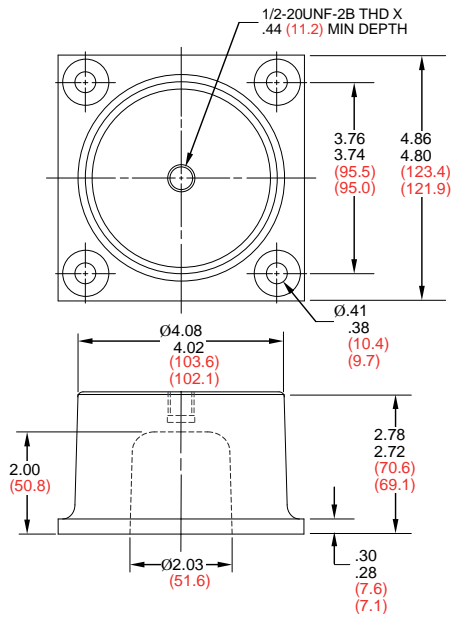

Metric values in parenthesis.



TABLE 5 – J-18104 PERFORMANCE CHARACTERISTICS

Part Number		Shear Ratings					
		Spring Rate		Maximum Load		Maximum Deflection	
Painted	Unpainted	lb/in	N/mm	lb	kg	in	mm
J-18104-2	J-18104-12	290	51	110	50	5.9	150
J-18104-3	J-18104-13	310	54	120	55	5.9	150
J-18104-4	J-18104-14	365	64	140	64	5.1	130
J-18104-5	J-18104-15	410	72	160	73	4.5	114
J-18104-6	J-18104-16	525	92	205	93	3.5	89
J-18104-7	J-18104-17	575	101	225	102	3.2	81

Ratio of compression to shear spring rate of mount (L value) = 6 (approx.) for this series.

J-18105 SERIES

FIGURE 6 – J-18105 PART DIMENSIONS

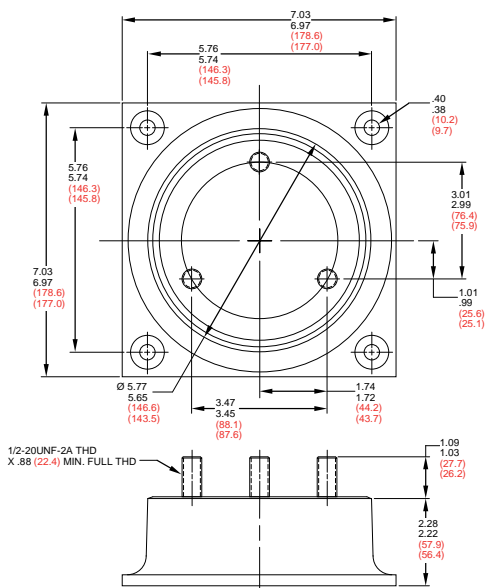

Metric values in parenthesis.



TABLE 6 – J-18105 PERFORMANCE CHARACTERISTICS

Part Number		Shear Ratings					
		Spring Rate		Maximum Load		Maximum Deflection	
Painted	Unpainted	lb/in	N/mm	lb	kg	in	mm
J-18105-2	J-18105-12	750	131	290	132	4.6	117
J-18105-3	J-18105-13	815	143	320	149	4.3	109
J-18105-4	J-18105-14	890	156	350	159	3.9	99
J-18105-5	J-18105-15	1000	175	390	177	3.4	86
J-18105-6	J-18105-16	1150	201	450	205	3.0	76
J-18105-7	J-18105-17	1275	233	450	205	2.7	69

Ratio of compression to shear spring rate of mount (L value) = 8 (approx.) for this series.

SHIPPING CONTAINER MOUNTS

J-18106 SERIES

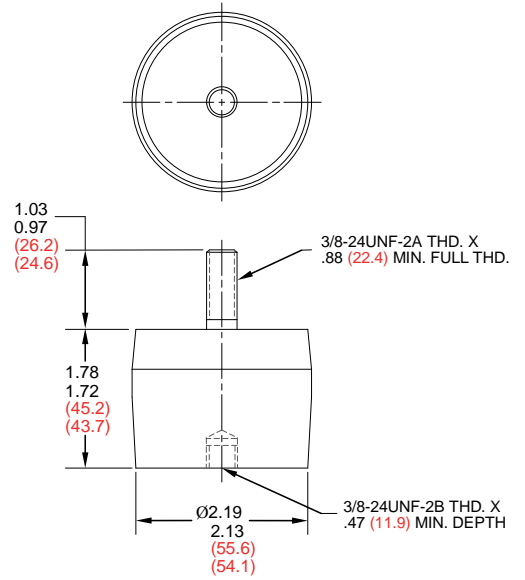

TABLE 7 – J-18106 PERFORMANCE CHARACTERISTICS

Part Number		Shear Ratings					
		Spring Rate		Maximum Load		Maximum Deflection	
Painted	Unpainted	lb/in	N/mm	lb	kg	in	mm
J-18106-2	J-18106-12	155	27	55	25	3.4	86
J-18106-3	J-18106-13	180	32	60	27	3.4	86
J-18106-4	J-18106-14	215	38	75	34	3.3	84
J-18106-5	J-18106-15	240	42	80	36	2.9	74
J-18106-6	J-18106-16	320	56	90	41	2.2	56
J-18106-7	J-18106-17	350	61	90	41	2.0	51

Ratio of compression to shear spring rate of mount (L value) = 11 (approx.) for this series.

FIGURE 7 – J-18106 PART DIMENSIONS



Metric values in parenthesis.

INTERIOR ISOLATORS

SIDEWALL PANEL | FLOOR PANEL | CLOSE-OUT PANEL |
ROD ENDS | GROMMETS

INTERIOR ISOLATORS

SIDEWALL PANEL, FLOOR PANEL, CLOSE-OUT PANEL, ROD ENDS, GROMMETS



A COMPLETE 360 DEGREE SOLUTION TO AN AIRCRAFT'S INTERIOR NOISE AND VIBRATION CHALLENGES

LORD approaches each project with the same process: strive to offer a 360 degree solution and try to isolate all the surfaces in the passenger cabin. Highlighted here are mounts that are particularly good for aircraft interior applications including sidewall panels, floor panels, close-out panels, rod ends and grommets. The performance of these parts will focus on attenuating the noise paths to the passenger by isolating discrete attach points in panels, bulkheads, windows, etc.

Some of the benefits of LORD interior mounts are their compact geometry, lightweight materials, failsafe designs and the quick installing snap-in and thread locking features. Also included with some of the parts is LORD proprietary silicone elastomer providing incredible cold temperature performance while meeting flame, smoke and toxicity requirements.

Also available to customers in the earlier stages of designing an aircraft is the LORD engineering staff that can work with an aircraft OEM to achieve better cabin acoustics. Through years of isolation experience, LORD has come up with guidelines to achieve a quieter cabin. Please contact LORD at +1 877 ASK LORD (275 5673) for more information.

INTERIOR ISOLATORS

SIDEWALL PANEL ISOLATORS



- **Maximum rated load per mount:**
4 to 8 lb (1.8 to 3.6 kg)

- **Weight:**
J-23644-3 – 0.39 oz (11 g)
J-23767-1 – 0.21 oz (6 g)
J-23676-2 – 0.42 oz (11.9 g)

- **Materials:**

Inner member – 304 stainless steel, passivated

Outer member – 6061-T6 or 6061-T6511 aluminum alloy, chromate conversion coated per MIL-C-5541, Class 1A

Elastomer – Silicone

**FIGURE 1 – J-23644-3
PART DIMENSIONS**

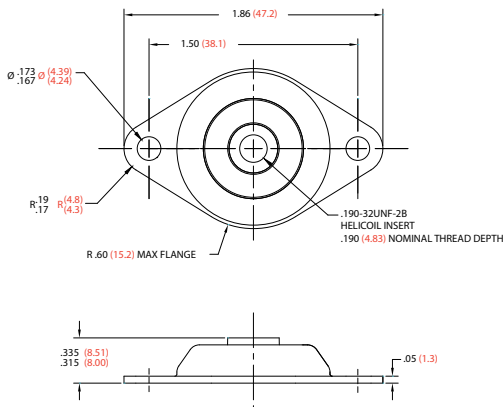

Metric values in parenthesis.

**FIGURE 2 – J-23676-1
PART DIMENSIONS**

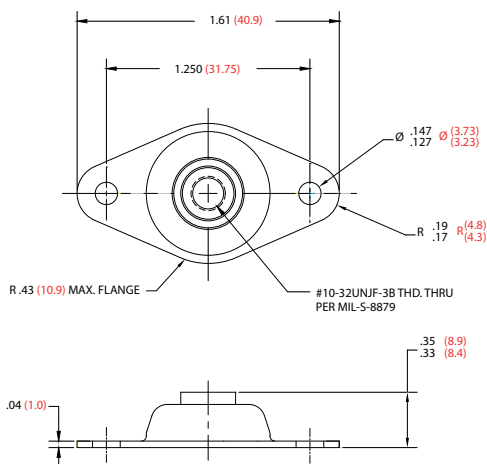

Metric values in parenthesis.

TABLE 1 – PERFORMANCE CHARACTERISTICS

Part Number	Load Rating		Dynamic Axial Spring Rate*		Natural Frequency (Hz)*
	lb	kg	lb/in	N/mm	
J-23644-3	7.5	3.4	700	120	30
J-23676-1	4	1.8	500	87.7	35
J-23676-2	8	3.6	1000	175.4	35

* At 0.002 in (0.05 mm) D.A. input and rated load.

FIGURE 3 – J-23676-2 PART DIMENSIONS

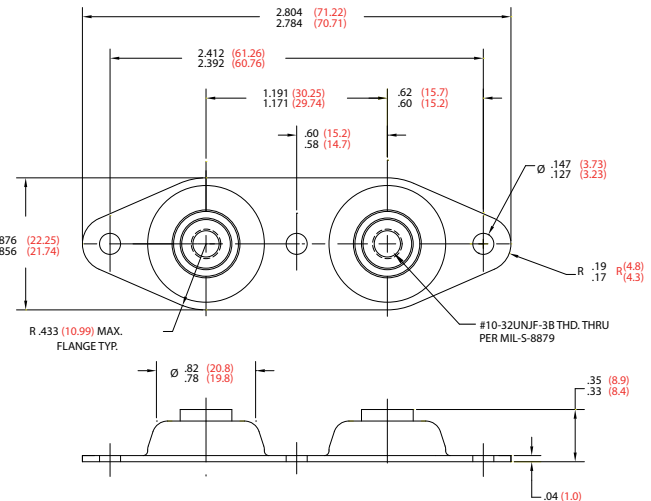

Metric values in parenthesis.

INTERIOR ISOLATORS

FLOOR PANEL - J-23436 SERIES



- **Maximum rated load per mount:**
1 lb (0.45 kg)
- **Weight:**
J-23436-7 – 0.31 oz (8.7 g)
J-23436-8 – 0.27 oz (7.65 g)

- **Materials:**
Inner Member – 6061 aluminum alloy, anodized
Housing – J-23436-7 – 6061-T6 aluminum alloy, anodized;
J-23436-8 – high strength thermoplastic, glass reinforced
Retaining Cap (J-23436-8 only) – high strength thermoplastic, glass reinforced
Elastomer – NR

TABLE 1 – PERFORMANCE CHARACTERISTICS

Part Number	Dynamic Axial Spring Rate		Dynamic Radial Spring Rate*	
	lb/in	N/mm	lb/in	N/mm
J-23436-7	489	86	1700	298
J-23436-8	489	86	2000	351

* At 120 Hz with ±.001 in (0.025 mm) input.

Snap-in design accomodating variable panel thickness. No tool required.

These isolators work ideally with aerospace potting epoxy LORD-309GB which is available in bulk, or in various pre-mix commercial packages.

FIGURE 1 – J-23436-7 PART DIMENSIONS

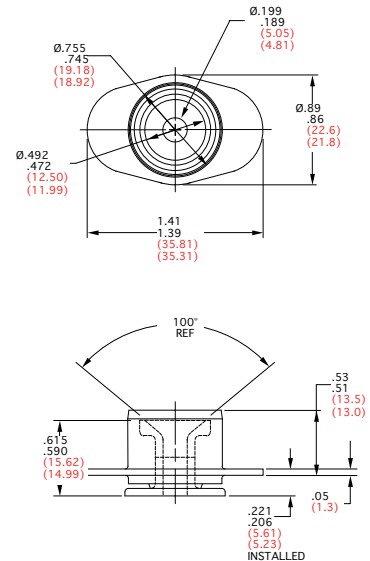

Mechanical stake in 0.40 panel thickness, tool required.

Metric values in parenthesis.

FIGURE 2 – J-23436-8 PART DIMENSIONS

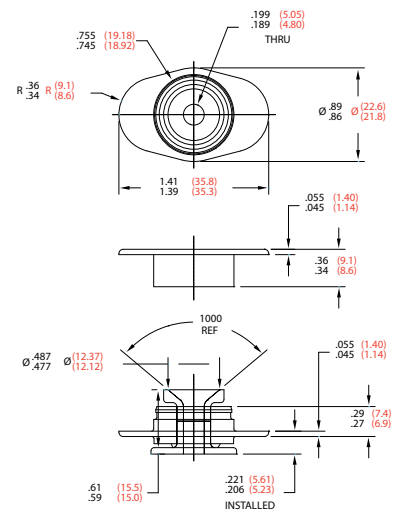

Metric values in parenthesis.

INTERIOR ISOLATORS

CLOSE-OUT PANEL - J-7444 SERIES



- **Maximum rated load per mount:**
2 lb (0.91 kg)
- **Weight:**
0.20 oz (5.7 g)

- **Materials:**
Base plate – 2024-T3 aluminum alloy, chromate treated per MIL-C-5541, Class 1A
Lock plate – 17-7PH stainless steel, passivated
Elastomer – Silicone

FIGURE 1 – PART DIMENSIONS

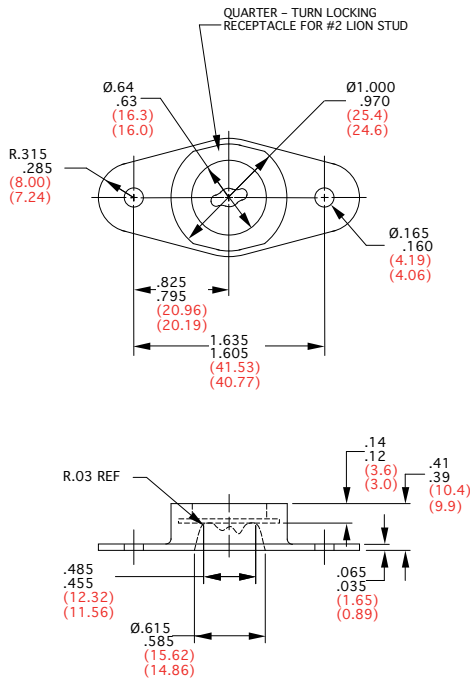

Metric values in parenthesis.

TABLE 1 – PERFORMANCE CHARACTERISTICS

Part Number	Dynamic Axial Spring Rate	
	lb/in	N/mm
J-7444-50	309	54.3

The term close-out panel refers to the interior sections which are last to go in and first to come out. Because they are frequently removed, they require a quick installation fastener and these LORD isolators incorporate a convenient quarter-turn fastener.

INTERIOR ISOLATORS

ROD ENDS FOR TURNBUCKLES AND LUGGAGE BINS



- **Maximum rated load per mount:**
60 to 80 lb (27 to 36 kg)
- **Weight:**
0.26 to 0.50 oz (7.3 to 14.1 g)

- **Materials:**
Inner member – 7075-T651 aluminum alloy
Rod end – 7075-T6 aluminum alloy
Finish – chromate treated per MIL-DTL-5541, Class 1A
Elastomer – NR

TABLE 1 – PERFORMANCE CHARACTERISTICS

Part Number	Rated Load	Thread Dir	Static Spring Rate		Dynamic Springrate		Ultimate Load		Nat Freq	Weight
	lbs		lb/in	N/mm	lb/in	N/mm	lbs	Kg	Hz	
RA-75-3-1	60	RH	7000	1226	8560	1500	2500	1130	37	0.26
RA-75-3-2	60	LH	7000	1226	8560	1500	2500	1130	37	0.26
RA-80-9-1	70	RH	7000	1226	8560	1500	2800	1270	34.5	0.38
RA-80-9-2	70	LH	7000	1226	8560	1500	2800	1270	34.5	0.38
RA-90-10-1	80	RH	7000	1226	8560	1500	3600	1630	32	0.50
RA-90-10-2	80	LH	7000	1226	8560	1500	3600	1630	32	0.50

Elastomeric Rod ends are a very effective means to isolate turnbuckles and strut applications in the aircraft interiors. Luggage (stow) bins are the most common use, but monuments also benefit from their use.

FIGURE 1 – RA-75-3-X PART DIMENSIONS

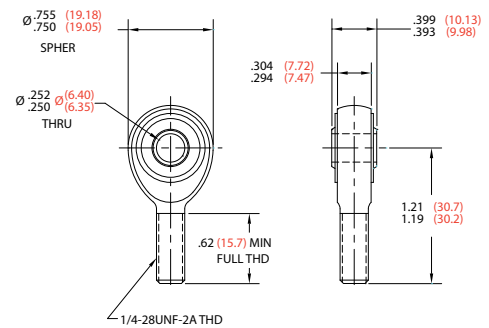

Metric values in parenthesis.

FIGURE 3 – RA-90-10-X PART DIMENSIONS

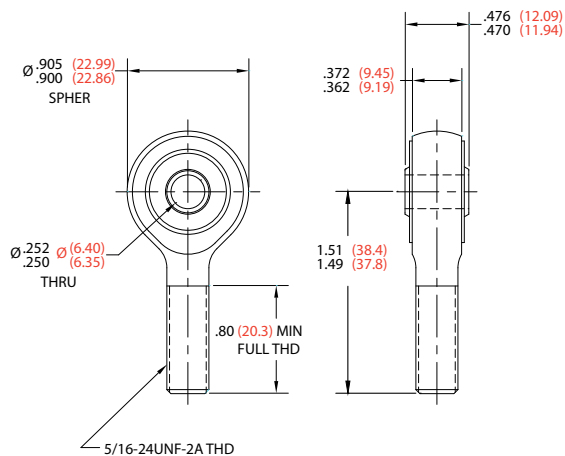
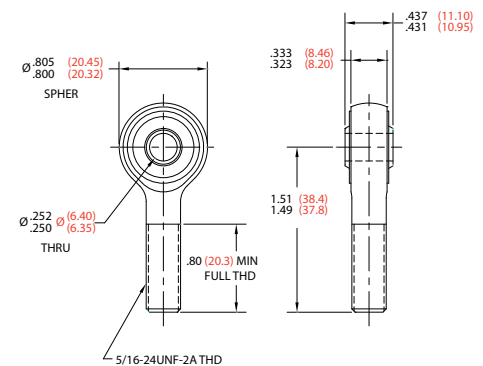

FIGURE 2 – RA-90-9-X PART DIMENSIONS



Metric values in parenthesis.

INTERIOR ISOLATORS

GROMMETS - FOR LIGHT STRUCTURE AND WINDOW REVEALS



- **Maximum rated load per mount:**
.25 to 3.5 lb (.11 to 1.6 kg)
- **Weight:**
.08 to .19 oz (2.27 to 5.39 g)

- **Materials:**
Elastomer – Silicone
Spacer (CB-1077-52) – Alloy steel, cadmium plated

FIGURE 2 – J-28132-1 PART DIMENSIONS

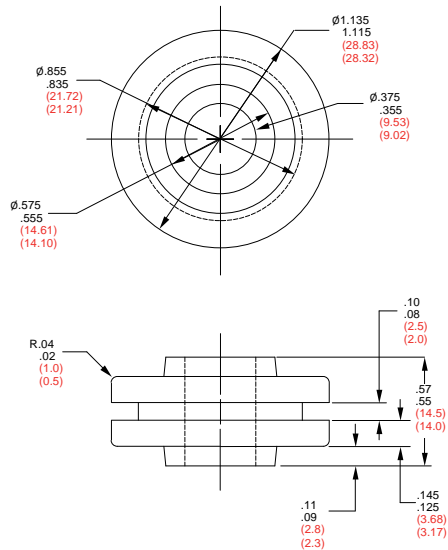

Metric values in parenthesis.

FIGURE 4 – CB-1077-52 PART DIMENSIONS

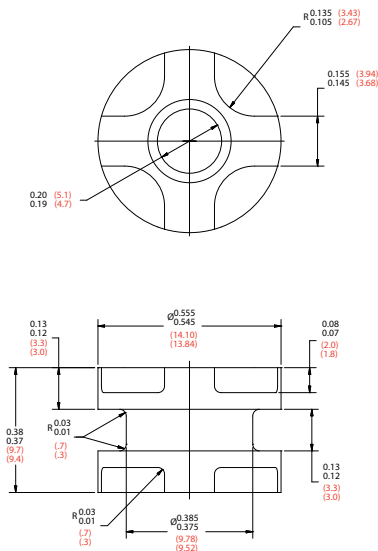

Metric values in parenthesis.

Elastomeric Grommets are an effective means to decoupling light weight panels and to avoiding a "short-circuit" in acoustic treatments. Wind reveals, door trim and bulkhead fascia are common uses.

FIGURE 1 – J-28132-1 INSTALLATION DRAWING

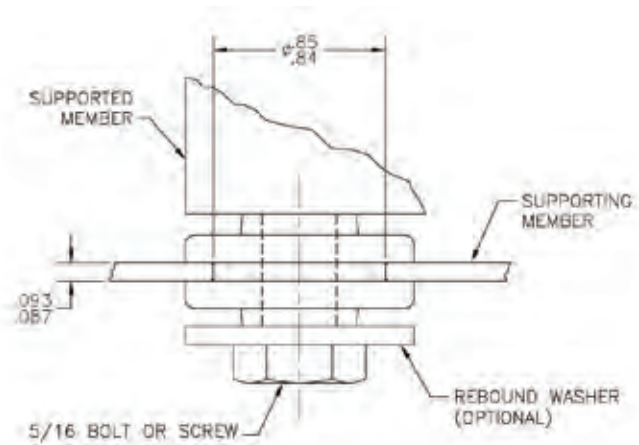
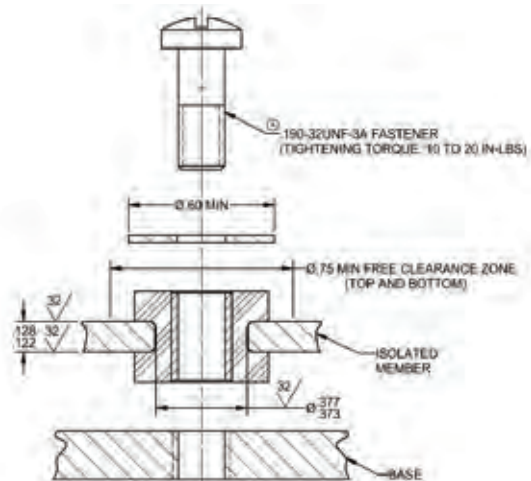

FIGURE 3 – CB-1077-52 INSTALLATION DRAWING



QUESTIONNAIRES

ENGINEERING DATA FOR VIBRATION AND SHOCK ISOLATOR QUESTIONNAIRE

Please fill in as much detail as possible before contacting LORD. You may fax or e-mail this completed form.

For technical assistance, contact: LORD Corporation; Application Engineering; 2000 West Grandview Blvd.; Erie, PA 16514; Phone: +1 877 ASK LORD (275 5673) in United States and Canada; Fax: +1 814 860 3871; E-mail: customer.support@lord.com

I. PHYSICAL DATA

- A. Equipment weight _____
- B. C.G. location relative to mounting points _____
- C. Sway space _____
- D. Maximum mounting size _____
- E. Equipment and support structure resonance frequencies _____
- F. Moment of inertia through C.G. for major axes (necessary for natural frequency and coupling calculations)
I xx _____ I yy _____ I zz _____
- G. Fail-safe installation required? Yes No

II. DYNAMICS DATA

- A. Vibration requirement:
 - 1. Sinusoidal inputs (specify sweep rate, duration and magnitude or application input specification curve) _____
 - 2. Random inputs (specify duration and magnitude (g^2/Hz) applicable input specification curve) _____
- B. Resonant dwell (input & duration) _____
- C. Shock requirement:
 - 1. Pulse shape _____ pulse period _____ amplitude _____
number of shocks per axis _____ maximum output _____
 - 2. Navy high impact required? (if yes, to what level?) _____
- D. Sustained acceleration: magnitude _____ direction _____
Superimposed with vibration? Yes No
- E. Vibration fragility envelope (maximum G vs. frequency preferred) or desired natural frequency and maximum transmissibility _____
- F. Maximum dynamic coupling angle _____
matched mount required? Yes No
- G. Desired returnability _____
Describe test procedure _____

III. ENVIRONMENTAL DATA

- A. Temperature: Operating _____ Non-operating _____
- B. Salt spray per MIL _____ Humidity per MIL _____
Sand and dust per MIL _____ Fungus resistance per MIL _____
Oil and/or gas _____ Fuels _____
- C. Special finishes on components _____

QUESTIONNAIRES

ENGINEERING DATA FOR VIBRATION AND SHOCK ISOLATOR QUESTIONNAIRE (CONT'D)

Sketch equipment outline and dimensions. Show preferred mount location and C.G. position. Attach available drawings showing interface details between mountings and equipment and support structure. Provide outline of preferred sway space available.



NOTES

Estimated prototype requirements (qty.) _____	Date _____
Date _____	Name _____
Qualification of mounts (qty.) _____	Title _____
Date _____	Company _____
Estimated production requirements (qty.) _____	Address _____
Delivery date _____	_____
Starting date _____	City _____
Remarks _____	State _____ Zip _____
_____	Telephone _____ Ext. _____
_____	E-mail _____
_____	Fax _____

QUESTIONNAIRES

SHIPPING CONTAINER SUSPENSION SYSTEM QUESTIONNAIRE

Please fill in as much detail as possible before contacting LORD. You may fax or e-mail this completed form.

For technical assistance, contact: LORD Corporation; Application Engineering; 2000 West Grandview Blvd.; Erie, PA 16514; Phone: +1 877 ASK LORD (275 5673) in United States and Canada; Fax: +1 814 860 3871; E-mail: customer.support@lord.com

Name _____ Date _____
Company name _____
Location _____
Telephone _____ Fax _____ E-mail _____

I. UNIT DATA

- A. Name and description _____
B. Suspended weight: _____ lb
C. Moment of inertia about C.G. (lb-in-sec²):
I_{xx} _____ I_{yy} _____ I_{zz} _____
D. Mount selection: See sketch See attached drawing

II. INPUT DATA

Shock

- A. Vertical flat drop height: _____ inches
B. Side impact velocity: _____ ft/sec
C. End impact velocity: _____ ft/sec
D. End rotational drop height: _____ inches; Block height _____ inches
(Container dimensions required - see Section VII.)
E. Other _____

Vibration

- A. Per specification _____
B. Test description _____

III. RESPONSE REQUIREMENTS

Shock

- A. Fragility: _____ g at C.G. and _____ g at other point(s) located at _____
B. Maximum sway: _____ in. at C.G. and _____ in. at other point(s) located at _____

Vibration

- A. Fragility: _____ g at C.G. and _____ g at other point(s) located at _____
B. Maximum motion: _____ in. D.A. at C.G. _____ in. D.A. at other point(s) located at _____

QUESTIONNAIRES

SHIPPING CONTAINER SUSPENSION SYSTEM QUESTIONNAIRE (CONT'D)

IV. ENVIRONMENT (*Temperature, storage, fungus, oil, etc.*)

V. MOUNT REQUIREMENTS (*Space envelope, markings, attachment, etc.*)

VI. DELIVERY REQUIREMENTS (*Prototype or production, number of units, due date*)

VII. SKETCH (*Show mount locations and orientations; include supplemental sketch if necessary for clarification.*)

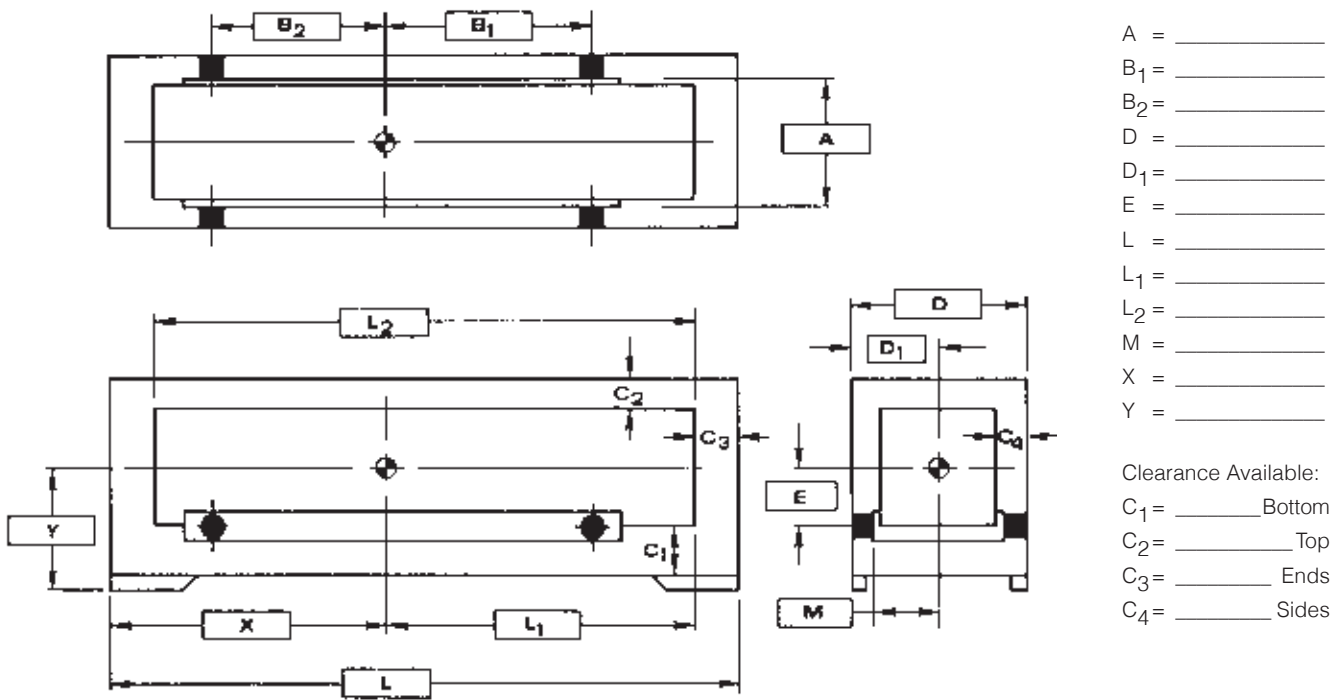

VIII. ADDITIONAL COMMENTS/INFORMATION

CUSTOM DESIGNED SOLUTIONS

CUSTOM-ENGINEERED SOLUTIONS

LORD offers more than 800 standard products to meet the requirements of most applications, but some control problems require specialized solutions such as a custom-designed mount or a combination of LORD products. LORD Corporation's vibration and noise control experts can analyze your individual requirements and provide the most effective and affordable product solutions.

REAL-WORLD TESTING

Our engineering and test laboratory gives our customers confidence that the solution designed for their application will perform as promised – use after use. The lab features more than 30,000 square feet of space with 30 major machines for static and dynamic testing. In this facility, our engineers routinely do fatigue testing on parts and systems under actual load conditions. Many of our customers have also used our facilities to evaluate new processes and materials and to test incoming material and prototype parts.

To access our custom-design capability, please call +1 877 ASK LORD (275 5673).

SYSTEMS INTEGRATION

Since many application problems caused by motion cannot be controlled by a single part, or set of parts, we provide our customers with total system solutions. Beginning with system design analysis, our engineers blend innovative ideas with unique materials to create optimized vibration, shock, motion and noise control systems.

WORLD CLASS PRODUCT DESIGN

Developing ways to minimize the effects of vibration, shock and motion is what our engineers do every day. Armed with more than 75 years of experience and state-of-the-art analysis equipment and software, we'll work with you to analyze your problem and develop a solution that will hold up under real-life conditions. Technical analysis, product design and materials testing are all performed in-house, providing you with quick turnaround and personal services – from design to prototype to the final product.



LORD Corporation does not hold a Parts Manufacturer Approval (PMA) for the articles listed below; therefore, they are NOT being produced as replacement or modification articles for installation on type-certificated products (ref. 14 CFR section 21.9). The list of such articles is as follows: 150APF-8, 150APLW-12, AM-001-2, AM-004-14, AM-005-11, AM-006-5, AM-006-7, AM-006-9, AM-007-1, AM-007-6, AM-007-14, AM-008-1, HT0-5, HT1-15, HT1-20, HT2-35, MCB005-1, MCB005-9, MGS001-W-3.

**A part's listing in this catalog does not guarantee its immediate availability.
To download / print the most current catalog, go to www.lord.com.**

Values stated herein represent typical values as not all tests are run on each lot of material produced. For formalized product specifications or specific product end uses, contact the Customer Support Center.

Information provided herein is based upon tests believed to be reliable. In as much as LORD Corporation has no control over the manner in which others may use this information, it does not guarantee the results to be obtained. In addition, LORD Corporation does not guarantee the performance of the product or the results obtained from the use of the product or this information where the product has been repackaged by any third party, including but not limited to any product end-user. Nor does the company make any express or implied warranty of merchantability or fitness for a particular purpose concerning the effects or results of such use.

No part of this publication may be reproduced, transmitted, transcribed, stored in a retrieval system or translated into any language in any form by any means without written permission of LORD Corporation.

BTR, SPE and "Ask Us How" are trademarks of LORD Corporation or one of its subsidiaries.

LORD provides valuable expertise in adhesives and coatings, vibration and motion control, and magnetically responsive technologies. Our people work in collaboration with our customers to help them increase the value of their products. Innovative and responsive in an ever-changing marketplace, we are focused on providing solutions for our customers worldwide ... Ask Us How.

LORD Corporation
World Headquarters

111 Lord Drive
Cary, NC 27511-7923
USA

Customer Support Center (in United States & Canada)

+1 877 ASK LORD (275 5673)

www.lord.com

For a listing of our worldwide locations, visit LORD.com.